

Line Thermal Printer

ESC/POS<sup>®</sup> Mode  
Command Specifications

Revision 2.52

Star Micronics Co., Ltd.  
Special Products Division

## Contents

1. INTERFACE CONFIGURATION	9
1-1 RS-232 Serial Interface	9
1-1-1 Specifications (Conforming to RS-232)	9
1-1-2 Switching Between Online and Offline	9
1-1-3 Signal Array and Explanations According to Interface Connector Pin	10
1-1-4 Timing for Transmitting XON/XOFF	11
1-1-5 Serial Interface Connection Example	11
1-1-6 Precautions When Switching the BUSY Conditions	12
1-1-7 Notes on resetting the printer using the interface	13
1-2 Bi-directional Parallel Interface (IEEE1284)	14
1-2-1 Compatibility Mode (Host – Printer Communications: Conforms to Centronix)	14
1-2-2 Reverse Mode (Printer to Host Communications)	14
1-2-3 Interface Connector Pin Arrangement for Each Mode	15
1-2-4 Data Reception Timing (Compatibility Mode)	16
1-2-5 Precautions When Resetting the Printer Using the Interface	17
1-2-6 Receiving Status from the Printer Using a Bidirectional Parallel Interface	17
1-3 USB Interface	18
1-4 Ethernet Interface	18
1-5 Wireless LAN Interface	18
1-6 Powered USB	18
1-7 Bluetooth Interface	18
2. EXPLANATION OF THE PAGE MODE	19
2-1 General Description	19
2-2 Settings Using Commands in Standard Mode and Page Mode	19
2-3 Expanding Print Data to the Print Region	20
3. COMMAND FUNCTION LIST	23
4. COMMAND DETAILS	30
4-1 Explanation of Terms	30
4-2 Exception Processing	32
4-3 Command Details	33
4-3-1 Standard Commands	33
HT	33
LF	34
FF	35
CR	36
CAN	37
DLE EOT n	38
DLE ENQ n	39
DLE DC4 n m t	40
ESC FF	41
ESC SP n	42
ESC ! n	43
ESC \$ nL nH	44
ESC % n	45
ESC& yc1c2 [x1d1...d (y x x1) ] ... [axd1...d (yxax)]	46
ESC * m nL nH d1...dk	49
ESC - n	51
ESC 2	52
ESC 3 n	53
ESC = n	54
ESC ? n	55
ESC @	56
ESC D n1 ... nk NUL	57
ESC E n	58

ESC G n	59
ESC J n	60
ESC L	61
ESC M n	62
ESC R n	63
ESC S	64
ESC T n	65
ESC V n	66
ESC W xL xH yL yH dxL dxH dyL dyH	67
ESC \ nL nH	69
ESC a n	70
ESC c 3 n	71
ESC c 4 n	72
ESC c 5 n	73
ESC d n	74
ESC p m t1 t2	75
ESC t n	76
ESC { n	77
FS g 1 m a1 a2 a3 a4 nL nH d1 ... dk	78
FS g 2 m a1 a2 a3 a4 nL nH	80
FS p n m	82
FS q n [xL xH yL yH d1...dk] 1... [xL xH yL yH d1...dk] n	83
GS ! n	86
GS \$ nL nH	88
GS * xy d1 ... d (xX yX 8)	89
<Function 49> GS ( K pL pH fn m (Fn=49)	92
<Function 50> GS ( K pL pH fn m (Fn=50)	94
GS ( L pL pH m fn [parameter]	95
GS 8 L p1 p2 p3 p4 m fn [parameter]	95
<Function 48> GS ( L pL pH m fn (fn=48)	96
<Function 48> GS 8 L p1 p2 p3 p4 m fn (fn=48)	96
<Function 51> GS ( L pL pH m fn (fn=51)	97
<Function 51> GS 8 L p1 p2 p3 p4 m fn (fn=51)	97
<Function 64> GS ( L pL pH m fn d1 d2 (fn=64)	98
<Function 64> GS 8 L p1 p2 p3 p4 m fn d1 d2 (fn=64)	98
<Function 65> GS ( L pL pH m fn d1 d2 d3 (fn=65)	99
<Function 65> GS 8 L p1 p2 p3 p4 m fn d1 d2 d3 (fn=65)	99
<Function 66> GS ( L pL pH m fn kc1 kc2 (fn=66)	100
<Function 66> GS 8 L p1 p2 p3 p4 m fn kc1 kc2 (fn=66)	100
<Function 67> GS ( L pL pH m fn a kc1 kc2 b xL xH y L yH [c d1 ... dk] 1 ... [c d1 ... dk] b (fn=67)	101
<Function 67> GS 8 L p1 p2 p3 p4 m fn a kc1 kc2 b xL xH y L yH [c d1 ... dk] 1 ... [c d1 ... dk] b (fn=67)	101
<Function 69> GS ( L pL pH m fn kc1 kc2 x y (fn=69)	103
<Function 69> GS 8 L p1 p2 p3 p4 m fn kc1 kc2 x y (fn=69)	103
<Function 112> GS ( L pL pH m fn a bx by c xL xH yL yH d1...dk (fn=112)	105
<Function 112> GS 8 L p1 p2 p3 p4 m fn a bx by c xL xH yL yH d1...dk (fn=112)	105
GS ( N pL pH n m	106
GS ( k pL pH cn fn [parameter]	107
<Function 065> GS ( k pL pH m cn n (cn=48, fn=65)	108
<Function 066> GS ( k pL pH m cn n (cn=48, fn=66)	109
<Function 067> GS ( k pL pH cn fn n (cn=48, fn=67)	110
<Function 068> GS ( k pL pH cn fn n (cn=48, fn=68)	110
<Function 069> GS ( k pL pH cn fn m n (cn=48, fn=69)	111
<Function 70> GS ( k pL pH cn fn m (cn=48, fn=70)	112
<Function 080> GS ( k pL pH cn fn m d1...dk (cn=48, fn=80)	112
<Function 081> GS ( k pL pH cn fn m (cn=48, fn=81)	113
<Function 082> GS ( k pL pH cn fn m (cn=48, fn=82)	114
<Function 165> GS ( k pL pH cn fn n1 n2 (cn=49, fn=65)	115
<Function 167> GS ( k pL pH cn fn n (cn=49, fn=67)	115
<Function 169> GS ( k pL pH cn fn m n (cn=49, fn=69)	116

<Function 180> GS ( k pL pH cn fn m n (cn=49, fn=80)	116
<Function 181> GS ( k pL pH cn fn m (cn=49, fn=81)	117
<Function 182> GS ( k pL pH cn fn m (cn=49, fn=82)	117
<Function 367> GS ( k pL pH cn fn n (cn=51, fn=67)	118
<Function 371> GS ( k pL pH cn fn nL nH (cn=51, fn=71)	118
<Function 380> GS ( k pL pH cn fn m n d1...dk (cn=51, fn=80)	119
<Function 381> GS ( k pL pH cn fn m (cn=51, fn=81)	120
<Function 467> GS ( k pL pH cn fn n (cn=52, fn=67)	121
<Function 471> GS ( k pL pH cn fn nL nH (cn=52, fn=71)	121
<Function 472> GS ( k pL pH cn fn n (cn=52, fn=72)	122
<Function 480> GS ( k pL pH cn fn m a b d1...dk (cn=52, fn=80)	123
<Function 481> GS ( k pL pH cn fn m (cn=52, fn=81)	125
GS / m	126
GS:	127
GS B n	128
GS C 0 n m	129
GS C 1 aL aH bL bH n r	130
GS C 2 nL nH	131
GS C ; sa; sb; sn; sr; sc;	132
GS E n	133
GS H n	134
GS I n	135
GS L nL nH	137
GS P x y	138
GS T n	140
GS V m	141
GS V m n	142
GS W nL nH	143
GS \ nL nH	144
GS ^ r t m	145
GS b n	146
GS c	147
GS f n	148
GS h n	149
1. GS k m d1 ... dk NUL,	150
2.3. GS k m n d1 ... dk	150
GS r n	157
GS v 0 m xL xH yL yH d1 ... dk	158
GS w n	160
<b>4-3-2 Chinese Character Control Commands</b>	<b>161</b>
FS ! n	161
FS &	162
FS - n	164
FS .	165
FS 2 c1 c2 d1 ... dk	166
FS C n	168
FS S n1 n2	169
FS W n	170
<b>4-3-3 ESC/POS Black Mark Commands</b>	<b>171</b>
FF	172
DLE ENQ n	173
GS FF	174
GS ( F pL pH a m nL nH	175
GS ( M pL pH n m (Function Code: n = 1, 49)	176
GS ( M pL pH n m (Function Code: n = 2, 50)	177
GS ( M pL pH n m (Function Code: n = 3, 51)	178
GS <	179
GS V m n	180
<b>4-3-4 STAR Original Commands</b>	<b>181</b>
ESC GS = nL nH da1 ... dak db1 ...dbk	181

ESC GS t n	182
ESC GS # m N n1 n2 n3 n4 LF NUL	184
ESC RS F n	186
ESC RS C n	187
ESC RS L m	188
ESC GS ETX s n1 n2	189
<b>4-3-5 STAR Original Presenter Control Commands</b>	<b>193</b>
ESC SYN 0 n	193
ESC SYN 1 n	194
ESC SYN 3 n	195
ESC SYN4 n	196
ESC GS SUB DC1 m t1 t2	197
ESC GS SUB DC2 m t1 t2	198
ESC GS SUB DC3 m t1 t2	199
<b>4-3-6 STAR Original Mark Commands</b>	<b>200</b>
ESC GS * 0 n m1 m2 m3 ... mk	201
ESC GS * 1 h v	202
ESC GS * 2 m c w	203
ESC GS * W	204
ESC GS * C	204
<b>4-3-7 STAR Original Auto Logo Commands</b>	<b>205</b>
ESC GS / W	208
ESC GS / C	209
ESC GS / 1 n	210
ESC GS / 2 n	211
ESC GS / 3 nL nH d1 d2 ... dk	212
ESC GS / 4 nL nH d1 d2 ... dk	213
ESC GS / 5 n	214
ESC GS / 6 n	215
<b>4-3-8 STAR Original Buzzer Commands</b>	<b>216</b>
ESC GS BEL m t1 t2	216
ESC GS EM DC1 m n1 n2	217
ESC GS EM DC2 m n1 n2	218
<b>4-3-9 Two-dimensional Bar Code 2D Code PDF417 Command Details</b>	<b>219</b>
ESC GS x S 0 n p1 p2	222
ESC GS x S 1 n	222
ESC GS x S 2 n	223
ESC GS x S 3 n	224
ESC GS x D nL nH d1 d2 ... dk	224
ESC GS x P	225
ESC GS x I	226
<b>4-3-10 STAR Original Print Starting Trigger Control Commands</b>	<b>227</b>
ESC GS g 0 m n	227
ESC GS g 1 m n	227
<b>4-3-11 STAR Original 2-Dimensional Bar Code QR Code Command Details</b>	<b>228</b>
ESC GS y S 0 n	230
ESC GS y S 1 n	230
ESC GS y S 2 n	230
ESC GS y D 1 m nL nH d1 d2 ... dk	231
ESC GS y D 2 a m1 n1L n1H d11 d12 ... d1k m2 n2L n2H d21 d22 ... d2k ml ... dlk	232
ESC GS y P	234
ESC GS y I	234
<b>4-3-12 STAR Original Page Function Commands</b>	<b>235</b>
ESC GS h 0 k m n	235
ESC GS h 1 k m n	236
<b>4-3-13 Star Original Reduced Printing Function Command</b>	<b>238</b>
ESC GS c h v	238
<b>4-3-14 STAR Original Text Search Commands</b>	<b>239</b>
ESC GS ) B pL pH fn [parameter]	239

<Function 48> ESC GS ) B pL pH fn m (fn = 48)	241
<Function 49> ESC GS ) B pL pH fn m (fn = 49)	242
<Function 50> ESC GS ) B pL pH fn m (fn = 50)	243
<Function 64> ESC GS ) B pL pH fn m k d1...dk (fn = 64)	244
<Function 65> ESC GS ) B pL pH fn m k1 k2 d1...dk (fn = 65)	245
<Function 66> ESC GS ) B pL pH fn n t (fn = 66)	246
<Function 80> ESC GS ) B pL pH fn m (fn = 80)	247
<Function 81> ESC GS ) B pL pH fn m (fn = 81)	248
<Function 96> ESC GS ) B pL pH fn m (fn = 96)	249
4-3-15 Star Original Printer Information Transmission Commands	250
ESC GS ) l pL pH fn [parameter]	250
<Function 48> ESC GS ) l pL pH fn d1 d2	251
4-3-16 Star Original Individual Logo Commands	252
ESC GS ) L pL pH fn [parameter]	252
<Function 48> ESC GS ) L pL pH fn kc1 kc2	253
<Function 49> ESC GS ) L pL pH fn kc1 kc2	255
<Function 50> E S C G S ) L p L p H f n d 1 d 2	256
ESC GS s O z a n c1 c2 d1 d2 t1 t2	257
ESC GS s P	258
ESC GS s R z n1 n2 n3 d1 ... dn	258
ESC GS s U z n [k1 k2 k3 d1 ... dk]1 ... [k1 k2 k3 d1 ... dk]n	261
ESC GS s T a t1 t2	263
ESC SYN DC3 n	264
ESC SYN DC4 n	265
ESC GS ) s pL pH fn m (fn = 48)	266
5. CHARACTER CODE TABLE	263
6. APPENDIX	264
6-1 Appendix 1 Cautions	264
6-2 Appendix 2 Status Specifications	265
6-2-1 Identifying Transmission Status	265
6-2-2 Error Details Per Model	265
6-2-3 DLE EOT Status	266
6-2-4 ASB Status Specifications	269
6-2-5 Printer Status Transmission Specification When Using Ethernet and Wireless I/F	272
6-3 Appendix-3 Blank Page Configuration	275
6-4 Appendix 4 Standard Mode	277
6-4-1 Printing Region	277
6-4-2 Left Margin	280
6-5 Appendix 5 Page Mode	283
6-5-1 Page Mode Print Region	283
6-5-2 Usage Example of Page Mode	290
6-6 Appendix 6 CODE 128 Bar Codes, GS-1 Bar Codes	292
6-6-1 General Description of CODE 128 Bar Codes	292
6-6-2 General Description of GS-1 Bar Codes	296
6-6-3 GS1 Databar Omnidirectional	299
6-6-4 GS1 Databar Truncated	299
6-6-5 GS1 Databar Limited	299
6-6-6 GS1 Databar Expanded	299
6-7 Appendix 7 Maximum Number of Input Characters for Each Version of QR Code	300
6-8 Appendix 8	304
Explanation of Print Startup Control Starting Printing When Set to Page Units	304
6-9 Appendix 9	305
Explanation of Printing NV bit image data defined by	305
“GS ( L <fn=67>” or “GS ( 8 <fn=67>”, by “FS p” command	305
6-10 Appendix 10 Special Specifications when the Bluetooth Interface (IFBD-HB03) is used	

	306
7. APPENDIX COMMAND LIST BY MODEL	306
7-1 RS-232C Interface	306
7-2 Parallel Interface	315
7-3 USB I/F (Ver 1.0) • Ethernet I/F (Silex 1.0)	324
7-4 USB I/F (Ver 2.0)	331
7-5 Powered USB I/F	340
7-6 Ethernet I/F	347
7-7 Wireless LAN I/F	355
7-8 Bluetooth I/F	363

This document is the ESC/POS® mode command specification manual .  
Information contained herein applies to models with the following conditions.

- Line Thermal Printers
  - Printer head: 203DPI
  - Interface: Parallel, RS-232C, USB, Ethernet, Wireless LAN, Powered USB  
Bluetooth
  - Printing Width: 3 inch and 4 inch
- < Applicable Models >
- 3 inch printers: TSP700 TSP600 TSP1000 TSP700II, TSP650, TUP500, FVP10,  
BSC-10, TSP043, TSP650II, TSP650IISK
  - 4 inch printers: TSP800, TUP900, TSP800II



## 1. INTERFACE CONFIGURATION

### 1-1 RS-232 Serial Interface

#### 1-1-1 Specifications (Conforming to RS-232)

Data transmission method	Serial
Synch method	Start-Stop synchronization method
Handshake	DTR/DSR/XON/XOFF
Signal level	MARK = -3v to -15v Logic '1'/OFF SPACEK = +3v to +15v Logic '0'/ON
Baud rates	2400, 4800, 9600, 19200, 38400, 57,600, 115,200 bps
Bit length	7, 8 bits
Parity	None, odd, even
Stop bit:	1 bit (Fixed)
Connector	D-SUB 25 (Male)/D-SUB 9 (Male)

Note: Handshake, bit length, baud rates and parity settings are set by the DIP switches or the memory switches.

#### 1-1-2 Switching Between Online and Offline

This printer does not have a switch to go between online and offline. The following conditions are required to go offline.

- The time after initializing the mechanism when turning on the power or causing a reset by the interface until communication is possible
- When executing a self-test • When the cover is open
- When printing has stopped because there is no paper  
(When the roll paper end sensor detects that paper is out, or the roll paper near end sensor detects that paper is out using ESCc4, or paper is out when the print stop is enabled.)
- When waiting to switch at macro execution
- While there is a temporary error in the power voltage
- When there is an error

### 1-1-3 Signal Array and Explanations According to Interface Connector Pin

<Signal Array and Functions>

Pin No.	Signal Name	Signal Dir.	Function																																
1	FG	-	Frame ground																																
2	TXD	Output	Transmission Data																																
3	RXD	Input	Reception Data																																
4	RTS	Output	Same as DTR signal																																
6	DSR	Input	Signal indicating whether host can receive data. The SPACE status indicates the host can receive data; the MARK status indicates that the host cannot receive data. When DTR/DSR control is selected, the status of this signal is checked to transmit data. (Excludes data transmissions using DLEEOT.) When XON/XOFF control is selected, the status of this signal is not checked. This signal can be used to reset the printer according by switching the DIP switches or the memory switches.																																
7	SG	-	Signal ground																																
20	DTR	Output	<p>(1) When DTR/DSR control is selected: Indicates whether the printer is BUSY. The SPACE status indicates the printer is READY; the MARK status indicates that the printer is BUSY. The DIP switch or the memory switch settings change the conditions for the printer to be BUSY. (*1) The following conditions are required to enter a <u>BUSY (MARK)</u> state.</p> <table border="1" style="width: 100%; border-collapse: collapse;"> <thead> <tr> <th colspan="2" rowspan="2">Printer Status</th> <th colspan="2">Busy condition (*1)</th> </tr> <tr> <th>OFF</th> <th>ON</th> </tr> </thead> <tbody> <tr> <td rowspan="7" style="text-align: center; vertical-align: middle;">OFFLINE</td> <td>• During the period from when the power is turned on (including resetting using the interface) to when the printer is ready to receive data.</td> <td>BUSY</td> <td>BUSY</td> </tr> <tr> <td>• When executing a self-test</td> <td>BUSY</td> <td>BUSY</td> </tr> <tr> <td>• When the cover is open</td> <td>-</td> <td>BUSY</td> </tr> <tr> <td>• When printing stopped because of paper out</td> <td>-</td> <td>BUSY</td> </tr> <tr> <td>• When waiting to switch at macro execution</td> <td>-</td> <td>BUSY</td> </tr> <tr> <td>• While there is a temporary error in the power</td> <td>-</td> <td>BUSY</td> </tr> <tr> <td>• When there is an error</td> <td>-</td> <td>BUSY</td> </tr> <tr> <td></td> <td>• When reception buffer is full (*2) BUSY</td> <td>BUSY</td> <td>BUSY</td> </tr> </tbody> </table> <p>(2) XON/XOFF control is selected: Indicates whether the printer is connected normally and is ready to receive data from the host. A SPACE status indicate that the printer is connected normally and that data can be received. The SPACE status is always entered except for the following cases. • The time after initializing the mechanism when turning on the power until communication is possible. • While executing a self-test</p>	Printer Status		Busy condition (*1)		OFF	ON	OFFLINE	• During the period from when the power is turned on (including resetting using the interface) to when the printer is ready to receive data.	BUSY	BUSY	• When executing a self-test	BUSY	BUSY	• When the cover is open	-	BUSY	• When printing stopped because of paper out	-	BUSY	• When waiting to switch at macro execution	-	BUSY	• While there is a temporary error in the power	-	BUSY	• When there is an error	-	BUSY		• When reception buffer is full (*2) BUSY	BUSY	BUSY
Printer Status		Busy condition (*1)																																	
		OFF	ON																																
OFFLINE	• During the period from when the power is turned on (including resetting using the interface) to when the printer is ready to receive data.	BUSY	BUSY																																
	• When executing a self-test	BUSY	BUSY																																
	• When the cover is open	-	BUSY																																
	• When printing stopped because of paper out	-	BUSY																																
	• When waiting to switch at macro execution	-	BUSY																																
	• While there is a temporary error in the power	-	BUSY																																
	• When there is an error	-	BUSY																																
	• When reception buffer is full (*2) BUSY	BUSY	BUSY																																
25	INIT	Input	This signal can be used to reset the printer according by switching the DIP switches or the memory switches.																																

(\*1) DIPSW Settings: Conditions for BUSY

ON = Reception buffer full or printer is offline (Default)

OFF = Reception buffer full

(\*2) When the reception buffer empty region is 0 bytes, received data is ignored.

### 1-1-4 Timing for Transmitting XON/XOFF

When XON/XOFF control is selected, XON and XOFF are transmitted with the following timings. The transmission timing varies according to the DIP switch settings or the memory switch settings.

XON code: <11> H

XOFF code: <13> H

For (3) below, XON is not transmitted when the reception buffer is full.

For (6) below, XOFF is not transmitted when the reception buffer is full.

#### <XON/XOFF Transmission Timing>

	Printer Status	Busy condition (*1)	
		OFF	ON
XON Transmission	(1) When online for the first time after turning the power on or a reset using the interface	Transmission	Transmission
	(2) When the buffer full status was cancelled for reception buffer	Transmission	Transmission
	(3) When shifting from offline to online	-	Transmission
	(4) When recovered from a recoverable error using a command	-	Transmission
XOFF Transmission	(5) When the reception buffer entered buffer full status	Transmission	Transmission
	(6) When shifting from online to offline	-	Transmission

(\*1) DIPSW Settings: Conditions for BUSY

ON = Reception buffer full or printer is offline (Default)

OFF = Reception buffer full

### 1-1-5 Serial Interface Connection Example

- If the other connected party is DCE, be careful so that there is no status without a handshake (where data is flows) (DTE: Data Terminal Equipment; DCE: Data Circuit Terminating Equipment)
- When transmitting data to the printer, turn on the power to the printer and initialize first.

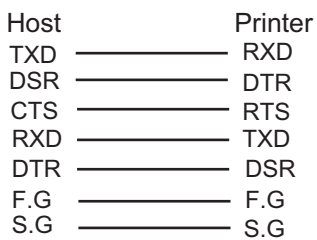

## 1-1-6 Precautions When Switching the BUSY Conditions

DIPSW Settings: Conditions for BUSY

ON = Reception buffer full or printer is offline (Default)

OFF = Reception buffer full

To set the busy conditions to reception buffer full (OFF), operators should be aware of the following points.

- Printing will stop but the printer will not enter a BUSY state when printing stops because of an error, the cover is open, paper is out when printing stops are enabled, or when paper feeds are executed using the paper feed switch.
- When using DLE EOT, DLE ENQ and DLE DC4, the reception buffer does not enter a buffer full status.
- Precautions on the host which cannot receive data transmissions when the printer is BUSY DLEEOT, DLEENQ and DLEDC4 cannot be used when an error occurs when the printer has entered a BUSY state because the reception buffer is full.
- Precautions on the host which can receive data transmissions when the printer is BUSY DLEEOT, DLEENQ and DLEDC4 are handled as bit image data when using the DLEEOT, DLEENQ and DLEDC4 partway through the bit image data when the reception buffer is full when transmitting bit image data. Also, it is possible to lose data when received while the reception buffer is full.

### 1-1-7 Notes on resetting the printer using the interface

The printer can be reset using interface pins 6 and 25 by changing the DIP switch or the memory switch setting. But when a signal that does not satisfy the requirements above is input, printer operation is not guaranteed.

Minimum reset pulse width: TRS 1 ms (minimum)

When using pin 6 (DSR)

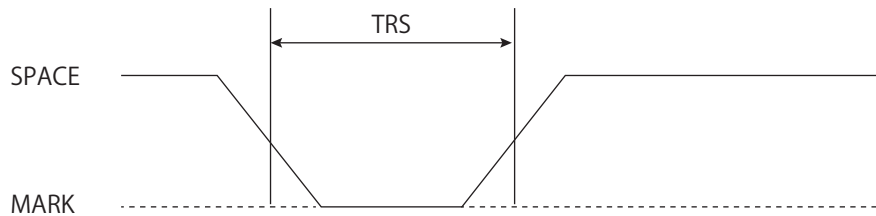

When using pin 25 (INIT)

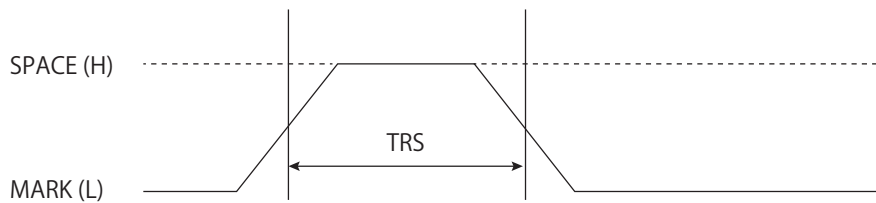

## 1-2 Bi-directional Parallel Interface (IEEE1284)

### 1-2-1 Compatibility Mode (Host – Printer Communications: Conforms to Centronix)

#### 1. General Description

The Compatibility Mode is a mode that uses the Centronix interface as standard, which is widely in use.

#### 2. Specifications

Data transmission method:	8 Bit Parallel
Synch method:	According to externally supplied nStrobe signal
Handshake:	According nAck signals and Busy signals
Signal level:	All signals are TTL compatible

#### 3. Switching Between Online and Offline

This printer does not have a switch to go between online and offline. The following conditions are required to go offline.

- The time after initializing the mechanism when turning on the power or causing a reset by the interface until communication is possible
- When executing a self-test
- When the cover is open
- When the paper is out and printing has stopped (paper out selected by ESCc4)
- When waiting to switch at macro execution
- When errors occur

### 1-2-2 Reverse Mode (Printer to Host Communications)

Status data transfer from the printer to the host is performed in either Nibble or Byte Mode.

#### General Description

Data transmissions from asynch printers controlled by the host are regulated. Nibble Mode data transmissions use an existing control line to transmit data 4 bits (Nibble) at a time. The Byte Mode uses bidirectional communications to transfer 8 bits of data lines. In either case, communications are in half-duplex because it is not possible to execute both simultaneously with the Compatibility Mode.

### 1-2-3 Interface Connector Pin Arrangement for Each Mode

Pin	Source	Compatibility Mode	Nibble Mode	Byte Mode
1	Host	nStrobe	HostClk	HostClk
2	Host/Ptr	Data0 (LSB)	Data0 (LSB)	Data0 (LSB)
3	Host/Ptr	Data1	Data1	Data1
4	Host/Ptr	Data2	Data2	Data2
5	Host/Ptr	Data3	Data3	Data3
6	Host/Ptr	Data4	Data4	Data4
7	Host/Ptr	Data5	Data5	Data5
8	Host/Ptr	Data6	Data6	Data6
9	Host/Ptr	Data7 (MSB)	Data7 (MSB)	Data7 (MSB)
10	Printer	nAck	PtrClk	PtrClk
11	Printer	Busy	PtrBusy/Data3,7	PtrBusy
12	Printer	PError	AckDataReq/Data2,6	AckDataReq
13	Printer	Select	Xflag/Data1,5	Xflag
14	Host	NC	HostBusy	HostBusy
15		NC	ND	ND
16		Signal GND	Signal GND	Signal GND
17		Frame GND	Frame GND	Frame GND
18	Printer	+5 V	+5 V	+5 V
19 to 30		Twisted Pair Return	Twisted Pair Return	Twisted Pair Return
31	Host	nInit	nInit	nInit
32	Printer	nFault	nDataAvail/Data0,4	nDataAvail
33		EXTGND	ND	ND
34	Printer	NC	ND	ND
35	Printer	NC	ND	ND
36	Host	nSelectIn	1284-Active	1284-Active

NC: Not Connected

ND: Not Defined

#### <Note>

- Initial 'n' of signal name indicates an 'L' active signal  
Bidirectional communications are not possible on hosts with even one of the above signal lines.
- Always use twisted pair lines for each signal line when using the interface and connect the return side to the signal ground level.
- All interface conditions use TTL levels as standard and must satisfy the following characteristics. Each signal rise and fall times must be a maximum of 0.5  $\mu$ s.
- Data transmissions for which nAck signals or Busy signals are ignored are prohibited. When ignored, data can be lost.
- Use the shortest distance necessary for the interface cable.

### 1-2-4 Data Reception Timing (Compatibility Mode)

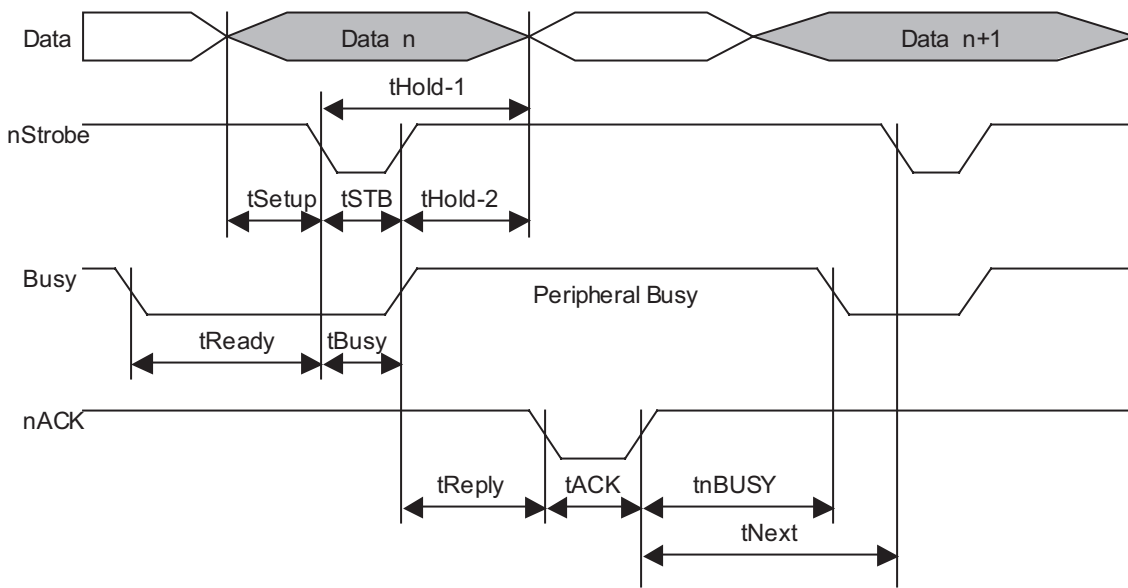

		Standards	
		Minimum [ns]	Maximum [ns]
Data Hold Time (host)	tHold-1	-	500
Data Hold Time (printer)	tHold-2	-	-
Data Setup Time	tSetup	-	500
STROBE Pulse Width	tSTB	-	500
READY Cycle Idle Time	tReady	-	-
BUSY Output Delay Time	tBUSY	0	500
Data Processing Time	tReply	0	$\infty$
ACKNLG Pulse Width	tACK	1usec/9usec (*1)	-
BUSY Cancel Time	tnBUSY	0	$\infty$
ACK Cycle Idle Time	tNext	-	0

(\*1) Memory Switch Setting: ACK Pulse Width

ON = 9usec

OFF = 1usec (Default)



### 1-2-5 Precautions When Resetting the Printer Using the Interface

When applying a printer reset using the interface (#31 pin nInit signal) in the Compatibility Mode, the following characteristics must be met. However, the printer reset is ignored when the signal nSelectIn (pin #36, 1284-Active HIGH) is active in reverse mode.

Reset Minimum Pulse Width	TRS	50 $\mu$ sec (min)
Rise Time	tf	500nsec (max)
Fall Time	tr	500nsec (max)

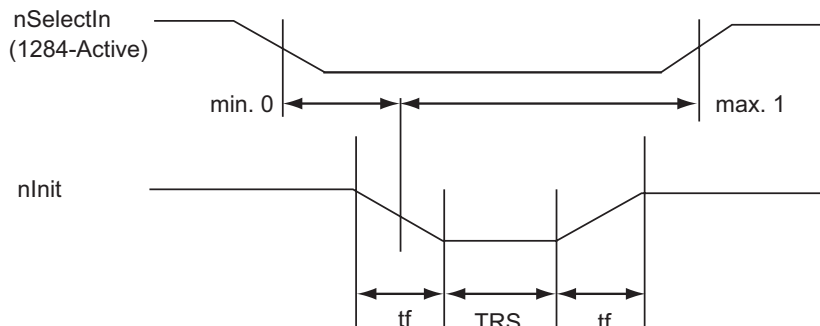

### 1-2-6 Receiving Status from the Printer Using a Bidirectional Parallel Interface

It is possible to transmit the status from the printer using bidirectional communications functions according to the Nibble and Byte Mode which conform to IEEE1284 standards, when using a bidirectional parallel interface. When doing so, compared to RS-232 serial interface specifications, you must pay attention to the following points because the printer cannot insert real-time interrupts to the host.

- The transmission buffer size in the printer is 128 bytes. (Excluding ASB status) Because statuses that exceed this are discarded, create a receive status (Reverse Mode) on the host side so that status are not lost.
- When using ASB, it is preferred that the host side be in a receive waiting status (a reverse idle status). If that is not possible, put the host side into a Reverse Mode to constantly monitor the presence of data.
- When using ASB, ASB status is transmitted with priority over other statuses in the Reverse Mode. Also, ASB status that are accumulated without being sent from the last sent ASB status to the latest ASB status are bundled into one ASB status and transmitted, and the latest ASB status is then transmitted after that.

Example: The following shows an ASB status in a normal (idled) state.

First Status		Second Status		Third Status		Fourth Status	
0000	1000	0000	0000	0000	0000	0000	0000

The following data is accumulated when a near end detection occurs, the cover is open and cover close is performed.

	First Status		Second Status		Third Status		Fourth Status		
1	0000	1000	0000	0000	0000	0011	0000	0000	Near End Detection
2	0010	1000	0000	0000	0000	0011	0000	0000	Cover Open
3	0000	1000	0000	0000	0000	0011	0000	0000	Cover Closed

Then, when the ASB status is received, the combination of actually transferred ASB is a total of 8 bytes: ASB (1 + 2 + 3) + the latest ASB (3).

ASB (1 + 2 + 3)		First Status		Second Status		Third Status		Fourth Status	
		0010	1000	0000	0000	0000	0011	0000	0000
+									
Latest ASB (3)		First Status		Second Status		Third Status		Fourth Status	
		0001	1000	0000	0000	0000	0011	0000	0000

### **1-3 USB Interface**

Specifications Conforms to USB 2.0 Full Speed  
Supports printer class and header class (Refer to each printer specifications manual to select.)  
Connector Type B

### **1-4 Ethernet Interface**

Specifications Conforms to IEEE 802.3  
Cable 10BASE-T/10BASE-TX  
Connector RJ45

### **1-5 Wireless LAN Interface**

Specifications Conforms to IEEE 802.11b

### **1-6 Powered USB**

Specifications See the Product Specifications Manual IFBD-BPU03  
Cable See the Product Specifications Manual IFBD-BPU03  
Connector See the Product Specifications Manual IFBD-BPU03

### **1-7 Bluetooth Interface**

Specifications: See the section "Bluetooth Interface model" in the separate "Product Specifications TSP650II".

## 2 EXPLANATION OF THE PAGE MODE

### 2-1 General Description

This printer has two print modes:

The Standard Mode and the Page Mode.

In the standard mode, the printer prints or performs a paper feed whenever it receives printing or paper feed instructions. With the Page mode, received printing or paper feed instructions are all performed on the print region in the specified memory, but the printer does not act. Then, when the ESCFF or FF command is executed, the data is expanded to that print region to print it in batch. Specifically, when printing or line feeding data of "ABCDEF" <LF>, the status mode prints "ABCDEF" and executes one line feed. However, with the page mode, "ABCDEF" is written to the specified print region on the memory and one line is moved in the memory position to write the next print data. The printer enters the page mode using ESCL. Subsequently received commands are all processed using the page mode. By executing ESCFF, data that is received is printed in batch. By executing FF, data that is received is printed in batch, then the printer recovers to the standard mode. It is possible to return to the standard mode without printing print data in the page mode using ESCS. However, that print data is cleared.

<Transition of Stand Mode Page Mode>

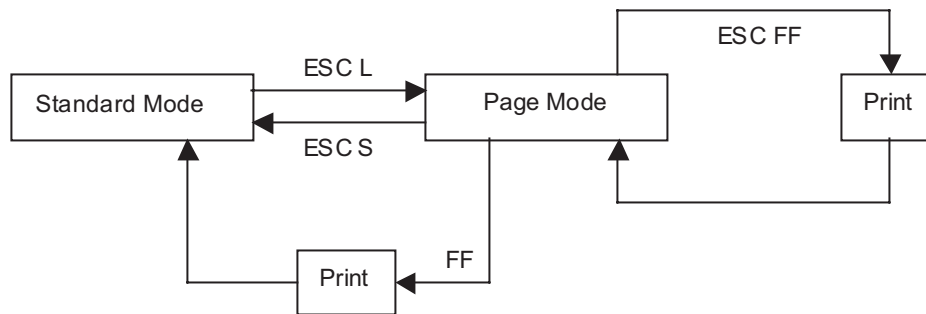

### 2-2 Settings Using Commands in Standard Mode and Page Mode

- The values set using each command are common settings for both the standard mode and the page mode, but the settings of the following commands are set independently for each. → ESCSP,ESC2,ESC3,FSS
- In the standard mode, the maximum number of dots are set for the X direction, but in the page mode, the Y direction (the X direction when not rotated) when rotated in either the 90 degree direction or the 270 degree direction becomes larger. For details see the print region setting command (ESCW) for the page mode.

## 2-3 Expanding Print Data to the Print Region

The following are performed when expanding print data to the print region.

- (1) The print region is set by ESCW, ESCW sets the left side as the print region origin (X0, y0) at the point all operations for previous printings and paper feeds are completed received by the printer. The square shape formed by the two sides of the dx pitch in the X direction (horizontal direction) including the origin and the dy pitch in the Y direction (vertical direction) from the origin (x0, y0) is the print region (When ESCW is not set, the initial value is the print region).
- (2) If the print region is set by ESCW and print direction is set by ESCT, the point A in the figure 2.3.1 is the initial value and print data expands to the print region when the printer receives the print data. In the case of characters, this starting point is the base line. Download bit images and bar codes are expanded for the top of the base line using the lower left point of the image data as the base line (Fig. 2.3.2 Point B) However, the HRI characters that come below the bar codes are printed below the base line. When trying to expand characters that are taller than standard characters (double-tall characters) or download bit images, the portion that is beyond the height of standard characters is not printed.
- (3) If print data is outside of the print region (including the space right of the character) before receiving the commands (LF, ESCJ, etc.) accompanying a line feed, a line feed is automatically performed in the print region and the expanding position of the print data is moved one line and the next expansion position becomes the head of the line. The line feed amount is the line feed amount set by ESC2 and ESC3.
- (4) The initial value of the line feed amount when using basic calculated pitch correction of 180 DPI is 4.23 mm (1/6 inch). This is equivalent to 33 dots. Therefore, when using expanded characters that are beyond the double-tall size in the vertical direction in the next line of print data, download bit images that are larger than two lines or bar codes that are taller than characters, the line amount will be insufficient and the upper dots of the characters in the next print data will overlap, so the amount of line feed must be increased. The line feed amount of the first line in the example below must be more than 28 dots (Fig. 3.12.4).

<Ex.> When printing a download bit image for 6 bytes in the vertical direction:

(Vertical dot count (8 x 6) – Starting line feed amount (20)) x Basic calculated pitch conversion in the vertical direction (360/180) = 56

Therefore, the line feed must be 56 pitches (28 dots) in excess.

ESCW, xL, xH, yL, yH, dxL, dxH, dyL, dyH

ESCTn

ESC354 ← Additional line feed amount

LF

GS/1

ESC2 ← Returns to a line feed amount of 4.23 mm (1/6 inch)

Note: The basic calculated pitch is 1/180 horizontally and 1/360 vertically with default, so a difference is generated with the position specification according to the print direction. By setting the basic calculated pitch in the vertical direction to 1/180 using a command (GSP), a difference will not be generated by print direction.

STAR The page print region setting, print data expansion position, line feed, position movement amount in the page mode are affected by the basic calculated pitch correction.

For details, see the command details for GSP (basic calculated pitch specification) and ESCW (print region setting command).

Fig. 2.3.1 Character Data Expansion Position

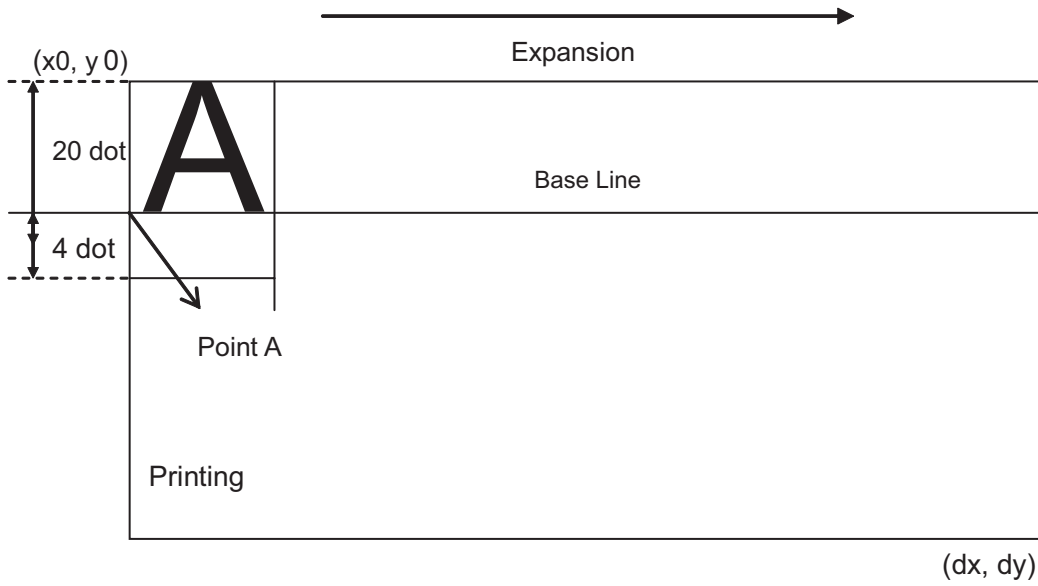

Fig. 2.3.2 Character Data Expansion Position

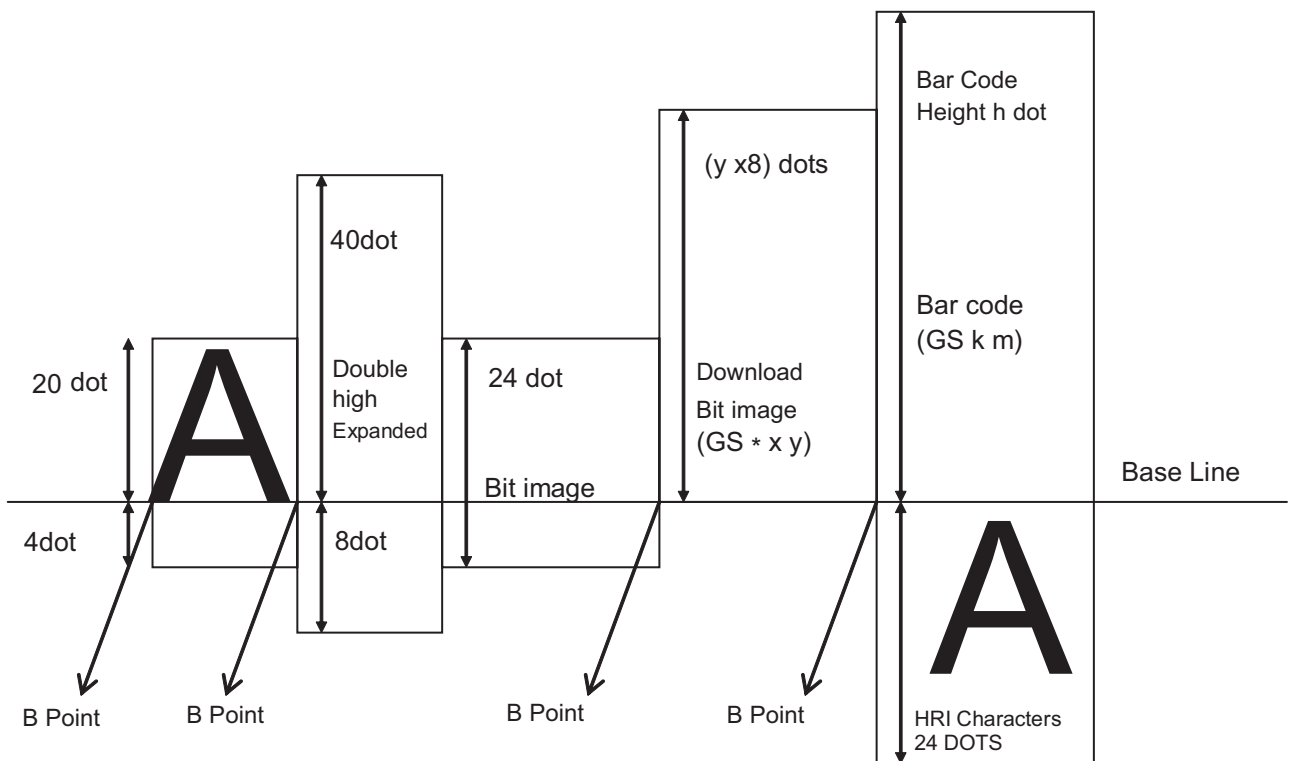
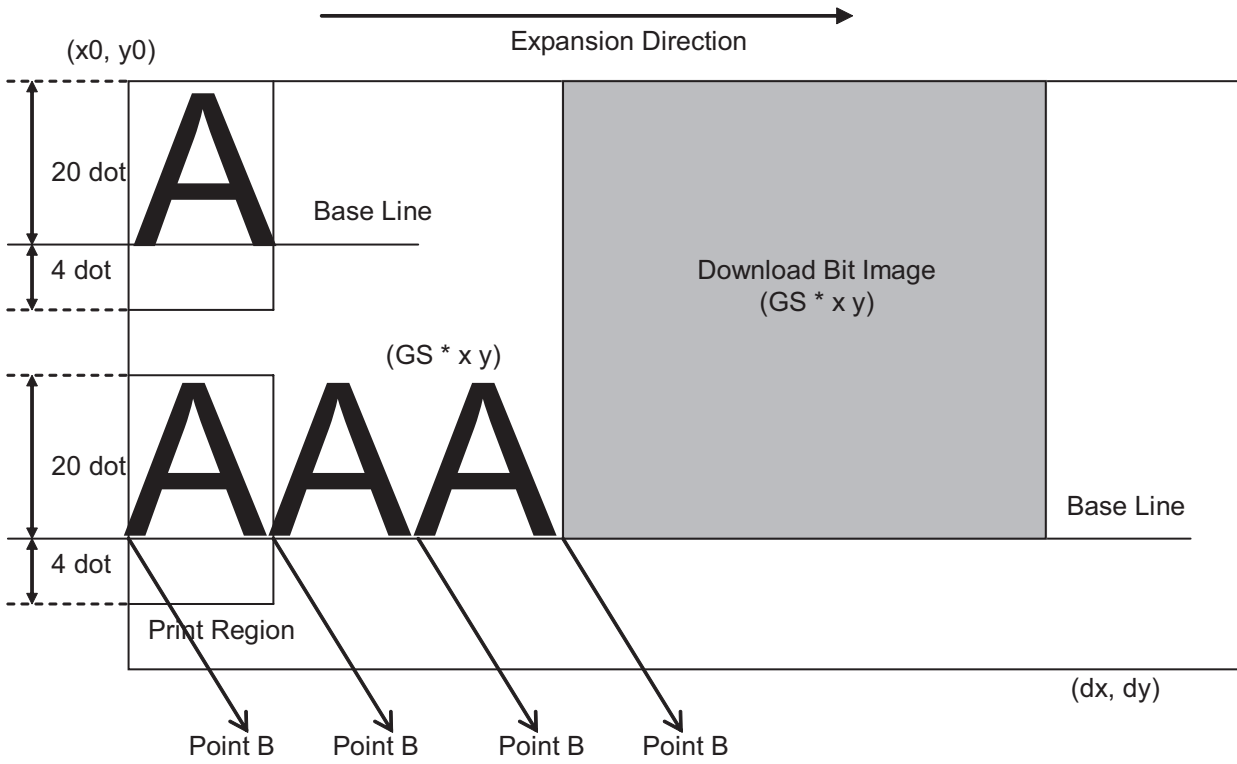

Fig. 2.3.3 Download Bit Image Expansion Position



### 3. COMMAND FUNCTION LIST

- : Valid
- (L): Effective only at the top of the line
- (S): Only setting effective
- (D): Effective only when there is no data in print buffer

#### Standard Commands

Commands	Name	Command Class		Std Mode	Page Mode	GS P Effect
		Exe.	Set			
HT	Horizontal tab	○		○	○	
LF	Line feed	○		○	○	
FF	Print and recover to page mode	○		Ignored	○	
CR	Print and carriage return	○		○	○	
CAN	Cancel print data in page mode	○		Ignored	○	
DLE EOT	Real-time status transmission	○		○	○	
DLE ENQ	Real-time request to printer	○		○	○	
DLE DC4	Real-time output of specified pulse	○		○	○	
ESC FF	Print data in page mode	○		Ignored	○	
ESC SP	Set character right space amount		○	○	○	○
ESC !	Batch specify print mode		○	○	○	
ESC \$	Specify absolute position	○		○	○	○
ESC %	Specify/cancel download character set		○	○	○	
ESC &	Define download characters		○	○	○	
ESC *	Specify bit image mode	○		○	○	
ESC -	Specify/cancels underline mode		○	○	○	
ESC 2	Set default line spacing		○	○	○	
ESC 3	Set line feed amount		○	○	○	○
ESC =	Select peripheral device		○	○	○	
ESC ?	Delete download characters		○	○	○	
ESC @	Initialize printer	○	○	○	○	
ESC D	Set horizontal tab position		○	○	○	
ESC E	Specify/cancel emphasized printing		○	○	○	
ESC G	Specify/cancel double printing		○	○	○	
ESC J	Print and Paper Feed	○		○	○	○
ESC L	Select page mode	○		(L)	Ignored	
ESC M	Select character font			○	○	
ESC R	Select international characters		○	○	○	
ESC S	Select standard mode	○		Ignored	○	
ESC T	Select character print direction in page mode		○	(S)	○	
ESC V	Specify/cancel char. 90 deg. clockwise rotation		○	○	(S)	
ESC W	Set print region in page mode		○	(S)	○	○
ESC \	Specify relative position	○		○	○	○
ESC a	Position alignment		○	(L)	(S)	
ESC c 3	Select paper out sensor to enable at paper out signal output		○	○	○	
ESC c 4	Select paper out sensor to enable at printing stop		○	○	○	
ESC c 5	Enable/disable panel switches		○	○	○	
ESC d	Print and feed paper n lines	○		○	○	
ESC p	Specify pulse	○		○	○	
ESC t	Select character code table		○	○	○	
ESC {	Specify/cancel upside-down characters		○	(L)	(S)	
FS g 1	Write data to user NV memory		○	○	Invalid	
FS g 2	Read user NV memory data	○		○	○	

Commands	Name	Command Class		Std Mode	Page Mode	GS P Effect
		Exe.	Set.			
FS p	Print NV bit image	○		○	Invalid	
FS q	Define NV bit image		○	(L)	Invalid	
GS !	Select character size		○	○	○	
GS \$	Specify absolute position for character vertical direction in page mode	○		Ignored	○	○
GS *	Define download bit images		○	○	○	
GS ( A	Test print	○		○	Ignored	
GS ( K (fn=48)	Set print density		○	○	○	
GS ( K (fn=49)	Set print speed		○	○	○	
GS ( L	Specify raster graphics data	○		○	Ignored	
GS 8 L	Specify raster graphics daa	○		○	Ignored	
GS ( N	Select 2 color printing		○	○	○	
GS ( k (cn=48, fn=65)	PDF417: Set number of positions		○	○	○	
GS ( k (cn=48, fn=66)	PDF417: Set number of levels		○	○	○	
GS ( k (cn=48, fn=67)	PDF417: Set module width		○	○	○	
GS ( k (cn=48, fn=68)	PDF417: Set level height		○	○	○	
GS ( k (cn=48, fn=69)	PDF417: Set error correction level		○	○	○	
GS ( k (cn=48, fn=70)	PDF417: Set options		○	○	○	
GS ( k (cn=48, fn=80)	PDF417: Store data in symbol saving region		○	○	○	
GS ( k (cn=48, fn=81)	PDF417: Print symbol data of symbol saving region	○		○	○	
GS ( k (cn=48, fn=82)	PDF417: Send size information of symbol data in symbol saving region	○		○	○	
GS ( k (cn=49, fn=65)	QR Code: Set model		○	○	○	
GS ( k (cn=49, fn=67)	QR Code: Set module size		○	○	○	
GS ( k (cn=49, fn=69)	QR Code: Set error correction level		○	○	○	
GS ( k (cn=49, fn=80)	QR Code: Store data in symbol saving region		○	○	○	
GS ( k (cn=49, fn=81)	QR Code: Print symbol data of symbol saving region	○		○	○	
GS ( k (cn=49, fn=82)	QR Code: Send size information of symbol data in symbol saving region	○		○	○	
GS /	Print download bit images	○		(D)	○	
GS :	Start/end macro definition	○	○	○	○	
GS B	Specify/cancel white/black inverted printing		○	○	○	
GS C 0	Set counter print mode		○	○	○	
GS C 1	Set Counter Mode (A)		○	○	○	
GS C 2	Set counter value		○	○	○	
GS C ;	Set Counter Mode (B)		○	○	○	
GS E	Set print speed		○	○	○	
GS H	Select HRI character print position		○	○	○	
GS I	Send Printer ID	○		○	○	
GS L	Set left margin		○	(L)	(S)	○
GS P	Set basic calculation pitch		○	○	○	
GS T	Move to top of line	○		○	Ignored	
GS V	Cut paper	○		(L)	○	○
GS W	Set print region width		○	(L)	(S)	○
GS \	Specify relative position for character vertical direction in page mode	○		Ignored	○	○
GS ^	Execute macro	○		○	○	
GS b	Specify/cancel smoothing		○	○	○	
GS c	Print counter	○		○	○	
GS f	Select HRI character font		○	○	○	
GS h	Set bar code height		○	○	○	
GS k	Print bar code	○		(D)	○	
GS r	Transmission of status	○		○	○	
GS v 0	Print raster bit images	○		(D)	Invalid	
GS w	Set bar code horizontal size		○	○	○	



**Kanji Control Commands (For Japanese, Chinese and Taiwanese language specifications only)**

Commands	Name	Command Class		Std Mode	Page Mode	GS P Effect
		Exe.	Set.			
FS !	Batch specify Chinese character print mode		○	○	○	
FS &	Specify Chinese character mode		○	○	○	
FS -	Specify/cancel Chinese character underline		○	○	○	
FS .	Cancel Chinese character mode		○	○	○	
FS 2	Define external character		○	○	○	
FS C	Select Chinese character code type		○	○	○	
FS S	Set Chinese character space amount		○	○	○	○
FS W	Specify/cancel double-tall, double wide Chinese characters		○	○	○	

**ESC/POS Black Mark Related Commands**

Commands	Name	Command Class		Std Mode	Page Mode	GS P Effect
		Exe.	Set.			
FF	Print and recover to page mode + TOF and Cut	○		○	○	
DLE ENQ	Real-time request to printer	○		○	○	
GS FF	Move to BM detection position	○		○	○	
GS ( F	Adjust BM detection position		○	○	○	○
GS ( M n=1	Save black mark adjustment amount	○		○	○	
GS ( M n=2	Load black mark adjustment amount	○		○	○	
GS ( M n=3	Set auto-load of black mark adjustment amount		○	○	○	
GS <	Mechanically initialize printer	○		○	○	
GS V	Cut paper	○		(L)	○	○

**STAR Original Commands**

Commands	Name	Command Class		Std Mode	Page Mode	GS P Effect
		Exe.	Set.			
ESC GS =	Write data to a blank code page		○	○	○	
ESC GS t	Select character code table		○	○	○	
ESC GS +	Macro registration	○	○	○	○	
ESC GS #m	Memory switch settings	○	○	○	○	
ESC RS F	Select font		○	○	○	
ESC RS C	Print mode selection	○	○	○	○	
ESC RS L	Batch control logos	○		○		
ESC GS ETX	Send print-end counter, initialize	○		○	○	
	Cancel print data feature		○	○		
	Set data time out		○	○		

**STAR Original Presenter Control Commands**

Commands	Name	Command Class		Std Mode	Page Mode	GS P Effect
		Exe.	Set.			
ESC SYN 0	Execute presenter paper recovery	○		○	○	
ESC SYN 1	Set presenter paper recovery time		○	○	○	
ESC SYN 3	Get presenter counter		○	○	○	
ESC SYN 4	Initialize presenter counter		○	○	○	
ESC GS SUB DC1	Specify snout operation mode		○	○	○	
ESC GS SUB DC2	Set snout LED ON/OFF time		○	○	○	
ESC GS SUB DC3	Output snout LED	○		○	○	

**STAR Original Mark Commands**

Commands	Name	Command Class		Std Mode	Page Mode	GS P Effect
		Exe.	Set.			
ESC GS * 0	Print mark	○		(D)	Ignored	
ESC GS *1	Set mark height and line feed		○	○	○	
ESC GS *2	Set mark color and horizontal width		○	○	○	
ESC GS *W	Register mark format to non-volatile memory	○	○	○	○	
ESC GS *C	Initialize mark format in the non-volatile memory	○	○	○	○	

**STAR Original Auto Logo Commands**

Commands	Name	Command Class		Std Mode	Page Mode	GS P Effect
		Exe.	Set.			
ESC GS /W	Register Auto Logo setting to non-volatile memory	○	○	○	○	
ESC GS /C	Initialize Auto Logo setting to non-volatile memory	○	○	○	○	
ESC GS /1	Auto Logo function on/off setting		○	○	○	
ESC GS /2	Set command character		○	○	○	
ESC GS /3	Set user macro 1		○	○	○	
ESC GS /4	Set user macro 2		○	○	○	
ESC GS /5	Set command character switching method		○	○	○	
ESC GS /6	Set partial cut before Auto Logo printing		○	○	○	

**STAR Original Buzzer Commands**

Commands	Name	Command Class		Std Mode	Page Mode	GS P Effect
		Exe.	Set.			
ESCSBEL	Ring buzzer	○	○	○		
ESCSMDC1	External buzzer drive pulse condition settings	○	○	○		
ESCSMDC2	External buzzer drive execution	○	○	○		

**STAR Original PDF417 Commands**

Commands	Name	Command Class		Std Mode	Page Mode	GS P Effect
		Exe.	Set.			
ESCSxS0	Set PDF417 bar code size		○	○	○	
ESCSxS1	Set PDF417 ECC (security level)		○	○	○	
ESCSxS2	Set PDF417 module X direction size		○	○	○	
ESCSxS3	Set PDF417 module aspect ratio		○	○	○	
ESCSxD	Set PDF417 bar code data		○	○	○	
ESCSxP	Print PDF417 bar code	○		○	○	
ESCSxl	Get PDF417 bar code expansion information	○		○	○	

**STAR Original Print Starting Trigger Control Commands**

Commands	Name	Command Class		Std Mode	Page Mode	GS P Effect
		Exe.	Set.			
ESCGSg0	Print starting trigger	○		○		
ESCGSg1	Set print starting timer		○	○		

**STAR Original QR Code Commands**

Commands	Name	Command Class		Std Mode	Page Mode	GS P Effect
		Exe.	Set.			
ESCGSyS0	Set QR code model		○	○	○	
ESCGSyS1	Set QR code mistake correction level		○	○	○	
ESCGSyS2	Set QR code cell size		○	○	○	
ESCGSyD1	Set QR code data (auto)		○	○	○	
ESCGSyD2	Set QR code data (manual)		○	○	○	
ESCGSyP	Print QR code	○		○	○	
ESCGSyI	Get QR code expansion information	○		○	○	

**STAR Original Page Function Commands**

Commands	Name	Command Class		Std Mode	Page Mode	GS P Effect
		Exe.	Set.			
ESCGSh0	Invert 180°		○	○		
ESCGSh1	Water Mark		○	○	○	

**Star Original Reduced Printing Function Command**

Commands	Name	Command Class		Std Mode	Page Mode	GS P Effect
		Exe.	Set.			
ESCGSc	Reduced printing		○	○		

### Star Original Text Search Commands

Commands	Name	Command Class		Std Mode	Page Mode	GS P Effect
		Exe.	Set.			
ESC GS ) B (fn = 48)	Enable and disables text search		○	○	○	
ESC GS ) B (fn = 49)	Set the number of times to run the text search macro		○	○	○	
ESC GS ) B (fn = 50)	Set to print the string that matches in the text search		○	○	○	
ESC GS ) B (fn = 64)	Define the text search string		○	○	○	
ESC GS ) B (fn = 65)	Define the text search macro		○	○	○	
ESC GS ) B (fn = 66)	Define the timing of the text search macro execution		○	○	○	
ESC GS ) B (fn = 80)	Register text search settings and definitions in the non-volatile memory		○	○	○	
ESC GS ) B (fn = 81)	Initialize text search settings and definitions		○	○	○	
ESC GS ) B (fn = 96)	Print the text search settings and definitions	○		○	○	
ESC GS ) B (fn = 97)	Run the text search macro	○		○	○	

### Star Original Printer information transmission Command

Commands	Name	Command Class		Std Mode	Page Mode	GS P Effect
		Exe.	Set.			
ESC GS ) I (fn=48)	Send the all kind of multibyte fonts	○		○	○	

### Star Original Individual Logo Command

Commands	Name	Command Class		Std Mode	Page Mode	GS P Effect
		Exe.	Set.			
ESC GS ) L (fn = 48)	Send the registered individual logo CRC	○		○	○	
ESC GS ) L (fn = 49)	Send the registered individual NV graphics memory capacity	○		○	○	
ESC GS ) L (fn = 50)	Send all key code of the registered NV graphics	○		○	○	

### Star Original Audio Commands

Commands	Name	Command Class		Std Mode	Page Mode	GS P Effect
		Exe.	Set.			
ESC GS s O	Playback NV Audio	○		○	○	
ESC GS s P	Stop NV Audio	○		○	○	
ESC GS s R	Playback received audio	○		○	○	
ESC GS s I	Register automatic audio setting information		○	○	○	
ESC GS s U	Register user area NV audio data		○	○	○	
ESC GS s T	Batch Playback NV Audio	○		○	○	

### Star Original Hold print control Command

Commands	Name	Command Class		Std Mode	Page Mode	GS P Effect
		Exe.	Set.			
ESC SYN DC3	Hold print control settings		○	○	○	
ESC SYN DC4	Hold print status control settings		○	○	○	
ESC GS ) s	Send paper hold sensor installation data.	○		○	○	

## 4. COMMAND DETAILS

### 4-1 Explanation of Terms

- **Reception buffer**

The buffer for storing data (reception data) received from the host, as it is called the reception buffer. Reception data is temporarily stored in the reception buffer, then processed sequentially.

- **Print buffer**

The buffer for storing image data for printing is called the print buffer.

- **Print buffer full**

The state in which the buffer has no more space available is called print buffer full. When the print buffer is full in standard mode, data in the print buffer is printed and a line feed is performed when new print data is processed. This is the same as a LF. When the print buffer is full in the page mode, the printer move the print position to the head of the next line then starts with the new print data.

- **Top of line**

The top of line is a state that satisfies the following conditions.

1. There is currently no print data in the print buffer.
2. There is no skipped portion using HT
3. A print position has not been specified using ESC\$, and ESC \

- **Printable region**

This is the maximum printable area with the printer's specifications.

- **Print region**

This is the printing area specified by a command. (Print region  $\leq$  printable region)

- ANK character base line

1. Normal direction characters FONT-A/FONT-B (Standard Mode/Page Mode)

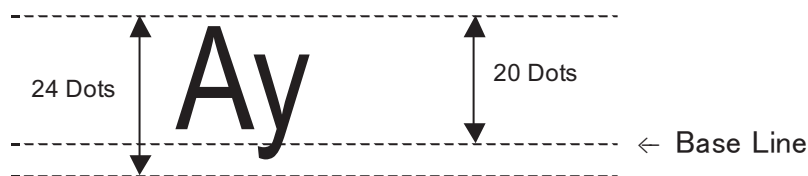

2. Rotated characters FONT-A (Standard Mode)

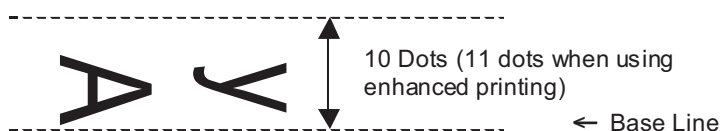

3. Rotated characters FONT-B (Standard Mod



• Chinese character base line

- 1. Normal direction character (Standard Mode/Page Mode)

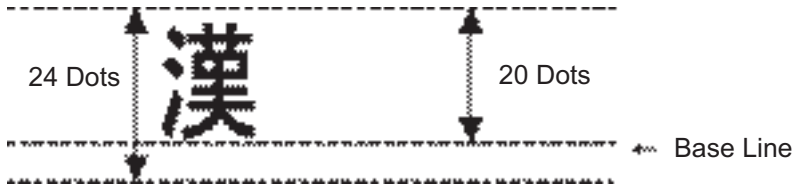

- 2. Rotated characters (Standard Mode)

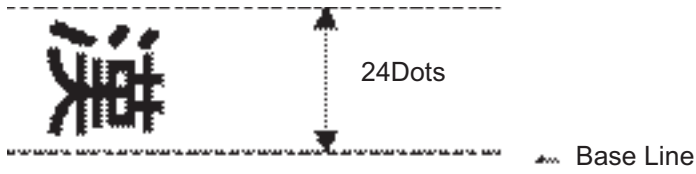

• ASB Function

Sends the automatic status to the host each time the printer's status changes.

## 4-2 Exception Processing

### 1. Undefined codes

Codes from <00>H to <1F>H are targeted. When codes not defined as commands in this region are received, they are discarded.

(Ex.) If processing the data string of <30>H<31>H<03>H<32>H<0A>H<33>H, the printer will discard <03>H as an undefined code.

### 2. Undefined commands

When data continuing the codes of ESC, FS, GS, DLE are codes not defined as commands, ESC, FS, GS, DLE and subsequent codes are discarded.

(Ex.) If processing the data string of <30>H<1B>H<22>H<31>H<32>H, the printer will read and discard <1B>H<22>H as an undefined command.

### 3. Settings outside of the defined area

Processing values outside of the defined area in commands accompanying arguments, those commands are ignored and the preset values are unchanged. The processing of commands is terminated at the point values outside of the defined region are processed in arguments having a plurality of commands.

(Ex.) If processing the data string of <1B>H<52>H<15>H, the printer will discard the data string of <1B>H<52>H<15>H because although <1B>H<52>H is defined as a commands (ESC R), the argument <15>H is outside of the definition. Therefore, the international character set that is already set experiences no change.

### 4. Real-time Commands

Real-time commands are stored in the reception buffer.



## 4-3 Command Details

### 4-3-1 Standard Commands

#### HT

Name	Horizontal tab
Code	ASCII     HT
	Hex.       09
	Decimal    9
Function	Moves print position to next horizontal tab position.
Details	<ul style="list-style-type: none"> <li>• This command is ignored if the next tab is not set.</li> <li>• If the next tab position exceeds the print region, the print position is moved to [print region + 1].</li> <li>• The horizontal tab position is set by ESC D (Set/cancel horizontal tab position).</li> <li>• When the print position is at the [print region + 1] position and this command is received, the current line buffer full is printed and a horizontal tab is executed from the top of the next line.</li> <li>• The initial value of the horizontal tab position is every 8 characters of Font A (the 9<sup>th</sup>, 17<sup>th</sup>, 25<sup>th</sup> positions, etc.)</li> </ul>
Reference	ESC D

**LF**

Name	Line feed
Code	ASCII      LF
	Hex.        0A
	Decimal     10
Function	Prints the data in the print buffer and performs a line feed based on the set line feed amount.
Details	After execution, makes the top of the line the next print starting position.
STAR	When the setting for the line feed amount is smaller than the print data height: a. If there is no print data, a line feed operation is executed according to the line feed amount. b. If there is print data, a line feed operation is executed for the height of the print data.
Reference	See ESC 2, ESC 3, Appendix-1

## FF

Name	Print and recover to page mode
Code	ASCII      FF
	Hex.        0C
	Decimal    12
Function	Prints all buffered data to the print region collectively, then recovers to the standard mode.
Details	<ul style="list-style-type: none"> <li>• All buffer data is deleted after printing.</li> <li>• The print area set by ESC W (Set print region in page mode) is reset to the default setting.</li> <li>• No paper cut is executed.</li> <li>• Sets the print position to the beginning of the next line after execution.</li> <li>• This command is enabled only in page mode.</li> </ul>
Reference	ESC FF, ESC L, ESC S

**CR**

Name	Print and carriage return	
Code	ASCII      CR	
	Hex.        0D	
	Decimal     13	
Function	<ul style="list-style-type: none"><li>• When an automatic line feed is enabled, this command functions in the same way as LF (print and line feed). When the automatic line feed is disabled, this command is ignored.</li></ul>	
Details	<ul style="list-style-type: none"><li>• This command is ignored with serial interface models.</li><li>• The operations of this command are selected by the memory switch &lt;CR&gt; code: Ignore/ same as &lt;LF&gt; for parallel interface models.</li><li>• Sets the print position to the beginning of the next line after execution.</li></ul>	
	Reference	LF

**CAN**

Name	Cancel print data in page mode	
Code	ASCII	CAN
	Hex.	18
	Decimal	24
Function	Deletes all print data in the currently set print region in page mode.	
Details	• This command is enabled only in page mode.	
	• Portions included in the currently set print region are also deleted, even if previously set print region data.	
Reference	ESC L, ESC W	

## DLE EOT n

Name	Real-time status transmission												
Code	<table border="0"> <tr> <td>ASCII</td> <td>DLE</td> <td>EOT</td> <td>n</td> </tr> <tr> <td>Hex.</td> <td>10</td> <td>04</td> <td>n</td> </tr> <tr> <td>Decimal</td> <td>16</td> <td>4</td> <td>n</td> </tr> </table>	ASCII	DLE	EOT	n	Hex.	10	04	n	Decimal	16	4	n
ASCII	DLE	EOT	n										
Hex.	10	04	n										
Decimal	16	4	n										
Defined Region	Spec. A: $1 \leq n \leq 4$ Spec. B: $1 \leq n \leq 5$												
Function	Transmits the status specified by n in real-time. n = 1: Transmit printer status n = 2: Transmit offline cause status n = 3: Transmit error cause status n = 4: Transmit continuous paper detector status n = 5: Transmit presenter paper detector status												
Details	<ul style="list-style-type: none"> <li>• The printer transmits the present status.</li> <li>• Each status is represented by one-byte of data.</li> <li>• The printer transmits statuses without confirming whether the host computer can receive data.</li> <li>• This command is executed even when the printer is offline, the reception buffer is full, or there is an error status.</li> <li>• The printer executes this command upon reception.</li> <li>• This command is executed even when the printer is offline, the reception buffer is full, or there is an error status on serial interface models.</li> <li>• This command cannot be executed when the printer is busy on parallel interface models. The printer will not enter a BUSY status when offline or when there is an error when BUSY condition of reception buffer full, offline/reception buffer full is handled as a reception buffer full in the DIP switch settings.</li> <li>• When ASB is enabled, the status transmitted by this command and the ASB status must be differentiated. See Appendix-2 for details on how to identify.</li> <li>• This command is enabled even when the printer specification is disabled by ESC = (select peripheral devices).</li> <li>• See Appendix-2 for details on statuses.</li> </ul> <p>Spec. B-1: Transmit printer status within 2msec.            Spec. B-2: Transmit printer status within 10msec.</p>												
Notes:	<ul style="list-style-type: none"> <li>• Operators must use caution for other commands when the data string of <math>\langle 10 \rangle H \langle 04 \rangle H \langle n \rangle</math> (Spec. A: <math>1 \leq n \leq 4</math>, Spec. B: <math>1 \leq n \leq 5</math>) is received because it operates in the same manner as this command. Example: In ESC * m nL nH [d1...dk], d1=<math>\langle 10 \rangle H</math>, d2=<math>\langle 04 \rangle H</math>, d3=<math>\langle 01 \rangle H</math></li> <li>• Do not use this command to interrupt code strings of other commands that consist of 2 or more codes.</li> </ul> <p>Example: If you attempt to transmit DLE EOT 3 up to transmitting ESC3 by trying to transmit ESC 3 n from the host, it is processed as ESC 3 <math>\langle 10 \rangle H</math>. Operators must use caution.</p>												
Reference	DLE ENQ, GS r, Appendix-2												

## DLE ENQ n

Name	Real-time request to printer												
Code	<table border="0"> <tr> <td>ASCII</td> <td>DLE</td> <td>ENQ</td> <td>n</td> </tr> <tr> <td>Hex.</td> <td>10</td> <td>05</td> <td>n</td> </tr> <tr> <td>Decimal</td> <td>16</td> <td>5</td> <td>n</td> </tr> </table>	ASCII	DLE	ENQ	n	Hex.	10	05	n	Decimal	16	5	n
ASCII	DLE	ENQ	n										
Hex.	10	05	n										
Decimal	16	5	n										
Defined Region	$1 \leq n \leq 2$												
Function	<p>Responds to requests n specifications from the host in real-time. n specifications are below.</p> <p>n = 1: Recover from the error and start printing from the line where the error occurred.</p> <p>n = 2: Recover from error after clearing the reception buffer and print buffer.</p>												
Details	<ul style="list-style-type: none"> <li>• This command is enabled even when the printer specification is disabled by ESC = (select peripheral devices).</li> <li>• This command is enabled only when an auto-cutter error occurs.</li> <li>• This command is processed upon reception.</li> <li>• This command is executed even when the printer is offline, the reception buffer is full, or there is an error status on serial interface models.</li> <li>• This command cannot be executed when the printer is busy on parallel interface models. The printer will not enter a BUSY status when offline or when there is an error when BUSY condition of reception buffer full, offline/reception buffer full is handled as a reception buffer full.</li> <li>• The printer retains the settings by ESC !, ESC 3, that were in effect when an error occurred even when DLE ENQ 2 is executed. The printer is initialized completely using this command and ESC @.</li> </ul>												
Notes:	<ul style="list-style-type: none"> <li>• Operators must use caution for other commands when the data string of &lt;10&gt;H&lt;05&gt;H&lt;n&gt; (<math>1 \leq n \leq 2</math>) is received because it operates in the same manner as this command. Example: In ESC * m nL nH [d]k; d1 = &lt;10&gt;H; d2 = &lt;05&gt;H; d3 = &lt;01&gt;H</li> <li>• Do not use this command to interrupt code strings of other commands that consist of 2 or more codes. Example: If you attempt to transmit DLE EBQ 2 up to transmitting ESC3 by trying to transmit ESC 3 n from the host, it is processed as ESC 3 10H. Operators must use caution.</li> </ul>												
STAR	<ul style="list-style-type: none"> <li>• Auto-cutter error specifications vary according to model, so for models for which there are non-recoverable auto-cutter errors, three bytes of this command are ignored. See Appendix-2 for details on auto-cutter error specifications for model types.</li> <li>• Models connected to a presenter ignore this command.</li> <li>• When this command is set to n = 2, the printer is reset.</li> </ul>												
Reference	DLE EOT, Appendix-2												

## DLE DC4 n m t

Name	Real-time output of specified pulse					
Code	ASCII	DLE	DC4	n	m	t
	Hex.	10	14	n	m	t
	Decimal	16	20	n	m	t
Defined Region	n = 1					
	m = 0,1					
	$1 \leq t \leq 8$					
Function	<p>This outputs a signal specified by t to the connector pin specified by m.</p> <p>m = 0: #2 Pin of the drawer kick connector</p> <p>m = 1: #5 Pin of the drawer kick connector</p> <p>On time is set to t x 100 msec; Off time is set to t x 100 msec.</p>					
Details	<ul style="list-style-type: none"> <li>• This command is ignored if the printer experiences an error while processing this command.</li> <li>• This command is ignored while outputting the pulse (while executing either ESC p or DEL DC4) to the connector pin while processing this command.</li> <li>• This command is processed upon reception.</li> <li>• This command is executed even when the printer is offline, the reception buffer is full, or there is an error status on serial interface models.</li> <li>• This command cannot be executed when the printer is busy on parallel interface models. The printer will not enter a BUSY status when offline or when there is an error when BUSY condition of reception buffer full, offline/reception buffer full is handled as a reception buffer full in the DIP switch settings.</li> <li>• This command is enabled even when the printer specification is disabled by ESC = (select peripheral devices).</li> </ul>					
Notes:	<ul style="list-style-type: none"> <li>• Operators must use caution for other commands when a data string that is the same as this command is received because it operates in the same manner as this command.</li> <li>• Do not use this command to interrupt code strings of other commands that consist of 2 or more codes.</li> </ul>					
STAR	<p>Printing and drawer drive cannot be performed simultaneously. Therefore, this command is processed when data has been read out from the reception buffer. If the printer is printing, this waits for the printing to end to drive the drawer, so real-time operation is not possible using the reception buffer status.</p>					
Reference	ESC p					



## ESC FF

Name	Print data in page mode		
Code	ASCII	ESC	FF
	Hex.	1B	0C
	Decimal	27	12
Function	Prints all buffered data in the print area collectively in page mode.		
Details	<ul style="list-style-type: none"> <li>• This command is enabled only in page mode.</li> <li>• Holds the following information after printing.               <ol style="list-style-type: none"> <li>a. Expanded data</li> <li>b. Character print direction selection in page mode (ESC T)</li> <li>c. Set print region (ESC W) in the page mode.</li> <li>d. Character expansion position</li> </ol> </li> </ul>		
Reference	FF, ESC L, ESC S		

**ESC SP n**

Name	Set character right space amount			
Code	ASCII	ESC	SP	n
	Hex.	1B	20	n
	Decimal	27	32	n
Defined Region	$0 \leq n \leq 255$			
Initial Value	n = 0			
Function	Sets the right space amount for the character to [n x basic calculated pitch].			
Details	<ul style="list-style-type: none"> <li>• If the character horizontal direction magnification ratio is more than 2, the right space amount is also enlarged accordingly.</li> <li>• This command does not affect Chinese characters.</li> <li>• Right space amounts can be set independently for both the standard and page modes.</li> <li>• The basic calculated pitch is set by GSP (Set basic calculated pitch). Also, after setting the right space amount, it is not affected even if the basic calculated pitch is changed.</li> <li>• If the calculation results in fractions, the pitch is corrected to a minimal mechanical pitch and the rest is discarded.</li> <li>• In standard mode, the basic calculated pitch (x) for the horizontal direction is used.</li> <li>• The ANK character width is (“left space amount” + “ANK font dot count” + “right space amount”) x (basic calculated pitch). (See the information on character specifications in the appropriate printer specifications manual for details on the ANK font dot count.)</li> <li>• In page mode, the basic calculated pitch that is used according to the starting point varies.               <ol style="list-style-type: none"> <li>a. When the starting point is specified to be upper left or lower right by the ESC T command (Character print direction selection in page mode), the basic calculated pitch (x) for the horizontal direction is used.</li> <li>b. When the starting point is specified to be upper right or lower left by the ESC T command (Character print direction selection in page mode), the basic calculated pitch (y) for the horizontal direction is used.</li> </ol> </li> <li>• The maximum value that can be set for the right space amount is approximately 35.983 mm (or 255/180 inch). Specifications that exceed the maximum value are rounded off to that value.</li> </ul>			
Reference	GS P			

**ESC ! n**

Name Batch specify print mode  
 Code ASCII ESC ! n  
 Hex. 1B 21 n  
 Decimal 27 33 n  
 Defined Region  $0 \leq n \leq 255$   
 Initial Value  $n = 0$   
 Function Specifies batch print mode

Bit	Function	"0"	"1"
7	Underline	OFF	ON
6	Undefined	--	--
5	Double wide expanded	OFF	ON
4	Double tall expanded	OFF	ON
3	Emphasized printing .	OFF	ON
2	Undefined		--
1	Undefined	--	--
0	Character Fonts	Font-A	Font-B

- Details
- Quadruple-size characters are printed by specifying both double-tall (bit 4 = 1) and double-wide (bit 5 = 1) modes.
  - An underline is applied to the entire character width, including the ESC SP (character right space amount). However, underlines are not applied to portions that have been skipped using HT (horizontal tab) or ESC V (character 90 degree rotation).
  - The thickness of the underline is set by ESC - (specify/cancel underlines) regardless of the character.
  - The base line for characters is the same when there are characters having different vertical direction ratios in the same line.
  - The setting of the last received command is effective even when emphasized printing is executed by the ESC E (specify/cancel emphasized printing) command.
  - The setting of the last received command is effective even when underlines are executed by the (ESC -) Specify/cancel underline command.
  - The setting of the last received command is effective even when character size is executed by the GS! command.
  - Emphasized printing (bit 3) is effective for ANK and Chinese characters. Other printing modes are effective only on ANK characters. • Specifications using this command are ignored in HRI characters.

STAR The following are the font configurations on STAR printers.

Character Fonts	Horizontal Dots x Vertical Dots
Font A	12 x 24 Dots
Font B	9 x 24 Dots
Chinese Character Fonts	24 x 24 Dots

Reference ESC -, ESC E, GS !

**ESC \$ nL nH**

Name	Specify absolute position
Code	ASCII    ESC    \$    nL    nH
	Hex.      1B    24    nL    nH
	Decimal    27    36    nL    nH
Defined Region	$0 \leq nL \leq 255$
	$0 \leq nH \leq 255$
Function	Specifies the next printing starting position using an absolute position based on the left margin position. The next printing starting position is the position specified by $[(nL+nH \times 256) \times \text{basic calculated pitch}]$ from the left margin position.
Details	<ul style="list-style-type: none"> <li>• Specifications exceeding the print range are ignored.</li> <li>• The basic calculated pitch is set by GSP (Set basic calculated pitch).</li> <li>• If the calculation results in fractions, the pitch is corrected to a minimal mechanical pitch and the rest is discarded.</li> <li>• In standard mode, the basic calculated pitch (x) for the horizontal direction is used.</li> <li>• In page mode, the basic calculated pitch that is used according to the starting point varies.             <ol style="list-style-type: none"> <li>a. When the starting point is specified to be upper left or lower right by the ESC T command (Character print direction selection in page mode), the basic calculated pitch (x) for the horizontal direction is used.</li> <li>b. When the starting point is specified to be upper right or lower left by the ESC T command (Character print direction selection in page mode), the basic calculated pitch (y) for the horizontal direction is used.</li> </ol> </li> </ul>
STAR	Top of line does not exist when this command is used to specify anything other than the left margin position. The top of the line is maintained only when the same position as the left margin position is specified.
Reference	ESC \ , GS \$, GS \ , GS P

## ESC % n

Name	Specify/cancel download character set			
Code	ASCII	ESC	%	n
	Hex.	1B	25	n
	Decimal	27	37	n
Defined Region	$0 \leq n \leq 255$			
Initial Value	n = 0			
Function	Specifies or cancels the download character set. <ul style="list-style-type: none"> <li>• When n = &lt;*****0&gt;B, the download character set is cancelled.</li> <li>• When n = &lt;*****1&gt;B, the download character set is specified.</li> </ul>			
Details	<ul style="list-style-type: none"> <li>• n is effective only when it is the least significant bit.</li> <li>• When the download character set is cancelled, the internal character set is automatically specified.</li> </ul>			
STAR	Because ESC& (define download characters) and GS* (define download bit images) are used in the same region, they cannot both be defined simultaneously. <ol style="list-style-type: none"> <li>a. When download characters are defined, previously defined download bit images are cleared.</li> <li>b. Conversely, when download bit images are defined, previously defined download characters are cleared and the definition returns to same the internal character set.</li> </ol>			
Reference	ESC &, ESC ?			

**ESC& yc1c2 [x1d1...d (y x x1) ] ... [axd1...d (yxax)]**

Name	Define download characters
Code	ASCII    ESC    &    y    c1c2 [x1 d1 ... d (yX x1)] ... [a xd1 ... d (y× ax)] Hex.        1B    26    y    c1c2 [x1 d1 ... d (yX x1)] ... [a xd 1 ... d (y×ax)] Decimal    27    38    y    c1c2 [x1 d1 ... d (yX x1)] ... [a xd 1 ... d (y×ax)]
Defined Region	y = 3 $32 \leq c1 \leq c2 \leq 126$ $0 \leq x \leq 12$ (Font A), $0 \leq x \leq 9$ (Font B) $0 \leq d1...d (y×ax) \leq 255$
Initial Value	Same pattern as internal character set
Function	Defines the download characters to the specified character code. <ul style="list-style-type: none"> <li>• y specifies the number of bytes in the vertical direction.</li> <li>• c1 specifies the starting character code for the definition; c2 specifies the final character code.</li> <li>• x specifies the number of dots in the horizontal direction for the definition.</li> </ul>
Details	<ul style="list-style-type: none"> <li>• The definable character code range is from ASCII code &lt;20&gt;H to &lt;7E&gt;H.</li> <li>• It is possible to define multiple characters for consecutive character codes with one definition. If only one character is desired, use c1 = c2.</li> <li>• If x=0, a space is registered.</li> <li>• d is the dot data for the characters. It indicates the horizontal direction x dot pattern from the left side. If x does not meet the number of dots configuring the character, any remaining dots on the right side are blank.</li> <li>• The data to define download characters is (y x x) bytes.</li> <li>• Bits that correspond to the dots to print are 1, and the bits that correspond to the dots that are not printed are 0 in the definition data.</li> <li>• This command can define different download characters for each font. To select a font, use ESC M or ESC !.</li> <li>• ESC &amp; (define download characters) and GS * (define download bit images) cannot both be defined simultaneously.</li> <li>a. When download characters are defined, previously defined download bit images are cleared.</li> <li>b. Conversely, when download bit images are defined, previously defined download characters are cleared and the definition returns to same the internal character set.</li> <li>• Defined download characters are cleared under the following executions.                         <ol style="list-style-type: none"> <li>a. When the printer is initialized (ESC@)</li> <li>b. When download bit images are defined (GS*)</li> <li>c. When download characters are deleted (ESC?)</li> <li>d. When NV bit images are defined (FSq)</li> <li>e. When the printer power is turned off</li> </ol> </li> </ul>
STAR	Font configurations and regions for effective parameters on STAR printers

Character Fonts	Horizontal Dots x Vertical Dots	y	x	Data Count
Font A	12 x 24 Dots	3	12	36 bytes
Font B	9 x 24 Dots	3	9	27 bytes

For the STAR printer, the font select commands, <ESC> <RS> F, can also be used.

Reference    ESC %, ESC ?

[Ex.:] When Font A (12 x 24) is selected

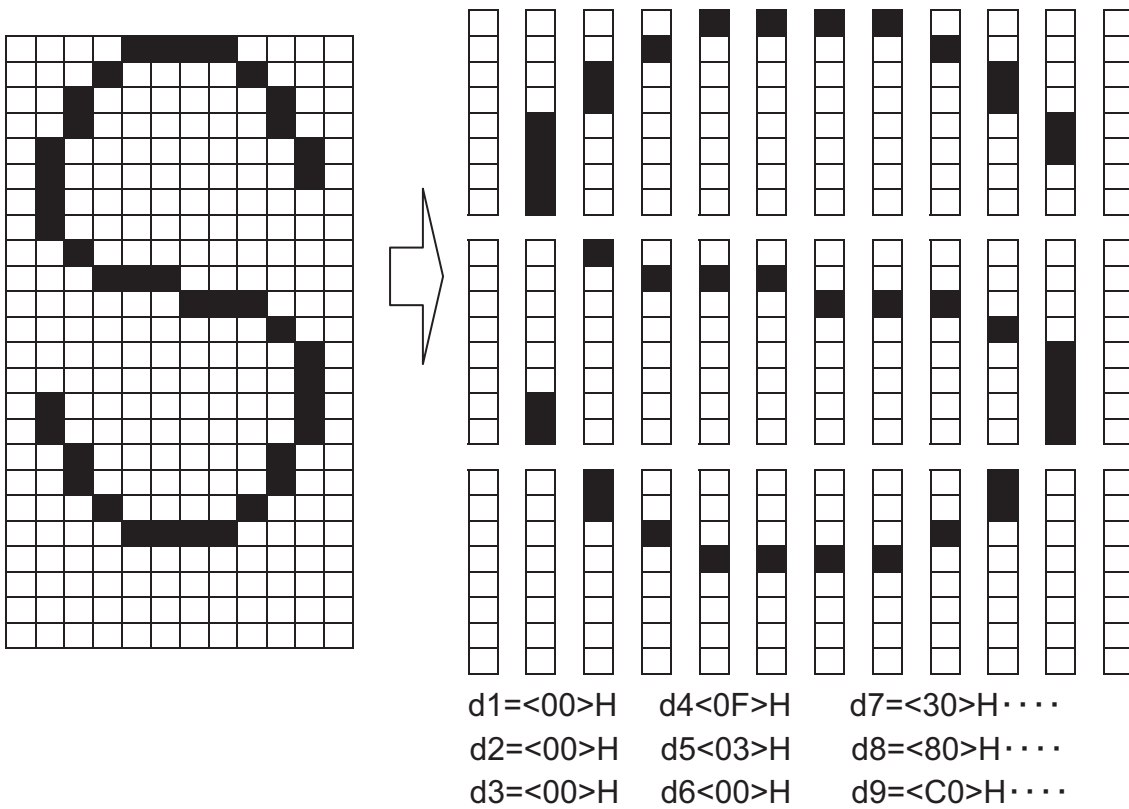
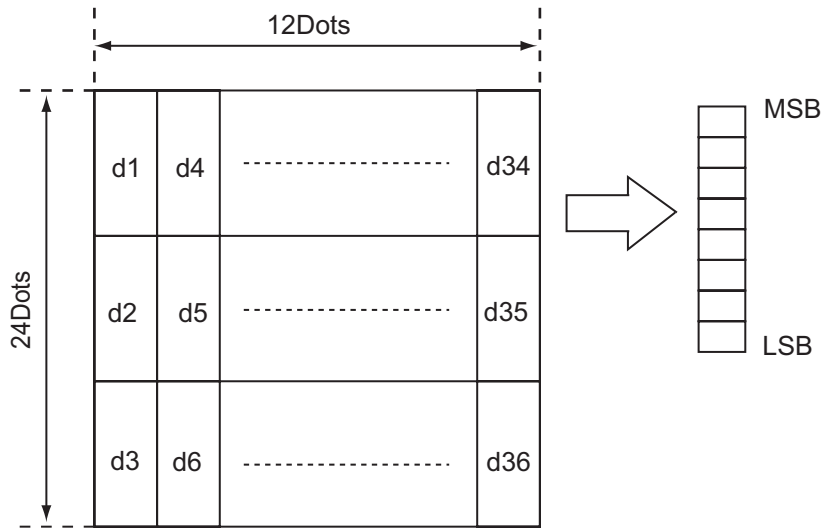

[Ex.:]

When Font B (9 x 24) is selected

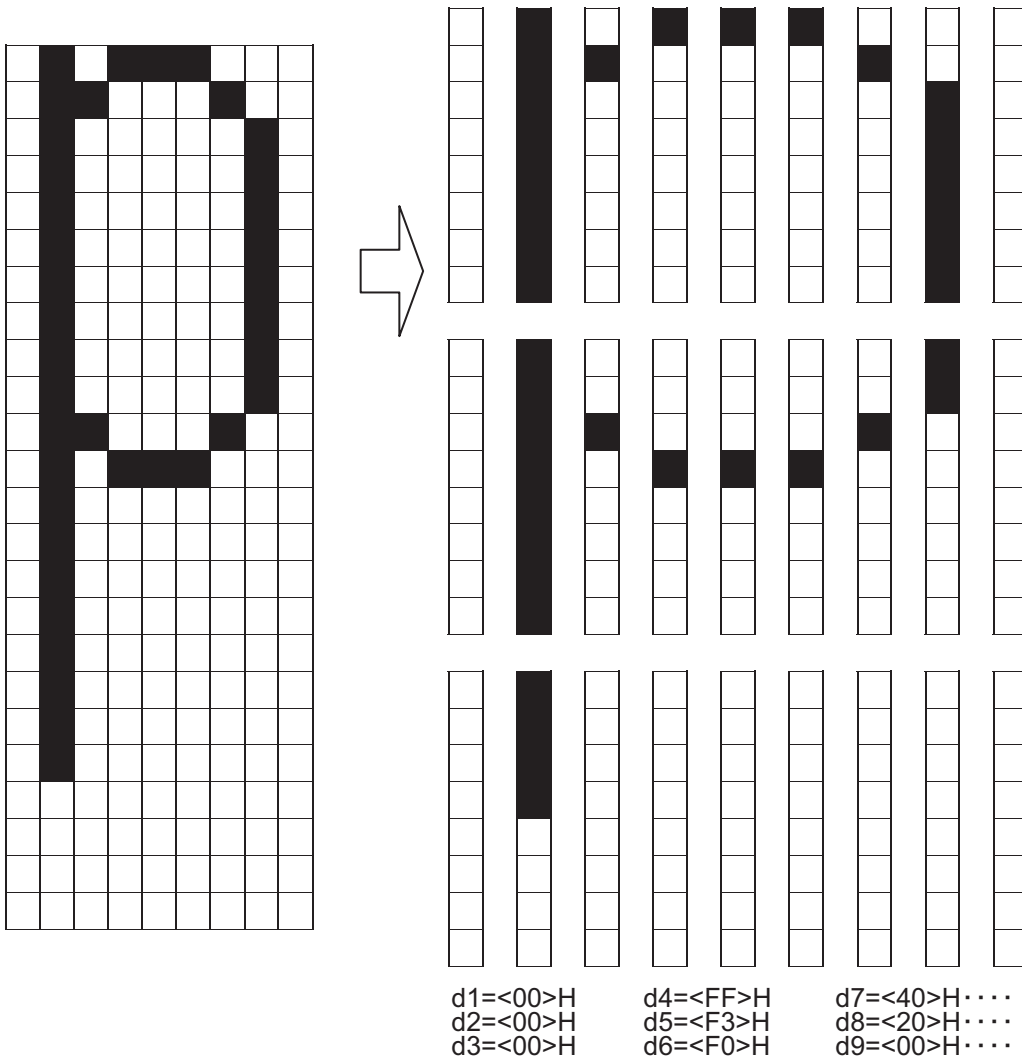
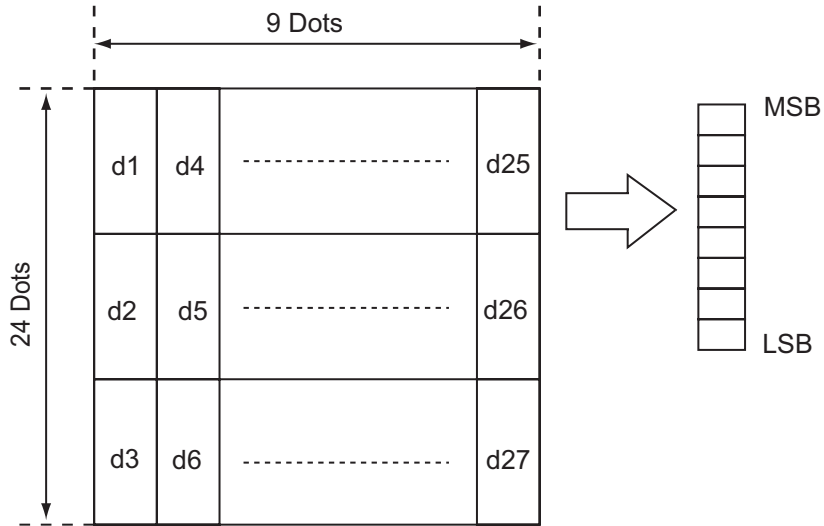



**ESC \* m nL nH d1...dk**

Name Specify bit image mode

Code	ASCII	ESC	*	m	nL	nH	d1...dk
	Hex.	1B	2A	m	nL	nH	d1...dk
	Decimal	27	42	m	nL	nH	d1...dk

 Defined Region  $m = 0, 1, 32, 33$ 
 $0 \leq nL \leq 255$ 

 Spec.A  $0 \leq nH \leq 3$ 

 Spec.B  $0 \leq nH \leq 7$ 
 $0 \leq d \leq 255$ 

 Function Selects a bit-image mode in mode  $m$  for the number of dots specified by  $nL$  and  $nH$ .

m	Mode	Number of Vert. Dir. Dots	Number of Hor. Dir. Dots	Density of Hor. Dir. Dots	Data Count (k)
0	8-dot single density	8	60 DPI	90 DPI	$nL+nH \times 256$
1	8-dot double density	8	60 DPI	180 DPI	$nL+nH \times 256$
32	24-dot single density	24	180 DPI	90 DPI	$(nL+nH \times 256) \times 3$
33	24-dot double density	24	180 DPI	180 DPI	$(nL+nH \times 256) \times 3$

## Details

- If the value of  $m$  is out of the specified range,  $nL$  and subsequent data are processed as normal data.
- $nL$  and  $nH$  indicate the number of dots in the bit image in the horizontal direction to print. The number of dots is calculated by  $(nL + nH \times 256)$ .
- If the bit-image data input exceeds the number of dots that can be printed on one line, the excess data is discarded.
- $d$  indicates the bit-image data. Bits that correspond to the dots to print are 1, and the bits that correspond to the dots that are not printed are 0.
- After processing bit images, the printer returns to normal data processing.
- Excluding upside-down printing, print modes (emphasized printing, double printing, underlines, character sizes and black/white inverted printing) are unaffected.
- For details on the bit image expansion position in the page mode, see section 2. Explanations of the Page Mode.

## STAR

- Dot density (when the STAR printer head = 203 DPI) on STAR printers.

m	Mode	Density of Vert. Direction Dots	Density of Hor. Direction Dots
0	8-dot single density	67 DPI	101 DPI
1	8-dot double density	67 DPI	203DPI
32	24-dot single density	203DPI	101 DPI
33	24-dot double density	203DPI	203DPI

- Fonts A and B and Chinese characters can be used together.

<8Dots Single Density>

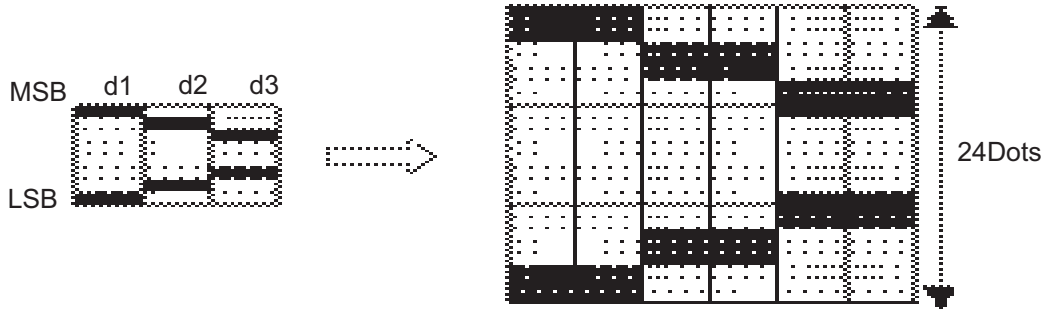

<8Dots Double Density>

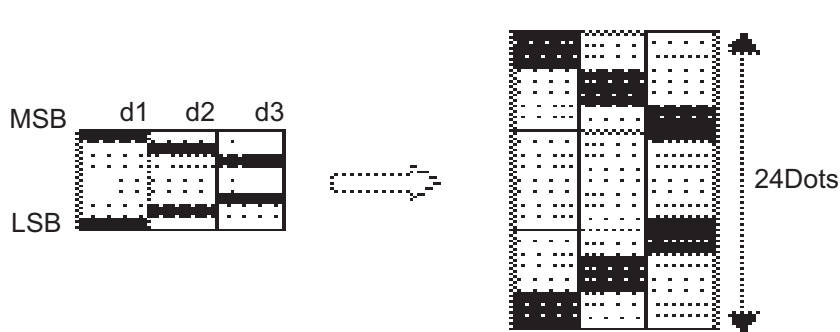

<24Dots Single Density>

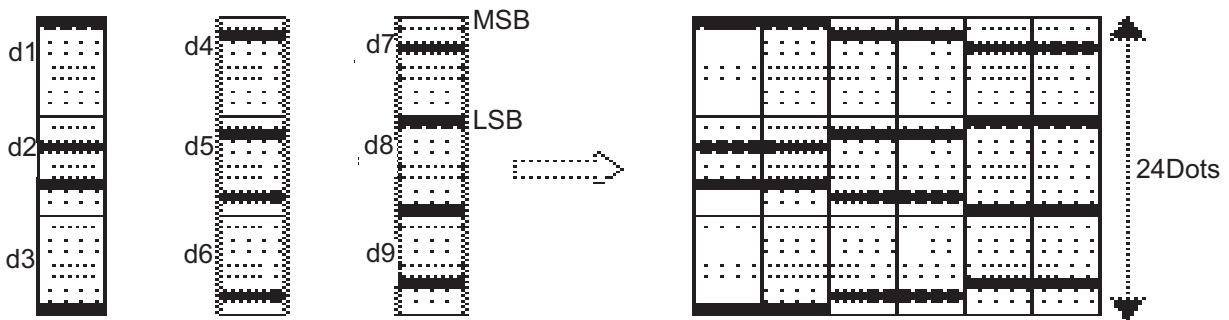

<24Dots Double Density>

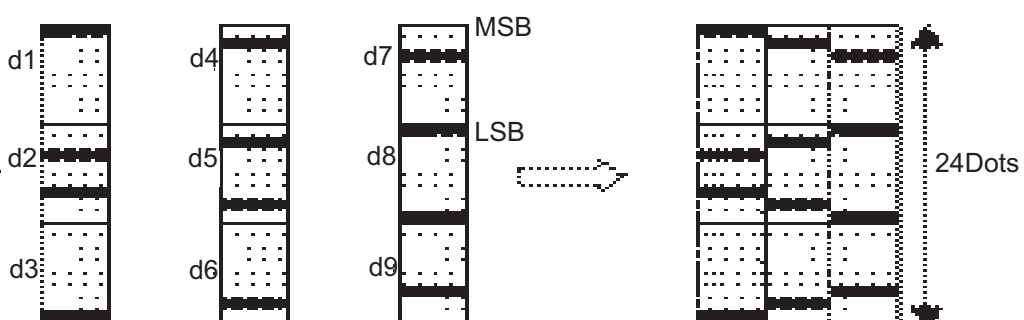

**ESC - n**

Name	Specify/cancels underline mode			
Code	ASCII	ESC	_	n
	Hex.	1B	2D	n
	Decimal	27	45	n
Defined Region	$0 \leq n \leq 2, 48 \leq n \leq 50$			
Initial Value	n = 0			
Function	Specifies or cancels underlines.			

n	Function
0, 48	Cancels underline
1, 49	Sets to one-dot width underline and specifies underlines.
2, 50	Sets to two-dot width underline and specifies underlines.

Details	<ul style="list-style-type: none"> <li>• An underline is applied to the entire character width, including the ESC SP (character right space amount). However, underlines are not applied to portions that have been skipped using HT (horizontal tab) or ESC V (character 90 degree rotation).</li> <li>• Underlines are not applied to ESCV (characters rotated 90 degrees clockwise) or GSB (black/white inverted characters).</li> <li>• When underline mode is cancelled by setting the value of n = 0 or n = 48, subsequent data is not underlined, and the underline thickness set before the mode is turned off is maintained.</li> </ul> <p>The default underline thickness is 1 dot.</p> <ul style="list-style-type: none"> <li>• Character size does not affect the set underline thickness.</li> <li>• Underline mode can also be turned on or off by using ESC ! (batch specify print mode). Note, however, that the last received command is effective. Therefore, if the underline mode is canceled using the ESC – command after specifying underlines using the ESC ! command, the ESC ! command is cancelled.</li> <li>• This command does not affect Chinese characters.</li> </ul>
STAR	<ul style="list-style-type: none"> <li>• Underlines are applied to the following positions for both Font A and Font B.</li> <li>• 1-dot thickness underline → 24<sup>th</sup> dot</li> <li>• 2-dot thickness underline → 23<sup>rd</sup> and 24<sup>th</sup> dot</li> </ul>
Reference	ESC !

## ESC 2

Name Set default line spacing

Code ASCII ESC 2  
Hex. 1B 32  
Decimal 27 50

Function Sets line feed amount per one line to approximately 4.23 mm (1/6 inch).

Details Line spacing can be set independently for both the standard and page modes.

STAR EPSON has models that have 180 DPI and 203 DPI print heads. STAR's print head is 203 DPI. Therefore, when targeting models with the EPSON 180 DPI print head, it is necessary to correct the line spacing that will generate from the difference in the head's print density.

In this case, the default line spacing on STAR printers is corrected to the following according to the basic calculated pitch correction. This does not apply for target models that have 203 DPI print heads, or models that do not require correction.

Basic Calculate Pitch Correction	Default Line Spacing
203 DPI	Approximately 4.23 mm (1/6 inch)
180 DPI	Approximately 3.75 mm

Reference ESC 3

**ESC 3 n**

Name	Set line feed amount			
Code	ASCII	ESC	3	n
	Hex.	1B	33	n
	Decimal	27	51	n
Defined Region	$0 \leq n \leq 255$			
Initial Value	Line feed amount equivalent to approximately 4.23 mm (1/6 inch).			
Function	Sets the line space for one line to [n x basic calculated pitch].			
Details	<ul style="list-style-type: none"> <li>• Line spacing can be set independently for both the standard and page modes.</li> <li>• The basic calculated pitch is set by GSP (Set basic calculated pitch). Also, after setting the line space, it is not affected even if the basic calculated pitch is changed.</li> <li>• If the calculation results in fractions, the pitch is corrected to a minimal mechanical pitch and the rest is discarded.</li> <li>• In standard mode, the basic calculated pitch (y) for the vertical direction is used.</li> <li>• In page mode, the basic calculated pitch that is used according to the starting point varies.               <ol style="list-style-type: none"> <li>a. When the starting point is specified to be upper left or lower right by the ESC T command (Character print direction selection in page mode), the basic calculated pitch (x) for the horizontal direction is used.</li> <li>b. When the starting point is specified to be upper right or lower left by the ESC T command (Character print direction selection in page mode), the basic calculated pitch (y) for the horizontal direction is used.</li> </ol> </li> <li>• The maximum value that can be set for the line space is approximately 1,016mm (or 40 inches). Specifications that exceed the maximum value are rounded off to that value.</li> </ul>			
Reference	ESC 2, GS P			

**ESC = n**

Name                    Select peripheral device

Code                    ASCII    ESC    =    n  
                           Hex.      1B  3D    n  
                           Decimal  27  61    n

Defined Region     $0 \leq n \leq 255$

Initial Value        n = 1

Function             Selects the peripheral device for which the data is effective from the host computer.

Bit	Function	"0"	"1"
7	Undefined		
6	Undefined		
5	Undefined		
4	Undefined		
3	Undefined		
2	Undefined		
1	Undefined		
0	Printer	Invalid	Valid

Details                • If the printer is selected to be invalid, the printer discards all data from the next data until the printer is made valid again by this command. (This excludes DLEET, DLEENQ, DLEDC4.)

STAR                    • Even when the printer is not invalid, the printer specification of this command (n = 1) is processed.

**ESC ? n**

Name Delete download characters

Code	ASCII	ESC	?	n
	Hex.	1B	3F	n
	Decimal	27	63	n

Defined Region  $32 \leq n \leq 126$

Function Deletes the download characters to the specified character code.

- Details
- n specifies the character code to delete the defined pattern. After deleting, the printer prints the same pattern as the internal characters.
  - Deletes the specified code definition pattern of the character code selected by ESCM and ESC !.
  - This command is ignored when the specified character code is undefined.

Reference ESC &, ESC %

## ESC @

Name	Initialize printer									
Code	<table border="0"> <tr> <td>ASCII</td> <td>ESC</td> <td>@</td> </tr> <tr> <td>Hex.</td> <td>1B</td> <td>40</td> </tr> <tr> <td>Decimal</td> <td>27</td> <td>64</td> </tr> </table>	ASCII	ESC	@	Hex.	1B	40	Decimal	27	64
ASCII	ESC	@								
Hex.	1B	40								
Decimal	27	64								
Function	Clears data from the print buffer and sets the printer to its default settings.									
Details	<ul style="list-style-type: none"> <li>• DIP switch settings are not reload.</li> <li>• Data in the reception buffer is maintained.</li> <li>• Macro definition information is maintained.</li> <li>• NV bit image definition information is maintained.</li> <li>• User NV memory data is maintained.</li> <li>• When page mode is selected, this recovers to standard mode.</li> </ul>									
STAR	<p>The printer is initialized by this command under the following conditions.</p> <ul style="list-style-type: none"> <li>• Selection of an effective paper out detector for paper out signal output (ESC c 3n)</li> <li>• Select an effective paper out detector for printing stop (ESC c 4n)</li> </ul>									



## ESC D n1 ... nk NUL

Name	Set horizontal tab position
Code	ASCII    ESC    D    n1...nk NUL
	Hex.      1B    44    n1...nk NUL
	Decimal    27    68    n1...nk NUL
Defined Region	$1 \leq n \leq 255$
	$0 \leq k \leq 32$
Initial Value	<ul style="list-style-type: none"> <li>• Every 8 characters when using Font A (12 x 24) and the setting for the right spacing of characters is 0. (9<sup>th</sup> column, 17<sup>th</sup> column, 25<sup>th</sup> column ...)</li> </ul>
Function	Sets horizontal tab position
	<ul style="list-style-type: none"> <li>• n specifies the column number for setting a horizontal tab position from the left margin or the beginning of the line.</li> <li>• k indicates the number of horizontal tab positions to be set.</li> </ul>
Details	<ul style="list-style-type: none"> <li>• The horizontal tab position is a value of from the left margin or the beginning of the line [n x character width].</li> </ul> <p>Character width is the horizontal width including ESC SP (character right space). If the character horizontal direction magnification ratio is more than 2, the character width is also enlarged accordingly.</p> <ul style="list-style-type: none"> <li>• This command cancels the previous set horizontal tab settings.</li> <li>• When horizontal tab position setting n = 8, the next print position is moved to column 9 by executing HT (horizontal tab).</li> <li>• Up to 32 tab positions (k = 32) can be set. Subsequent data exceeding that is processed as normal data.</li> <li>• &lt;n&gt; for specifying horizontal position settings is input in ascending order. It is quit using &lt;00&gt;H. If &lt;n&gt; is less than or equal to the preceding value &lt;n&gt;, horizontal tab setting is completed and subsequent data is processed as normal data.</li> <li>• ESC D NULL cancels all horizontal tab positions.</li> <li>• Previously specified horizontal tab positions do not change, even if the character width changes after setting the horizontal tab position.</li> </ul> <p>The character width is stored for standard and page modes.</p>
	STAR
Reference	HT

**ESC E n**

Name	Specify/cancel emphasized characters			
Code	ASCII	ESC	E	n
	Hex.	1B	45	n
	Decimal	27	69	n
Defined Region	$0 \leq n \leq 255$			
Initial Value	n = 0			
Function	Specifies or cancels emphasized characters.			
	• Cancels emphasized characters when n = <*****0>B.			
	• Specifies emphasized characters when n = <*****1>B.			
Details	• n is effective only when it is the lowest bit.			
	• The setting of the last received command is effective even when emphasized printing is executed by the ESC! (Batch specify print mode) command.			
	• This command is enabled for ANK characters and Chinese characters.			
Reference	ESC !			

**ESC G n**

Name	Specify/cancel double printing			
Code	ASCII	ESC	G	n
	Hex.	1B	47	n
	Decimal	27	71	n
Defined Region	$0 \leq n \leq 255$			
Initial Value	n = 0			
Function	Specifies or cancels double printing.			
	<ul style="list-style-type: none"> <li>• Cancels double printing when n = &lt;*****0&gt;B.</li> <li>• Specifies double printing when n = &lt;*****1&gt;B.</li> </ul>			
Details	<ul style="list-style-type: none"> <li>• n is effective only when it is the lowest bit.</li> <li>• This printer is not capable of double printing, so the print is the same as when using emphasized printing.</li> <li>• This command is enabled for ANK characters and Chinese characters.</li> </ul>			
Reference	ESC E			

**ESC J n**

Name	Print and Paper Feed
Code	ASCII    ESC    J    n
	Hex.        1B   4A    n
	Decimal    27   74    n
Defined Region	$0 \leq n \leq 255$
Function	Prints the data in the print buffer and feeds the paper [n x basic calculated pitch].
Details	<ul style="list-style-type: none"> <li>• Sets the print position to the beginning of the next line after execution.</li> <li>• The line spacing amount set by the following commands is not affected.               <ol style="list-style-type: none"> <li>a. ESC 2 (Default line feed amount)</li> <li>b. ESC 3 (Set line feed amount)</li> </ol> </li> <li>• The basic calculated pitch is set by GSP (Set basic calculated pitch).</li> <li>• If the calculation results in fractions, the pitch is corrected to a minimal mechanical pitch and the rest is discarded.</li> <li>• In standard mode, the basic calculated pitch (y) for the vertical direction is used.</li> <li>• In page mode, the basic calculated pitch that is used according to the starting point varies.               <ol style="list-style-type: none"> <li>a. When the starting point is specified to be upper left or lower right by the ESC T command (Character print direction selection in page mode), the basic calculated pitch (x) for the horizontal direction is used.</li> <li>b. When the starting point is specified to be upper right or lower left by the ESC T command (Character print direction selection in page mode), the basic calculated pitch (y) for the horizontal direction is used.</li> </ol> </li> <li>• Paper is fed approximately 1016 mm if the [n x basic calculated pitch] exceeds approximately 1016 mm (40 inches).</li> </ul>
STAR	<ul style="list-style-type: none"> <li>• When the setting for the line feed amount is smaller than the print data height in standard mode:               <ol style="list-style-type: none"> <li>a. If there is no print data, a line feed operation is executed according to the line feed amount.</li> <li>b. If there is print data, a line feed operation is executed for the height of the print data.</li> </ol> </li> </ul>
Reference	GS P

## ESC L

Name	Select page mode
Code	ASCII    ESC    L Hex.      1B   4C Decimal    27   76
Function	Switches from standard mode to page mode.
Details	<ul style="list-style-type: none"> <li>• Enabled only when input with the top of line.</li> <li>• Invalid when input by page mode.</li> <li>• Returns to standard mode after the following commands are issued.             <ol style="list-style-type: none"> <li>a. FF (Print and recover to page mode)</li> <li>b. ESC S (Select standard mode)</li> </ol> </li> <li>• Character expansion position has the starting point specified by ESC T (Character print direction selection in page mode) in the printing region designated by the ESC W (Set print region in the page mode) command.</li> <li>• This command switches the settings for the following commands the values of which can be set independently in standard mode and page mode to those for page mode             <ol style="list-style-type: none"> <li>a. Set space amount:ESC SP, FS S</li> <li>b. Set line feed amount:ESC 2, ESC 3</li> </ol> </li> <li>• The following commands are enabled only when in page mode.             <ol style="list-style-type: none"> <li>a. ESC V:      Specify/cancel character 90 degree clockwise rotation</li> <li>b. ESC a:      Position alignment</li> <li>c. ESC {:      Specify/cancel upside-down printing</li> <li>d. GS L:      Set left margin</li> <li>e. GS W:      Set print region width</li> </ol> </li> <li>• The following command is ignored in page mode.             <ol style="list-style-type: none"> <li>a. GS (A:      Test print</li> </ol> </li> <li>• The following commands are invalid in page mode.             <ol style="list-style-type: none"> <li>a. FS p:      Print NV bit image</li> <li>b. FS q:      Define NV bit image</li> <li>c. FS g1:     Write data to user NV memory</li> <li>d. GS v0:     Print raster bit images</li> <li>e. GS ( L m fn (fn = 69):    Print NV graphics</li> <li>f. GS ( 8 m fn (fn = 69):    Print NV graphics</li> </ol> </li> <li>• Recover to standard mode using ESC@ (initialize printer).</li> </ul>
Reference	FF, CAN, ESC FF, ESC S, ESC T, ESC W, GS \$, GS \ See section 2. Explanations of the Page Mode for details.

**ESC M n**

Name            Select character font

Code            ASCII    ESC    M    n

                  Hex.      1B   4D    n

                  Decimal  27   77    n

Defined Region n = 0, 1, 48, 49

Function        Selects character font.

n	Function
0,48	Selects Font A (12 x 24).
1,49	Selects Font B (9 x 17).

Details            • It is possible to select the character font using ESC! (Batch specify Chinese character print mode), but the last command received is effective.

STAR              • The following are the font configurations on STAR printers.

Character Fonts	Horizontal Dots x Vertical Dots
Font A	12 x 24 Dots
Font B	9 x 24 Dots

Reference        ESC !

**ESC R n**

Name	Select international characters
Code	ASCII    ESC    R    n Hex.        1B   52    n Decimal    27   82    n
Defined Region	Spec. A: $0 \leq n \leq 13$ Spec. B: $0 \leq n \leq 17$
Initial Value	n = 0
Function	Selects the character set for the country listed below. Spec. A:

n	Country
0	America
1	France
2	Germany
3	UK
4	Denmark I
5	Sweden
6	Italy
7	Spain I
8	Japan
9	Norway
10	Denmark II
11	Spain II
12	Latin America
13	Korea

Spec. B:

n	International character set
0	America
1	France
2	Germany
3	UK
4	Denmark I
5	Sweden
6	Italy
7	Spain I
8	Japan
9	Norway
10	Denmark II
11	Spain II
12	Latin America
13	Korea
14	Slovenia / Croatia
15	China
16	Vietnam
17	Arabia

## ESC S

Name	Select standard mode									
Code	<table border="0"> <tr> <td>ASCII</td> <td>ESC</td> <td>S</td> </tr> <tr> <td>Hex.</td> <td>1B</td> <td>53</td> </tr> <tr> <td>Decimal</td> <td>27</td> <td>83</td> </tr> </table>	ASCII	ESC	S	Hex.	1B	53	Decimal	27	83
ASCII	ESC	S								
Hex.	1B	53								
Decimal	27	83								
Function	Switches from page mode to standard mode.									
Details	<ul style="list-style-type: none"> <li>• Valid only when input by page mode.</li> <li>• All buffer data in page mode is deleted.</li> <li>• Sets the print position to the beginning of the next line after execution.</li> <li>• The print area set by ESCW (Set print region in page mode) is reset to the default setting.</li> <li>• This command switches the settings for the following commands the values of which can be set independently in standard mode and page mode to those for standard mode             <ul style="list-style-type: none"> <li>a. ESC SP: Set character right space amount</li> <li>b. FS S: Set Chinese character space amount</li> <li>c. ESC 2: Set default line spacing</li> <li>d. ESC 3: Set line feed amount</li> </ul> </li> <li>• The following commands are effective only when in standard mode.             <ul style="list-style-type: none"> <li>a. ESC W:Set print region in page mode</li> <li>b. ESC T: Select character print direction in page mode</li> </ul> </li> <li>• The following commands are ignored in standard mode.             <ul style="list-style-type: none"> <li>a. GS S: Specify absolute position for character vertical direction in page mode</li> <li>b. GS \: Specify relative position for character vertical direction in page mode</li> </ul> </li> <li>• Standard mode is selected when the power is turned on, the printer is reset or initialized (ESC @).</li> </ul>									
Reference	FF, ESC FF, ESC L									



**ESC T n**

Name	Select character print direction in page mode			
Code	ASCII	ESC	T	n
	Hex.	1B	54	n
	Decimal	27	84	n
Defined Region	$0 \leq n \leq 3, 48 \leq n \leq 51$			
Initial Value	n = 0			
Function	Selects the character printing direction and starting point in page mode.			

n	Print Direction	Starting Point
0,48	Left to Right	Upper Left (A in the figure below)
1,49	Bottom to Top	Lower Left (B in the figure below)
2,50	Right to Left	Lower Right (C in the Figure below)
3,51	Top to Bottom	Upper Right (D in the figure below)

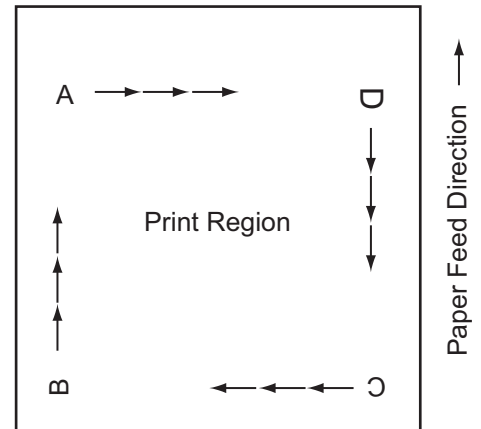
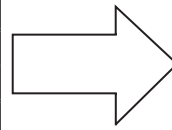

Details	<ul style="list-style-type: none"> <li>Executes only a printer internal flag operation when this command is input in standard mode. The command does not affect printing in standard mode.</li> <li>The character expansion starting point is in the print region specified by ESC W (Set print region in page mode).</li> <li>The basic calculated pitch (x or y) used with the following commands differs according to the starting point.                             <ol style="list-style-type: none"> <li>If the starting point is upper left or lower right (feeds paper and expands characters in the vertical direction)                                     <table border="0" style="margin-left: 20px;"> <tr> <td>Commands using x:</td> <td>ESC SP, ESC \$, ESC \, FS S</td> </tr> <tr> <td>Commands using y:</td> <td>SC 3, ESC J, GS \$, GS \</td> </tr> </table> </li> <li>If the starting point is upper right or lower left                                     <table border="0" style="margin-left: 20px;"> <tr> <td>Commands using x:</td> <td>ESC 3, ESC J, GS \$, GS \</td> </tr> <tr> <td>Commands using y:</td> <td>ESC SP, ESC \$, ESC \, FS S</td> </tr> </table> </li> </ol> </li> </ul>	Commands using x:	ESC SP, ESC \$, ESC \, FS S	Commands using y:	SC 3, ESC J, GS \$, GS \	Commands using x:	ESC 3, ESC J, GS \$, GS \	Commands using y:	ESC SP, ESC \$, ESC \, FS S
	Commands using x:	ESC SP, ESC \$, ESC \, FS S							
Commands using y:	SC 3, ESC J, GS \$, GS \								
Commands using x:	ESC 3, ESC J, GS \$, GS \								
Commands using y:	ESC SP, ESC \$, ESC \, FS S								
Reference	ESC \$, ESC L, ESC W, ESC \, GS \$, GS P, GS \								

**ESC V n**

Name Specify/cancel character 90 degree clockwise rotation

Code ASCII ESC V n

Hex. 1B 56 n

Decimal 27 86 n

Defined Region  $0 \leq n \leq 1, 48 \leq n \leq 49$

Initial Value  $n = 0$

Function Specifies or cancels character 90 degree clockwise rotation.

n	Function
0, 48	Cancels 90 degree clockwise rotation
1, 49	Specifies 90 degree clockwise rotation

Details

- Underlines are not applied to characters rotated 90 degrees clockwise even when ESC !, ESC - or FS - commands are given.
- If 90 degree clockwise rotation is specified, double-wide and double-tall commands in the 90 rotation mode enlarges characters in the opposite directions to double-wide and double-tall commands.
- This command only affects printing in standard mode.
- In page mode, this command is only effective for the setting.
- This command is effective for ANK and Chinese characters.

STAR

- Characters are rotated as shown below when printing 90 degree clockwise rotation characters.

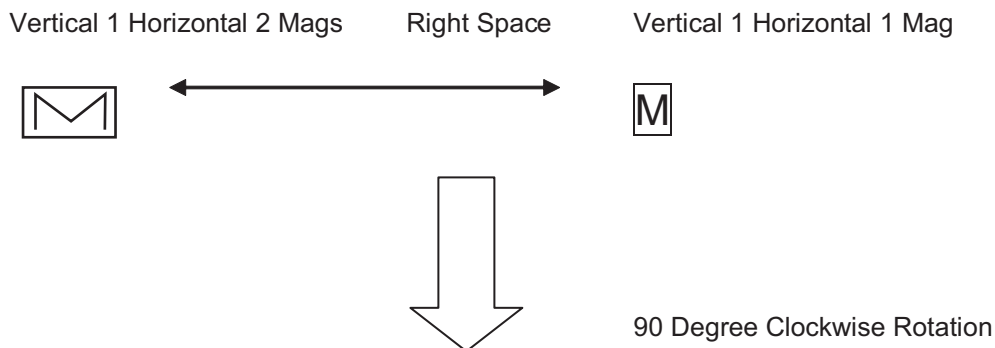

Reference ESC !, ESC -

## ESC W xL xH yL yH dxL dxH dyL dyH

Name	Set print region in page mode										
Code	ASCII	ESC	W	xL	xH	yL	yH	dxL	dxH	dyL	dyH
	Hex.	1B	57	xL	xH	yL	yH	dxL	dxH	dyL	dyH
	Decimal	27	87	xL	xH	yL	yH	dxL	dxH	dyL	dyH
Defined Region	$0 \leq xL, xH, yL, yH, dxL, dxH, dyL, dyH \leq 255$										
	However, this excludes $dxL = dxH = 0$ or $dyL = dyH = 0$										
Initial Value	$xL = xH = yL = yH = 0$										
	See Appendix-5 for details relating to dxL, dxH, dyL, dyH.										
Function	Sets the print region position and size.										
	• Horizontal direction starting point $[(xL + xH \times 256) \times \text{basic calculated pitch}]$										
	• Vertical direction starting point $[(yL + yH \times 256) \times \text{basic calculated pitch}]$										
	• Horizontal direction length $[(dxL + dxH \times 256) \text{ basic calculated pitch}]$										
	• Vertical direction length = $[(dyL + dyH \times 256) \text{ basic calculated pitch}]$										
Details	• In standard mode, the printer executes only internal flag operations with this command is input.										
	• If the horizontal direction starting point or vertical direction starting point is outside of the printable region, the command is stopped and normal printing commences from subsequent data.										
	• If the horizontal direction length or vertical direction length is 0, the command is stopped and normal printing commences from subsequent data.										
	• The character expansion starting point is the point specified by selecting the character printing direction (ESC T) in page mode in the print region.										
	• If (horizontal direction starting position + horizontal direction length) exceeds the printable region in the horizontal direction, the horizontal direction length is set to (horizontal direction printable region - horizontal direction starting point).										
	• If (vertical direction starting position + vertical direction length) exceeds the printable region in the vertical direction, the vertical direction length is set to (vertical direction printable region - vertical direction starting point).										
	• The basic calculated pitch is set by GSP (Set basic calculated pitch). Also, the set printing region is not changed even if the basic calculated pitch is changed after setting the print region.										
	• If the calculation results in fractions, the pitch is corrected to a minimal mechanical pitch and the rest is discarded.										
	• The basic calculated pitch (x) is used in the calculated pitch for the horizontal direction starting point and the length in the horizontal direction; and the basic calculated pitch (y) is used in the calculated pitch for the vertical direction starting point and the length in the vertical direction.										
	• The print region shown in the figure below when the horizontal direction starting is X; the vertical direction starting point is Y; the horizontal direction length is Dx; and the vertical direction length is Dy.										
• See Appendix-5 for details on print regions.											

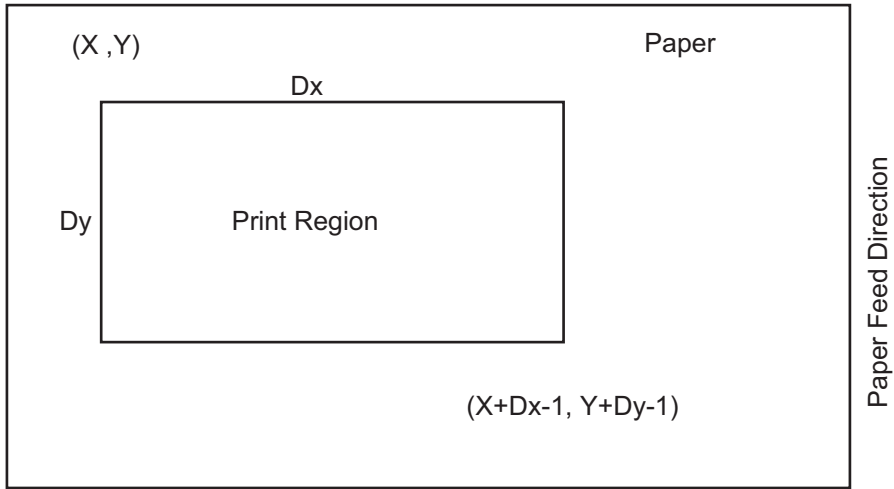

Reference      CAN, ESC L, ESC T, GSP, Appendix-5

**ESC \ nL nH**

Name	Specify relative position															
Code	<table border="0"> <tr> <td>ASCII</td> <td>ESC</td> <td>\</td> <td>nL</td> <td>nH</td> </tr> <tr> <td>Hex.</td> <td>1B</td> <td>5C</td> <td>nL</td> <td>nH</td> </tr> <tr> <td>Decimal</td> <td>27</td> <td>92</td> <td>nL</td> <td>nH</td> </tr> </table>	ASCII	ESC	\	nL	nH	Hex.	1B	5C	nL	nH	Decimal	27	92	nL	nH
ASCII	ESC	\	nL	nH												
Hex.	1B	5C	nL	nH												
Decimal	27	92	nL	nH												
Defined Region	$0 \leq nL \leq 255$ $0 \leq nH \leq 255$															
Function	<ul style="list-style-type: none"> <li>Specifies the next print starting position with a relative position based on the current position. This sets the position from the current position to <math>[(nL + nH \times 256) \times \text{basic calculated pitch}]</math> for the next print starting position.</li> </ul>															
Details	<ul style="list-style-type: none"> <li>Specifications exceeding the print range are ignored.</li> <li>If the right direction of the current position is specified for the character direction, specify a positive number; if the left direction is specified, a negative number is used.</li> <li>Negative numbers is represented by the complement of 65536. For example, when moving in the left direction n pitches, use:  <math>nL + nH \times 256 = 65536 - N</math></li> <li>The basic calculated pitch is set by GSP (basic calculated pitch setting).</li> <li>If there are fractions in the result, correct to the minimum mechanical pitch and discard.</li> <li>Use the basic calculated pitch (x) for the horizontal direction in standard mode.</li> <li>The following operations occur according to the starting point in page mode.             <ol style="list-style-type: none"> <li>If the starting point is set to upper left or lower right by the ESC T (Select character print direction in page mode) command, specify the relative position of the vertical direction in the paper feed. Use the basic calculated pitch (x) for the horizontal direction at this time.</li> <li>If the starting point is set to upper right or lower left by the ESC T (Select character print direction in page mode) command, move the print position in the paper feed direction. Use the basic calculated pitch (y) for the horizontal direction at this time.</li> </ol> </li> </ul>															
Reference	ESC \$, GS P															

**ESC a n**

Name	Position alignment			
Code	ASCII	ESC	a	n
	Hex.	1B	61	n
	Decimal	27	97	n
Defined Region	$0 \leq n \leq 2, 48 \leq n \leq 50$			
Initial Value	n = 0			
Function	Aligns all print data in one line to a specified position.			

n	Position
0, 48	Left alignment
1, 49	Center
2, 50	Right alignment

- Details
- This command is effective only when input at the top of the line when standard mode is being used.
  - This command does not have any effect in page mode. In page mode, this command is only effective for the setting.
  - Specifies the alignment position in the printing region that has been set.
  - Portions skipped using the following commands are also targeted for position alignment.
    - a. HT : Horizontal tab
    - b. ESC \$ : Specify absolute position
    - c. ESC \ : Specify relative position

[Ex.]

<b>Left alignment</b>	<b>Center</b>	<b>Right alignment</b>
ABC ABCD ABCDE	ABC ABCD ABCDE	ABC ABCD ABCDE

**ESC c 3 n**

Name	Select paper out sensor to enable at paper out signal output
Code	ASCII    ESC    c    3    n Hex.        1B   63   33   n Decimal    27   99   51   n
Defined Region	$0 \leq n \leq 15$
Initial Value	Spec. A: n = 15 Spec. B: n = 0
Function	Selects paper out detector that outputs a paper out signal when paper has run out.

Spec. B:

Bit	Function	"0"	"1"
7	Undefined	--	--
6	Undefined	--	--
5	Undefined	--	--
4	Undefined	--	--
3	Undefined	--	--
2	Undefined	--	--
1	Paper roll near end detector	Invalid	Valid
0	Paper roll near end detector	Invalid	Valid

Details	<ul style="list-style-type: none"> <li>• It is possible to select a multiple of detectors for signal output at the same time. If any of the detectors detects the end of the paper, the paper end signal is output.</li> <li>• This command is only effective when using a parallel interface. It is ignored when using a serial interface.</li> <li>• The detector switches when this command is executed so there may be some delay from reception of this command until switching to the paper out signal, depending on the status of the reception buffer.</li> <li>• If either bit 0 or bit 1 is set to 1, select the paper roll near end detector as the paper out detector for paper out signal output.</li> <li>• If either bit 2 or bit 3 is set to 1, select the paper roll end detector as the paper out detector for paper out signal output.</li> <li>• If all detectors are invalid, the paper out signal is constantly output as having paper.</li> </ul>
---------	--

**ESC c 4 n**

Name Select paper out sensor to enable at printing stop

Code ASCII ESC c 4 n  
 Hex. 1B 63 34 n  
 Decimal 27 99 52 n

Defined Region  $0 \leq n \leq 255$

Initial Value n = 0

Function Selects the paper out detector to stop printing when paper has run out.

Bit	Function	"0"	"1"
7	Undefined	--	--
6	Undefined	--	--
5	Undefined	--	--
4	Undefined	--	--
3	Undefined	--	--
2	Undefined	--	--
1	Paper roll near end detector	Invalid	Valid
0	Paper roll near end detector	Invalid	Valid

- Details
- To stop printing, the printer stops after printing the current line and feeding paper.
  - The printer goes offline when printing is stopped.
  - If either bit 0 or bit 1 is set to 1, select the paper roll near end detector as the paper out detector effective to stop printing.



**ESC c 5 n**

Name	Enable/disable panel switches				
Code	ASCII	ESC	c	5	n
	Hex.	1B	63	35	n
	Decimal	27	99	53	n
Defined Region	$0 \leq n \leq 255$				
Initial Value	n = 0				
Function	Toggles the panel switches between enabled and disabled. <ul style="list-style-type: none"> <li>• Enables panel switches when n = &lt;*****0&gt;B.</li> <li>• Disables panel switches when n = &lt;*****1&gt;B.</li> </ul>				
Details	<ul style="list-style-type: none"> <li>• n is effective only when it is the lowest bit.</li> <li>• When disabled, all panel switches are disabled.</li> <li>• The paper feed switch is enabled regardless of this command if waiting for the switch while executing a macro. However, there is no paper feed.</li> </ul>				
STAR	<ul style="list-style-type: none"> <li>• Switches are disabled even if the panel switches are enabled using this command for the following cases.             <ol style="list-style-type: none"> <li>a. When paper out errors occur</li> <li>b. When cover open errors occur</li> </ol> </li> <li>• Use the ESC @ command to reset the panel switches disabled using this command.</li> </ul>				

**ESC d n**

Name	Print and feed paper n lines
Code	ASCII    ESC    d    n
	Hex.        1B   64    n
	Decimal    27  100    n
Defined Region	$0 \leq n \leq 255$
Function	Prints the data in the print buffer and performs a paper feed of n lines.
Details	<ul style="list-style-type: none"> <li>• Sets the print position to the beginning of the next line after printing.</li> <li>• Line feeds set by the following commands are not affected.               <ol style="list-style-type: none"> <li>a. ESC 2:     Set default line spacing</li> <li>b. ESC 3:     Set line feed amount</li> </ol> </li> <li>• Paper is fed approximately 1016 mm (40 inches) if the [n x line feed amount] exceeds approximately 1016 mm (40 inches) .</li> </ul>
	STAR
Reference	ESC 2, ESC 3

**ESC p m t1 t2**

Name Specify pulse

Code ASCII ESC p m t1 t2  
 Hex. 1B 70 m t1 t2  
 Decimal 27 112 m t1 t2

Defined Region  $0 \leq m \leq 1, 48 \leq m \leq 49$   
 $0 \leq t1 \leq 255$   
 $0 \leq t2 \leq 255$

Function This outputs a signal specified by t1 and t2 to the connector pin specified by m.

m	Connector Pin
0, 48	Drawer kick connector pin #2
1, 49	Drawer kick connector pin #5

Details Drawer kick on time is set to  $t1 \times 2$  ms; off time is set to  $t2 \times 2$  ms.

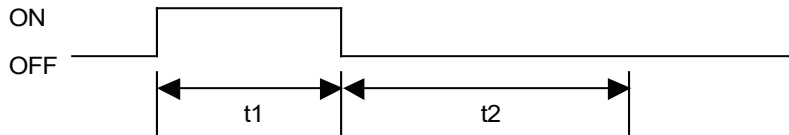

When  $t1 > t2$ , the value of  $t2$  is processed as  $t2 = t1$ .

Reference DLE DC4

**ESC t n**

Name Select character code table

Code ASCII ESC t n

Hex. 1B 74 n

Decimal 27 116 n

Defined Region Spec. A:  $0 \leq n \leq 5, 16 \leq n \leq 19, n = 255$   
 Spec. B:  $0 \leq n \leq 5, 16 \leq n \leq 26, n = 255$

Initial Value n = 0

Function Select page n of the character code table.

Spec. A:

n	Character Type
0	PC437 (USA: Standard Europe)
1	Katakana
2	PC850(Multilingual)
3	PC860(Portuguese)
4	PC863(Canadian-French)
5	PC865(Nordic)
16	WPC1252
17	PC866 (Cyrillic #2)
18	PC852 (Latin2)
19	PC858
255	Blank page

Spec. B:

n	Character Type
0	PC437 (USA: Standard Europe)
1	Katakana
2	PC850(Multilingual)
3	PC860(Portuguese)
4	PC863(Canadian-French)
5	PC865(Nordic)
16	WPC1252
17	PC866 (Cyrillic #2)
18	PC852 (Latin2)
19	PC858
20	Thai Character Code 42 [Thai]
21	Thai Character Code 11 [Thai]
22	Thai Character Code 13 [Thai]
23	Thai Character Code 14 [Thai]
24	Thai Character Code 16 [Thai]
25	Thai Character Code 17 [Thai]
26	Thai Character Code 18 [Thai]
255	Blank page

Reference ESC GS t

**ESC { n**

Name Specify/cancel upside-down printing

Code ASCII ESC { n  
 Hex. 1B 7B n  
 Decimal 27 123 n

Defined Region  $0 \leq n \leq 255$

Initial Value  $n = 0$

Function Specifies or cancels upside-down printing.  
 • Cancels upside-down printing when  $n = \langle \text{*****}0 \rangle H$ .  
 • Specifies upside-down printing when  $n = \langle \text{*****}1 \rangle H$ .

Details  
 • n is effective only when it is the lowest bit.  
 • This command is effective only when input at the top of the line when standard mode is being used.  
 • This command has no affect in page mode. In page mode, this command is only effective for the setting.  
 • Upside-down printing rotates line data 180 degrees.

STAR  
 • The characters that are printed in upside-down printing are reversed, but the order of the lines that are printed are not in reverse.

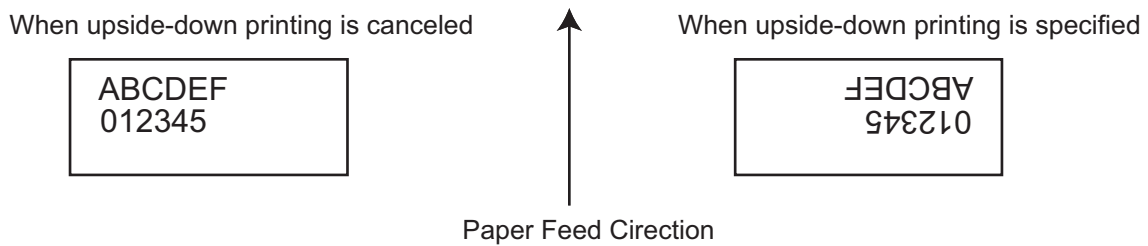

- Upside-down printing is enabled for the following images.
  - a. ESC \* : Specify bit image mode
  - b. GS /: Print download bit images
  - c. FS P: Print NV bit image mode

**FS g 1 m a1 a2 a3 a4 nL nH d1 ... dk**

Name	Write data to user NV memory											
Code	ASCII	FS	g	1	m	a1	a2	a3	a4	nL	nH	d1...dk
	Hex.	1C	67	31	m	a1	a2	a3	a4	nL	nH	d1...dk
	Decimal	28	103	49	m	a1	a2	a3	a4	nL	nH	d1...dk
Defined Region	m = 0 $0 \leq \{a1 + (a2 \times 256) + (a3 \times 65536) + (a4 \times 16777216)\} \leq 1023$ $1 \leq \{nL + (nH \times 256)\} \leq 1024$ $32 \leq d \leq 255$ $k = \{nL + (nH \times 256)\}$											
Function	Stores data in the user NV memory. <ul style="list-style-type: none"> <li>• m is fixed at 0.</li> <li>• a1, a2, a3 and a4 specify the data storage addresses <math>\{a1 + (a2 \times 256) + (a3 \times 65536) + (a4 \times 16777216)\}</math>.</li> <li>• nL and nH specify the storage data count in bytes of <math>\{nL + (nH \times 256)\}</math>.</li> <li>• d specifies the stored data.</li> </ul>											
Details	<ul style="list-style-type: none"> <li>• The user NV memory is a storage region dedicated for character data that is ensured on a non-volatile memory.</li> <li>• This command is effective only when input at the top of the line when standard mode is being used.</li> <li>• When in page mode, this command is invalid.</li> <li>• When processing this command while defining a macro, the macro definition is terminated and the command commences with processing.</li> <li>• This command is ignored and subsequent data is processed as normal data if the argument (m), storage starting address (a1, a2, a3, a4), and the storage data count (nL, nH) are out of the definition, or if <math>\{[the\ storage\ starting\ address\ (a1, a2, a3, a4) + storage\ data\ count\ (nL, nH)]\} \geq 1024</math>.</li> <li>• This command is completed when the storage data (d) out of the definition is processed, and subsequent data is processed as normal data. At this time, data that has already been processed is stored in memory.</li> <li>• The data storage process executes an overwrite. Therefore, data that is already stored in the region is erased.</li> <li>• A memory or gate array R/W error occurs when a writing error occurs.</li> <li>• Data in the user NV memory can be read using FS g 2 (Read user NV memory data).</li> <li>• User NV memory data is not initialized with the following.             <ol style="list-style-type: none"> <li>a. ESC@ :Initialize printer</li> <li>b. FS q: Define NV bit image</li> <li>c. When the printer is reset or the power is turned off</li> </ol> </li> </ul>											

Notes:	<ul style="list-style-type: none"><li>• There is the potential of damaging the non-volatile memory by overusing the command to write to that memory (FS g 1), so only use this command once a day to write to the non-volatile memory.</li><li>• The printer may enter a busy state while writing data to the non-volatile memory when using this command. While the printer is busy, the printer will stop receptions so data will not be received from the host (including real-time commands).</li></ul>
STAR	<ul style="list-style-type: none"><li>• STAR printers ignore this command. (It receives and discards the writing data of nL + nH x 256.)</li></ul>
Reference	FS g 2

**FS g 2 m a1 a2 a3 a4 nL nH**

Name	Read user NV memory data																
Code	ASCII	FS	g	2	m	a1	a2	a3	a4	nL	nH						
	Hex.	1C	67	32	m	a1	a2	a3	a4	nL	nH						
	Decimal	28	103	50	m	a1	a2	a3	a4	nL	nH						
Defined Region	m = 0																
	$0 \leq \{a1 + (a2 \times 256) + (a3 \times 65536) + (a4 \times 16777216)\} \leq 1023$ $1 \leq \{nL + (nH \times 256)\} \leq 80$																
Function	Sends the data in the user NV memory.																
	<ul style="list-style-type: none"> <li>• m is fixed at 0.</li> <li>• a1, a2, a3 and a4 specify the data sending starting addresses {a1 + (a2 x 256) + (a3 x 65536) + (a4 x 16777216)}.</li> <li>• nL and nH specify the transmissino data count in bytes of {nL + (nH x 256)}.</li> </ul>																
Details	<ul style="list-style-type: none"> <li>• The user NV memory is a storage region dedicated for character data that is ensured on a non-volatile memory.</li> <li>• This command is ignored and subsequent data is processed as normal data if the argument (m), storage starting address (a1, a2, a3, a4), and the storage data count (nL, nH) are out of the definition, or if [{the storage starting address (a1, a2, a3, a4) + storage data count (nL, nH)} <math>\geq 1024</math>].</li> <li>• The following process occur when preparations for transmitting data have been completed.               <ol style="list-style-type: none"> <li>1. Executes a READY to BUSY process If the printer is already in a BUSY state, it does nothing.</li> <li>2. Executes the [Header + Data + NUL] transmission</li> <li>3. Executes a BUSY to READY process If the printer is already in a BUSY state for some other reason, it does nothing.</li> </ol> </li> <li>• The configuration for the [Header + Data + NUL] is below.               <table border="0" style="margin-left: 20px;"> <tr> <td>Header:</td> <td>Hex. = 5FH/Decimal = 95 (1 byte)</td> </tr> <tr> <td>Data:</td> <td>User NV memory data (nL + (nH x 256) bytes)</td> </tr> <tr> <td>NUL:</td> <td>Hex. = 00H/Decimal = 0 (1 byte)</td> </tr> </table> </li> <li>• When DTR/DSR control is selected, after verifying that the host can receive data when transmitting the Header, all code are transmitted consecutively. If the host is not able to receive data, the printer will wait until it is ready.</li> <li>• When XON/XOFF control is selected, all code are transmitted consecutively without verifying whether the host can receive data. Always send data consecutively, except for the XOFF code.</li> <li>• With parallel interfaces, the transmission data buffer (excluding ASB status and the buffer that store all transmission data) is 99 bytes. Data that exceeds 99 bytes is discarded.</li> <li>• It is possible to write to the user NV memory using FS g 1.</li> <li>• There is the possibility of delays between the reception of this command and the storage of data depending on the reception buffer status.</li> </ul>											Header:	Hex. = 5FH/Decimal = 95 (1 byte)	Data:	User NV memory data (nL + (nH x 256) bytes)	NUL:	Hex. = 00H/Decimal = 0 (1 byte)
	Header:	Hex. = 5FH/Decimal = 95 (1 byte)															
Data:	User NV memory data (nL + (nH x 256) bytes)																
NUL:	Hex. = 00H/Decimal = 0 (1 byte)																



Notes:	<ul style="list-style-type: none"><li>• The printer transmits all data after starting transmission of the header without confirming whether the host computer can receive data. Therefore, when using this command, the host reception buffer size should be set to (transmission data + 2) to ensure that reception is not lost.</li><li>• Real-time command (DLE expansion command) is ignored while transmitting data. Also, ASB status is not transmitted while transmitting data even when the ASB function is enabled. Therefore, status changes in the printer while transmitting data are not known. The operator should be aware of this.</li></ul>
STAR	<ul style="list-style-type: none"><li>• STAR printers ignore this command. (They receive and discard FS g 2 m a1 a2 a3 a4 nL nH.)</li></ul>
Reference	FS g 1

## FS p n m

Name	Print NV bit image				
Code	ASCII	FS	p	n	m
	Hex.	1C	70	n	m
	Decimal	28	112	n	m

Defined Region  $1 \leq n \leq 255$   
 $0 \leq m \leq 3, 48 \leq m \leq 51$

Function Prints NV bit image n using mode m.

m	Mode	Density of Vertical Direction Dots	Density of Horizontal Direction Dots
0, 48	Normal Mode	180 DPI	180 DPI
1, 49	Double-wide Mode	180 DPI	90 DPI
2, 50	Double-tall Mode	90 DPI	180 DPI
3, 51	Quadruple Mode	90 DPI	90 DPI

- n specifies the NV bit image number.
  - m specifies the bit-image mode.
- Details
- NV bit image is a bit image defined in non-volatile memory by FS q and printed by this command.
  - This command is ignored when the specified NV bit image n is undefined.
  - This command is effective only when no data exists in the print buffer in standard mode. If data exists, 2 bytes are ignored.
  - When in page mode, this command is disabled.
  - Excluding upside-down printing, print modes (emphasized printing, double printing, underlines, character sizes, black/white inverted printing and 90 degree clockwise rotation) are unaffected.
  - If bit image specification is of a size that exceeds the print region, the data in the print region is targeted for printing, but the excessive data is not printed.
  - This command feeds dots (for the height n of the NV bit image) in normal and double-width modes, and (for the height of the NV bit image n x 2) in double-height and quadruple modes, regardless of the line spacing specified by ESC 2 (Set default line spacing) or ESC 3 (Set line feed amount).
  - After printing the bit image, this command sets the print position to the top of the line and processes the subsequent data as normal data.
- STAR
- Dot density (when the STAR printer head = 203 DPI) on STAR printers.

m	Mode	Density of Vertical Direction Dots	Density of Horizontal Direction Dots
0, 48	Normal Mode	203 DPI	203 DPI
1, 49	Double-wide Mode	203 DPI	101 DPI
2, 50	Double-tall Mode	101 DPI	203 DPI
3, 51	Quadruple Mode	101 DPI	101 DPI

- The NV bit image data defined by "GS ( L <fn=67>, GS ( 8 <fn=67>" is printable by this command.
- See Appendix-11 for setting details.
- Related Commands ESC \*, FS q, GS \, GS v 0
- Reference Appendix -11

**FS q n [xL xH yL yH d1...dk] 1... [xL xH yL yH d1...dk] n**

Name Define NV bit image

Code	ASCII	FS	q	n	[xL xH yL yH d1...dk]1 ...	[xL xH yL yH d1...dk] n
	Hex.	1C	71	n	[xL xH yL yH d1...dk]1 ...	[xL xH yL yH d1...dk] n
	Decimal	28	113	n	[xL xH yL yH d1...dk]1 ...	[xL xH yL yH d1...dk] n

Defined Region  $1 \leq n \leq 255$   
 $0 \leq xL \leq 255$   
 $0 \leq xH \leq 3$  However,  $1 \leq (xL+xH \times 256) \leq 1023$   
 $0 \leq yL \leq 255$   
 $0 \leq yH \leq 1$  However,  $1 \leq (yL+yH \times 256) \leq 288$   
 $0 \leq d \leq 255$   
 $k = (xL+xH \times 256) \times (yL+yH \times 256) \times 8$   
 Total defined data area = 2 M bytes (256 K bytes)

Function Defines the specified NV bit image.

- n specifies the number of NV bit images to define.
- xL and xH specify the horizontal direction for one NV bit image  $(xL + xH \times 256) \times 8$  dots.
- yL and yH specify the vertical direction for one NV bit image  $(yL + yH \times 256) \times 8$  dots.

Details

- This command erases all previously defined NV bit images. The printer cannot redefine only one of several data definitions that had been defined before. Therefore, all data must be resent.
- Mechanical operations (such as initializing the position of the print head when the cover is open, feeding paper using a switch) cannot be executed from the time this command commences its process until a hardware reset is completed.
- NV bit image is a bit image defined by this command in non-volatile memory and is printed by the FS p (Print NV bit image) command.
- This command is effective only when processed at the top of the line when standard mode is being used.
- When in page mode, this command is disabled.
- This command is effective when 7 bytes of FS to yH of the command are processed normally.
- When the amount of data exceeds the capacity left in the range defined by xL, xH, yL, yH, the printer processes an argument that is out of the defined range.
- This command is invalid when processing an argument that is out of the defined range with the initial NV bit image data.
- The printer terminates processing of this command and starts writing data to the non-volatile memory if an argument out of the defined range is processed on the second and subsequent NV bit image data. This invalidates the NV bit image being defined (making it undefined), but the NV bit images prior to that are valid.
- d specifies defined data. Bits that correspond to the dots to print are 1, and the bits that correspond to the dots that are not printed are 0.
- An n number of NV bit images are defined in ascending order from 01H. Therefore, The first data of [xLxHyLyHd1...dk] is an NV bit image of the number 01H. The final data of [xLxHyLyHd1...dk] is the NV bit image of the number n.  
 This matches with the NV bit image number that is specified for NV bit image printing (by FS p).

- See the printer's product specifications manual for details on NV memory capacity.
- One NV bit image definition data is configured by [xL xH yL yH d1...dk]. Therefore, if defining only one NV bit image data, n = 1. The data of [xL xH yL yH d1...dk] is processed only once. This uses ([data: (xL + xH x 256) x (yL + yH x 256) x 8] + [Data: 4]) of non-volatile memory.
- The maximum region for NV bit image definition varies according to the printer model. Several NV bit images can be defined, but NV bit image data that exceeds the maximum definition region with a total capacity of (data bit image data + header) cannot be defined.
- The printer is in a BUSY state just prior to writing to the non-volatile memory. The printer will be in a BUSY state prior to writing data regardless of the conditions for a BUSY state.
- The sending of ASB status and detection of status are not possible while processing this command even when the ASB function is specified.
- When processing this command while defining a macro, the macro definition is terminated and the command commences with processing.
- NV bit images that have been defined are not initialized by the ESC @ (Initialize printer), a reset or by turning off the printer's power.
- This command only defines the NV bit image, but it does not print it. To print an NV bit image, use FS p (Print NV bit image).

**Notes:**

- There is the potential of damaging the non-volatile memory by overusing the command, so only use this command once a day to write to the non-volatile memory.
- The printer executes a hardware reset just after writing to the non-volatile memory. Therefore, download characters and download bit images and macros are handled as being undefined and the reception buffer and print buffer are cleared. The printer returns all settings to their default status.
- The printer may enter a BUSY state while writing data to the non-volatile memory when using this command. While the printer is BUSY, the printer will stop receptions so data will not be received from the host (including real-time commands).

**STAR**

- Dot density (when the STAR printer head = 203 DPI) on STAR printers.

m	Mode	Density of Vertical Direction Dots	Density of Horizontal Direction Dots
0, 48	Normal Mode	203 DPI	203 DPI
1, 49	Double-wide Mode	203 DPI	101 DPI
2, 50	Double-tall Mode	101 DPI	203 DPI
3, 51	Quadruple Mode	101 DPI	101 DPI

**Related**

Commands FS p

When  $xL = 64$ ,  $xH = 0$ ,  $yL = 96$ ,  $yH = 0$

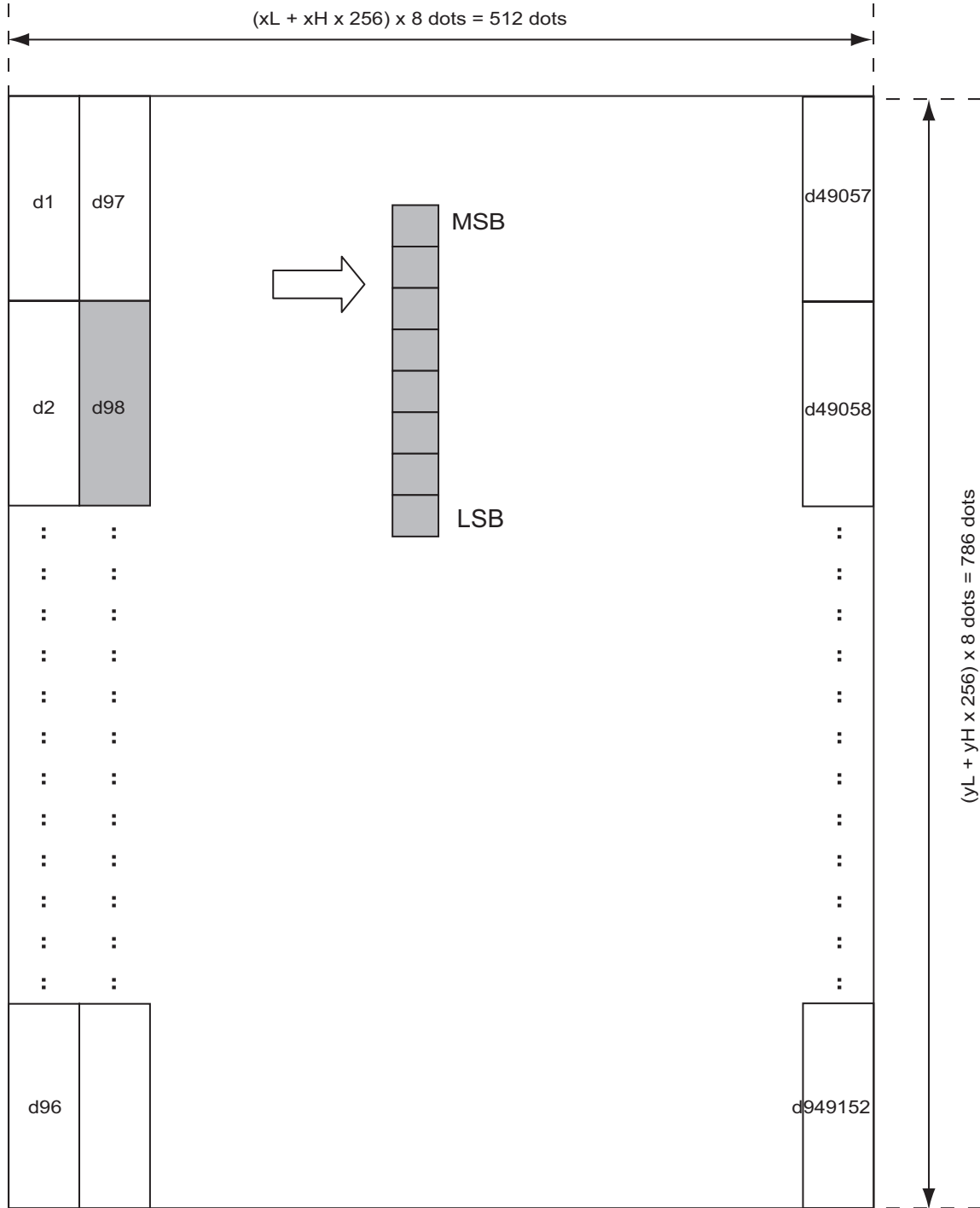

**GS!n**

Name Select character size

Code	ASCII	GS	!	n
	Hex.	1D	21	n
	Decimal	29	33	n

 Defined Region  $0 \leq n \leq 255$ 

 However,  $1 \leq$  vertical direction magnification ratio  $\leq 8$ ,  $1 \leq$  horizontal direction magnification ratio  $\leq 8$ 

 Initial Value  $n = 0$ 

Function Specifies the character size (magnification ratio in the vertical and horizontal directions).

Bit	Function	"0"	"1"
7	Specifies horizontal direction magnification ratio	(See table below)	
6			
5			
4			
3	Specifies vertical direction magnification ratio	(See table below)	
2			
1			
0			

&lt;Horizontal Direction Magnification Ratio Specification&gt;

&lt;Vertical Direction Magnification Ratio Specification&gt;

Bit-7	Bit-6	Bit-5	Bit-4	Hor. Dir. Mag. Ratio
0	0	0	0	1
0	0	0	1	2
0	0	1	0	3
0	0	1	1	4
0	1	0	0	5
0	1	0	1	6
0	1	1	0	7
0	1	1	1	8
1	0	0	0	Undefined
1	0	0	1	Undefined
1	0	1	0	Undefined
1	0	1	1	Undefined
1	1	0	0	Undefined
1	1	0	1	Undefined
1	1	1	0	Undefined
1	1	1	1	Undefined

Bit-3	Bit-2	Bit-1	Bit-0	Hor. Dir. Mag. Ratio
0	0	0	0	1
0	0	0	1	2
0	0	1	0	3
0	0	1	1	4
0	1	0	0	5
0	1	0	1	6
0	1	1	0	7
0	1	1	1	8
1	0	0	0	Undefined
1	0	0	1	Undefined
1	0	1	0	Undefined
1	0	1	1	Undefined
1	1	0	0	Undefined
1	1	0	1	Undefined
1	1	1	0	Undefined
1	1	1	1	Undefined

## Details

- This command is effective for all characters (ANK and Chinese characters), excluding HRI characters.
- If the vertical and horizontal magnification ratios are outside the defined range, this command is ignored.
- In standard mode, the vertical direction is the paper feed direction; the horizontal direction traverses the paper feed direction. Therefore, when character orientation changes in 90 degree clockwise rotation mode, the relationship between vertical and horizontal directions is reversed.
- In page mode, vertical and horizontal directions are based on the character orientation.
- The base line for characters is the same when there are characters having different vertical direction ratios in the same line.
- The ESC ! (Batch specify print mode) command can also turn double-width and double-height modes on or off, but the setting of the last received command is effective.

## Reference

ESC !

**GS \$ nL nH**

Name	Specify absolute position for character vertical direction in page mode															
Code	<table border="0"> <tr> <td>ASCII</td> <td>GS</td> <td>\$</td> <td>nL</td> <td>nH</td> </tr> <tr> <td>Hex.</td> <td>1D</td> <td>24</td> <td>nL</td> <td>nH</td> </tr> <tr> <td>Decimal</td> <td>29</td> <td>36</td> <td>nL</td> <td>nH</td> </tr> </table>	ASCII	GS	\$	nL	nH	Hex.	1D	24	nL	nH	Decimal	29	36	nL	nH
ASCII	GS	\$	nL	nH												
Hex.	1D	24	nL	nH												
Decimal	29	36	nL	nH												
Defined Region	$0 \leq nL \leq 255, 0 \leq nH \leq 255$															
Function	Specifies the character vertical direction position for the data expansion starting position using the absolute position based on the starting point in page mode. The position of the character vertical direction for the next data expansion starting position is the position specified by $[(nL + nH \times 256) \times \text{basic calculated pitch}]$ from the starting point.															
Details	<ul style="list-style-type: none"> <li>• When not in page mode, this command is ignored.</li> <li>• Specifications for absolute positions that exceed the specified print range are ignored.</li> <li>• The position of the character horizontal direction of the data expansion starting position does not move.</li> <li>• The starting point that is used as a reference is specified by ESC T.</li> <li>• The following operations occur depending on the starting point of (Selecting the character printing direction in page mode) ESC T.             <ol style="list-style-type: none"> <li>a. If the starting point is upper left or lower right, specify the absolute position for the paper feed direction (character vertical direction). Use the basic calculated pitch (y) for the horizontal direction at this time.</li> <li>b. If the starting point is upper right or lower left, specify the absolute position for the paper feed in the vertical direction (character vertical direction). Use the basic calculated pitch (x) for the horizontal direction at this time.</li> </ol> </li> <li>• The basic calculated pitch is set by GSP (Set basic calculated pitch).</li> <li>• If the calculation results in fractions, the pitch is corrected to a minimal mechanical pitch and the rest is discarded.</li> </ul>															
Reference	ESC \$, ESC T, ESC W, ESC \, GS P, GS \ See section 2. Explanations of the Page Mode.															



**GS \* xy d1 ... d (xX yX 8)**

Name	Define download bit images				
Code	ASCII	GS	*	x	yd1...d (x*y*8)
	Hex.	1D	2A	x	yd1...d (x*y*8)
	Decimal	29	42	x	yd1...d (x*y*8)
Defined Region	$1 \leq x \leq 255$				
	$1 \leq y \leq 48$ However, $x \times y \leq 1536$				
	$0 \leq d \leq 255$				
Function	Defines the download bit image of the number of dots specified by x and y. <ul style="list-style-type: none"> <li>• x specifies the number of dots in the horizontal direction.</li> <li>• y specifies the number of bytes in the vertical direction.</li> </ul>				
Details	<ul style="list-style-type: none"> <li>• Horizontal direction dot count is x X 8 dots; Vertical direction dot count is y X 8 dots</li> <li>• d indicates the bit-image data.             <p style="margin-left: 20px;">Bits that correspond to the dots to print are 1, and the bits that correspond to the dots that are not printed are 0.</p> </li> <li>• GS * (define download bit images) and ESC&amp; (define download characters) cannot both be defined simultaneously. Download character definitions are cleared by executing this command.</li> <li>• Defined download bit images are cleared under the following executions.             <ol style="list-style-type: none"> <li>a. ESC @: Initialize printer</li> <li>b. ESC &amp;: Define download characters</li> <li>c. FS q: Define NV bit image</li> <li>d. When the printer is reset or the power is turned off</li> </ol> </li> <li>• The following illustration shows the relationship between download bit images and the print data.</li> </ul>				

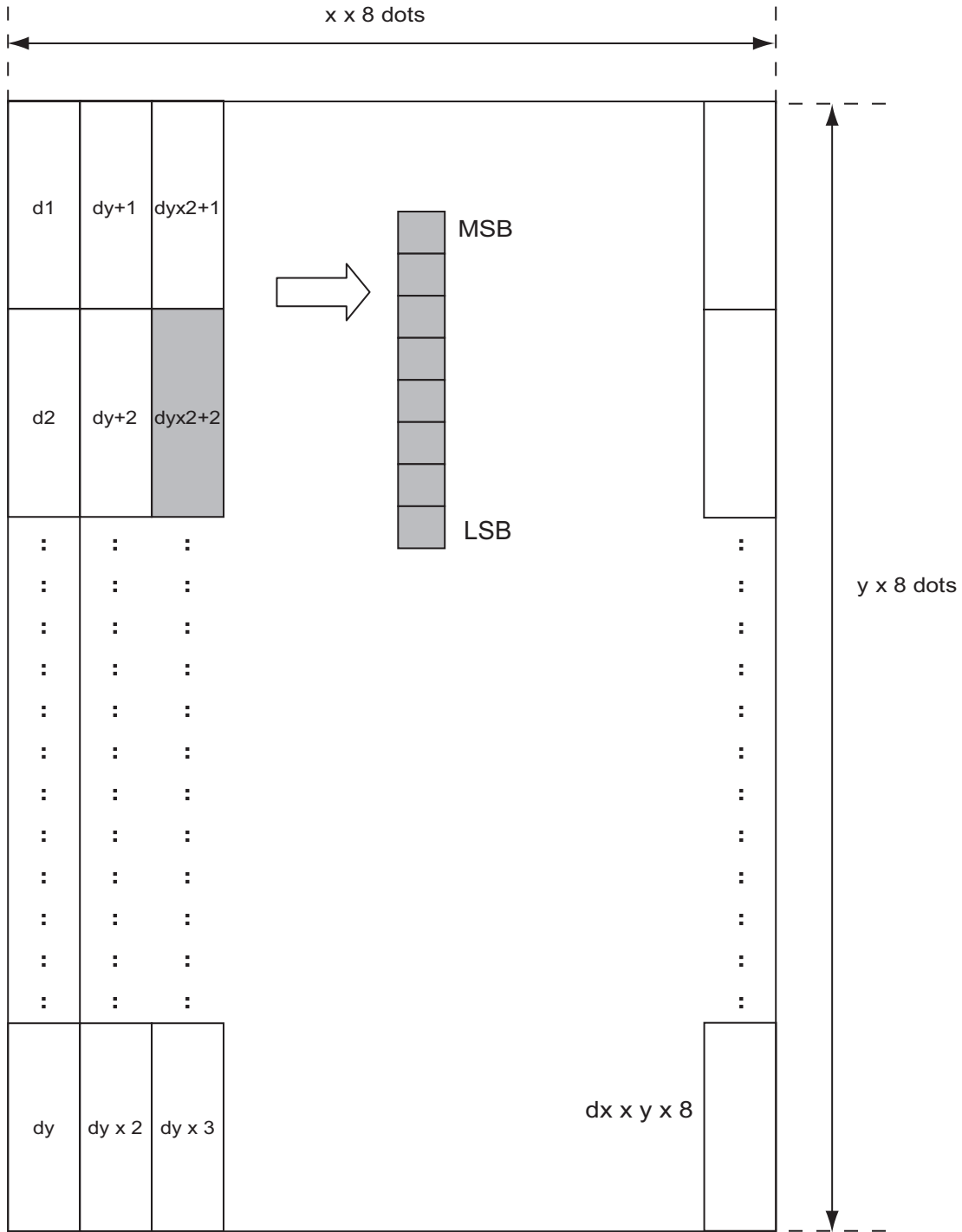

Reference GS /

**GS ( A pL pH n m**

Name	Test print							
Code	ASCII	GS	(	A	pL	pH	n	m
	Hex.	1D	28	41	pL	pH	n	m
	Decimal	29	40	65	pL	pH	n	m

Defined Region {pL+ (pH×256) } = 2 (pL = 2, pH = 0)  
 $0 \leq n \leq 2, 48 \leq n \leq 50$   
 $1 \leq m \leq 3, 49 \leq m \leq 51$

Function Executes the specified test print.

- Specifies the parameter count following pL and pH in (pL + (pH x 256)) bytes.
- n specifies the paper to use in the test print shown in the tables below.

n	Paper Type
0, 48	Basic sheet (paper roll)
1, 49 2, 50	Paper Roll

- m specifies the type of test print shown in the tables below.

m	Type of Test Print
1, 49	Hex. Dump
2, 50	Printer Status (Self Print)
3, 51	Rolling Pattern Print

Details

- This command is effective only when processed at the top of the line when standard mode is being used.
- When in page mode, this command is ignored.
- When processing this command while defining a macro, the macro definition is terminated and the command commences with processing.
- After the test print is completed, the printer executes a hardware reset. Therefore, download characters and download bit images and macros are handled as being undefined and the reception buffer and print buffer are cleared. The printer returns all settings to their default status.
- After the final test print, this executes a paper cut.
- After the command is processed, the printer enters a BUSY state.

**<Function 49> GS ( K pL pH fn m (Fn=49)**

Name Set print density

Code ASCII GS ( K pL pH fn m  
 Hex. 1D 28 4B pL pH fn m  
 Decimal 29 40 75 pL pH fn m

Defined Region {pL + (pH × 256) } = 2 (pL = 2, pH = 0)  
 fn = 49  
 $250 \leq m \leq 255, 0 \leq m \leq 6$

Initial Value m = 0

Function Sets print density.

## Spec. A

m	Print Density
250	0.7
251	0.7
252	0.8
253	0.8
254	0.9
255	0.9
0	1.0
1	1.1
2	1.1
3	1.2
4	1.2
5	1.3
6	1.3

## Spec. B

m	Print Density	
	Single Color Printing Mode	2-color Printing Mode Red Print Density Double Resolution Mode *1
250	Print density -3	Print density -1
251	Print density -3	Print density -1
252	Print density -2	Print density -1
253	Print density -2	Print density -1
254	Print density -1	Standard print density (Standard)
255	Print density -1	Standard print density (Standard)
0	Standard print density (Standard)	Standard print density (Standard)
1	Print density + 1	Standard print density (Standard)
2	Print density + 1	Standard print density (Standard)
3	Print density + 2	Print density + 1
4	Print density + 2	Print density + 1
5	Print density + 3	Print density + 1
6	Print density + 3	Print density + 1

\*1) See the appropriate printer specifications manual for details on the print modes that are available.

## Spec. C

m	Print Density	
	Single Color Printing Mode	2-color Printing Mode Red Print Density Double Resolution Mode *2
0	Standard print density (Standard)	Standard print density (Standard)
1	Print density + 1	Standard print density (Standard)
2	Print density + 1	Standard print density (Standard)
3	Print density + 2	Print density + 1
4	Print density + 2	Print density + 1
5	Print density + 3	Print density + 1
6	Print density + 3	Print density + 1

\*2) See the appropriate printer specifications manual for details on the print modes that are available.

**STAR**

This command changes the print density after the test print is stopped.

When in two-color print mode, you can only set print density for red print using this command.

The print density setting using this command is invalid when in low peak current mode.

**<Function 50> GS ( K pL pH fn m (Fn=50)**

Name	Set printing speed							
Code	ASCII	GS	(	K	pL	pH	fn	m
	Hex.	1D	28	4B	pL	pH	fn	m
	Decimal	29	40	75	pL	pH	fn	m
Defined Region	{pL + (pH × 256) } = 2 (pL = 2, pH = 0)							
	fn = 50							
	Spec.A	0 ≤ m ≤ 9, 48 ≤ m ≤ 57						
	Spec.B	0 ≤ m ≤ 3, 7 ≤ m ≤ 9, 48 ≤ m ≤ 51, 55 ≤ m ≤ 57						
Initial Value	m = 9							
Function	Sets printing speed.							

m	Printing Speed
0, 48	MSW Load Settings (default)
1, 49	Slow speed
2, 50	Slow speed
3, 51	Slow speed
4, 52	Mid-speed
5, 53	Mid-speed
6, 54	Mid-speed
7, 55	High speed
8, 56	High speed
9, 57	High speed

STAR                      The speed setting is disabled during reduced printing in the vertical direction. However, this command setting is enabled when reduced printing in the vertical direction is released.

GS ( L pL pH m fn [parameter]
GS 8 L p1 p2 p3 p4 m fn [parameter]

Name Specify graphics data

Code	ASCII	GS	(	L	pL	pH	m	fn	[parameter]
	Hex.	1D	28	4C	pL	pH	m	fn	parameter]
	Decimal	29	40	76	pL	pH	m	fn	[parameter]

Code	ASCII	GS	8	L	p1	p2	p3	p4	m	fn	[parameter]
	Hex.	1D	38	4C	p1	p2	p3	p4	m	fn	[parameter]
	Decimal	1D	29	56	76	p1	p2	p3	p4	m	fn [parameter]

(\*) Use the GS ( L code to explain each function.

- GS ( L and GS 8 L are the same function.
- If [parameter] in each function exceeds 65533 bytes, use GS 8 L.

Function Runs the process related to the graphics data specified by the function code (fn).

fn	Code	Function No.	Function	For STAR
0, 48	GS ( L pL pH m fn	48	Send NV graphics memory capacity	Supported
2, 50	GS ( L pL pH m fn	50	Print raster graphics data	Receive and discard
3, 51	GS ( L pL pH m fn	51	Send remaining NV graphics memory capacity	Supported
64	GS ( L pL pH m fn d1 d2	64	Send NV graphics key code	Supported
65	GS ( L pL pH m fn d1 d2 d3	65	Batch all delete NV graphics data	Supported
66	GS ( L pL pH m fn kc1 kc2	66	Delete the specified NV graphics data	Supported
67	GS ( L pL pH m fn a kc1 kc2 b xL xH yL yH [c d1...dk]1 [c d1...dk]b	67	Define NV graphics data	Supported
69	GS ( L pL pH m fn a kc1 kc2 x y	68	Print the specified NV graphics data	Supported
112	GS ( L pL pH m fn a bx by c xL xH yL yH d1...dk	112	Store raster graphics data	Supported

**<Function 48> GS ( L pL pH m fn (fn=48)**
**<Function 48> GS 8 L p1 p2 p3 p4 m fn (fn=48)**

Name Send NV graphics memory capacity

Code ASCII GS ( L pL pH m fn  
 Hex. 1D 28 4C pL pH m fn  
 Decimal 29 40 76 pL pH m fn  
 ASCII GS 8 L p1 p2 p3 p4 m fn  
 Hex. 1D 38 4C p1 p2 p3 p4 m fn  
 Decimal 29 56 76 p1 p2 p3 p4 m fn

Defined Region

- Parameter for GS ( L  
 $(pL+pH \times 256)=2$  ( $pL=2$ ,  $pH=0$ )
- Parameter for GS 8 L  
 $(p1+p2 \times 256+p3 \times 65536+p4 \times 16777216)=2$  ( $p1=2$ ,  $p2=0$ ,  $p3=0$ ,  $p4=0$ )
- Parameter are shared by for GS ( L and GS 8 L.

$m = 48$ ,  
 $fn = 0, 48$

Function Sends the entire capacity of NV graphics area in bytes.

Details

- The byte count is sent in the following format:

Transmission data	Hex	Decimal	Data length
Header	37H	55	1 Byte
Identifier	30H	48	1 Byte
Total capacity *1	30H to 39H	48 to 57	1 to 8 Byte
NUL	00H	0	1 Byte

\*1 The total capacity is the total number of bytes in this region.

The decimal value indicating the total capacity is converted to text data and sent in order from the MSB.

Ex.: When the total capacity is 1200 bytes:

“1200” (Hex:31H, 32H, 30H, 30H, Decimal:49, 50, 48, 48) is converted to 4-bytes of data.

- This command is used when sending total capacity, and the total byte capacity of the region is sent regardless of the current setting for the NV graphics data. This total capacity includes the information region.
- When the value that indicates the entire capacity is “0” (Hex:30H, Decimal:48), it is not possible to use the NV graphics function.

Note

- Data transmission process: Function 48, 51, 52, 64

Observe the following rules when using these functions.

- When the host PC sends this command, the printer sends response data or the status to the PC.  
 The PC does not send any more data until it receives response data or status from the printer.
- When using a serial interface, configure operations for the host PC to use the printer only while the printer is in the READY state.
- When using a parallel interface, data sent by this function ([header to NUL] block) is temporarily stored in the transmission buffer of the printer in the same way as other data. When the host PC enters reverse mode, data is sent from the top of the transmission buffer in order.
- When the amount of data exceeds the capacity of the transmission buffer, data is erased.  
 When using this command, it is important to set operations so that the host PC immediately enters a reverse mode and quickly processes the status transmission.
- When using the Xon/Xoff mode communications of the serial interface, it is possible to use Xoff in a data string of [header to NUL].
- Transmission information of each function can be identified as other transmission data by specific data (identifier) of the transmission data string.  
 When the header sent by the printer is [Hex = 37H/Decimal = 55], data up to NUL  
 [Hex = 00H/Decimal = 0] is handled as one group, and identified by corresponding to the combination of the header and identifier.



**<Function 51> GS ( L pL pH m fn (fn=51)**
**<Function 51> GS 8 L p1 p2 p3 p4 m fn (fn=51)**

Name Send NV graphics memory capacity

Code ASCII GS ( L pL pH m fn  
 Hex. 1D 28 4C pL pH m fn  
 Decimal 29 40 76 pL pH m fn  
 ASCII GS 8 L p1 p2 p3 p4 m fn  
 Hex. 1D 38 4C p1 p2 p3 p4 m fn  
 Decimal 29 56 76 p1 p2 p3 p4 m fn

Defined Region

- Parameter for GS ( L  
 $(pL+pH \times 256)=2$  (pL=2, pH=0)
- Parameter for GS 8 L  
 $(p1+p2 \times 256+p3 \times 65536+p4 \times 16777216)=2$  (p1=2, p2=0, p3=0, p4=0)
- Parameter are shared by for GS ( L and GS 8 L.  
 m = 48,  
 fn = 3, 51

Function Sends the remaining capacity (or unused area) of NV graphics area in bytes.

Details

- Sends the number of bytes in the following format.:

Transmission data	Hex	Decimal	Data length
Header	37H	55	1 Byte
Identifier	30H	48	1 Byte
Unused capacity *1	30H to 39H	48 to 57	1 to 8 Byte
NUL	00H	0	1 Byte

\*1 The unused capacity is the total number of bytes of the unused region.

The decimal value indicating the unused capacity is converted to text data and sent in order from the MSB.

Ex.: When the unused capacity is 120 bytes:

“120” (Hex:31H, 32H, 30H, Decimal:49, 50, 48) is converted to 3-bytes of data.

- Information region is also included in the use capacity.
- Do not use this function at the same time as the NV bit image (FS q) command.
- See the Note for <Function 48> for a detailed explanation of the sending process.

Reference FS q, GS ( L/GS 8 L <Function 48>

**<Function 64> GS ( L pL pH m fn d1 d2 (fn=64)**
**<Function 64> GS 8 L p1 p2 p3 p4 m fn d1 d2 (fn=64)**

Name Send a key code list of predefined NV graphics

Code ASCII GS ( L pL pH m fn d1 d2

Hex. 1D 28 4C pL pH m fn d1 d2

Decimal 29 40 76 pL pH m fn d1 d2

ASCII GS 8 L p1 p2 p3 p4 m fn d1 d2

Hex. 1D 38 4C p1 p2 p3 p4 m fn d1 d2

Decimal 29 56 76 p1 p2 p3 p4 m fn d1 d2

Defined Region

- Parameter for GS ( L  
 $(pL+pH \times 256)=4$  (pL=4, pH=0)
- Parameter for GS 8 L  
 $(p1+p2 \times 256+p3 \times 65536+p4 \times 16777216)=4$  (p1=4, p2=0, p3=0, p4=0)
- Parameter are shared by for GS ( L and GS 8 L.  
 m = 48,  
 fn = 64  
 d1 = 75, d2 = 67

Function Sends the defined NV graphics key code list.

Details • Sends the key code in the following format:

Transmission data	Hex	Decimal	Data length
Header	37H	55	1 Byte
Identifier	72H	114	1 Byte
Identifier information *1, 2	40H/41H	64/65	1 Byte
Data	20H to 7EH	32 to 126	2 to 80 Byte
NUL	00H	0	1 Byte

\*1 Send one block with identification information (3rd byte) as 40Hex, when the defined NV graphics data count is less than 40.

\*2 Send one block with identification information (3rd byte) as 41Hex, when the defined NV graphics data count is over 41.

• If there is no defined NV graphics key code list, it sends the following format.

Transmission data	Hex	Decimal	Data length
Header	37H	55	1 Byte
Identifier	72H	114	1 Byte
Identifier information	40H	64	1 Byte
NUL	00H	0	1 Byte

• Do not use this function at the same time as the NV bit image (FS q) command. NV bit images defined by <FS q> are determined to have no data.

• See the Note for <Function 48> for a detailed explanation of the sending process.

Reference FS q, GS ( L/GS 8 L <Function 48>

**<Function 65> GS ( L pL pH m fn d1 d2 d3 (fn=65)**

**<Function 65> GS 8 L p1 p2 p3 p4 m fn d1 d2 d3 (fn=65)**

Name Erase entire NV graphics data

Code ASCII GS ( L pL pH m fn d1 d2 d3  
 Hex. 1D 28 4C pL pH m fn d1 d2 d3  
 Decimal 29 40 76 pL pH m fn d1 d2 d3

ASCII GS 8 L p1 p2 p3 p4 m fn d1 d2 d3  
 Hex. 1D 38 4C p1 p2 p3 p4 m fn d1 d2 d3  
 Decimal 29 56 76 p1 p2 p3 p4 m fn d1 d2 d3

Defined Region

- Parameter for GS ( L  
 $(pL+pH \times 256)=5$  (pL=5, pH=0)
- Parameter for GS 8 L  
 $(p1+p2 \times 256+p3 \times 65536+p4 \times 16777216)=5$  (p1=5, p2=0, p3=0, p4=0)
- Parameter are shared by for GS ( L and GS 8 L.  
 m = 48,  
 fn = 65  
 d1 = 67, d2 = 76, d3 = 82

Function Erases all NV graphics data defined by Function 67.

- The erased area is set to be an “unused area.”
- All key codes become undefined.

Details

- Effective only at the top of the line in standard mode.
- Data for this parameter is discarded in page mode.
- Do not use this function for macro definition because this function is not compatible with the macros.
- If you use this function, all NV graphics data is erased. Take special care if NV graphics data is used in multiple applications.
- This function also erases the NV graphics data defined by the “FS q” command.

Reference FS q, GS ( L/GS 8 L <Function 67>

**<Function 66> GS ( L pL pH m fn kc1 kc2 (fn=66)**

**<Function 66> GS 8 L p1 p2 p3 p4 m fn kc1 kc2 (fn=66)**

Name	Erase the specified NV graphics data
Code	ASCII GS ( L pL pH m fn kc1 kc2 Hex. 1D 28 4C pL pH m fn kc1 kc2 Decimal 29 40 76 pL pH m fn kc1 kc2  ASCII GS 8 L p1 p2 p3 p4 m fn kc1 kc2 Hex. 1D 38 4C p1 p2 p3 p4 m fn kc1 kc2 Decimal 29 56 76 p1 p2 p3 p4 m fn kc1 kc2
Defined Region	<ul style="list-style-type: none"> <li>• Parameter for GS ( L (pL+pH×256)=4 (pL=4, pH=0)</li> <li>• Parameter for GS 8 L (p1+p2×256+p3×65536+p4×16777216)=4 (p1=4, p2=0, p3=0, p4=0)</li> <li>• Parameter are shared by for GS ( L and GS 8 L. m = 48, fn = 66 32 ≤ kc1 ≤ 126 32 ≤ kc2 ≤ 126</li> </ul>
Function	Erases the NV graphics data defined by key codes kc1 and kc2. <ul style="list-style-type: none"> <li>• The erased area is set to be an “unused area.”</li> <li>• The erased key code becomes undefined.</li> </ul>
Details	<ul style="list-style-type: none"> <li>• Effective only at the top of the line in standard mode.</li> <li>• Data for this counter is discarded in page mode.</li> <li>• Do not use this function for macro definition because this function is not compatible with the macros.</li> </ul>
Reference	GS ( L/GS 8 L <Function 67>

**<Function 67> GS ( L pL pH m fn a kc1 kc2 b xL xH y L yH [c d1 ... dk] 1 ... [c d1 ... dk] b (fn=67)**

**<Function 67> GS 8 L p1 p2 p3 p4 m fn a kc1 kc2 b xL xH y L yH [c d1 ... dk] 1 ... [c d1 ... dk] b (fn=67)**

Name	Define NV graphics data (in raster format)
Code	ASCII GS ( L pL pH m fn a kc1 kc2 b xL xH y L yH [c d1 ... dk] 1 ... [c d1 ... dk] b Hex. 1D 28 4C pL pH m fn a kc1 kc2 b xL xH y L yH [c d1 ... dk] 1 ... [c d1 ... dk] b Decimal 29 40 76 pL pH m fn a kc1 kc2 b xL xH y L yH [c d1 ... dk] 1 ... [c d1 ... dk] b  ASCII GS 8 L p1 p2 p3 p4 m fn a kc1 kc2 b xL xH y L yH [c d1 ... dk] 1 ... [c d1 ... dk] b Hex. 1D 38 4C p1 p2 p3 p4 m fn a kc1 kc2 b xL xH y L yH [c d1 ... dk] 1 ... [c d1 ... dk] b Decimal 29 56 76 p1 p2 p3 p4 m fn a kc1 kc2 b xL xH y L yH [c d1 ... dk] 1 ... [c d1 ... dk] b

Defined Region

- Parameter for GS ( L
  - $12 \leq (pL+pH \times 256) \leq 65535$  ( $0 \leq pL \leq 255$ ,  $0 \leq pH \leq 255$ )
- Parameter for GS 8 L
  - $12 \leq (p1+p2 \times 256+p3 \times 65536+p4 \times 16777216) \leq 4294967295$
  - ( $0 \leq p1 \leq 255$ ,  $0 \leq p2 \leq 255$ ,  $0 \leq p3 \leq 255$ ,  $0 \leq p4 \leq 255$ )
- Parameter are shared by for GS ( L and GS 8 L.
  - $m = 48$ ,  $fn = 67$ ,  $a = 48$
  - $32 \leq kc1 \leq 126$
  - $32 \leq kc2 \leq 126$
  - $b = 1, 2$
  - $1 \leq (xL+xH \times 256) \leq 8192$ , ( $0 \leq xL \leq 255$ ,  $0 \leq xH \leq 32$ )
  - $1 \leq (yL+yH \times 256) \leq 2304$ , ( $0 \leq yL \leq 255$ ,  $0 \leq yH \leq 9$ )
  - $c = 49$  (Single-color),  $c = 49,50$  (2-color)
  - $0 \leq d \leq 255$
  - $k = \text{int}(((xL + xH \times 256) + 7) \div 8) \times (yL + yH \times 256)$

Function

Defines the NV graphics data (in raster format) as the record specified by key codes kc1 and kc2.

- “b” specifies a number of colors of the definition data.
- “xL” and “xH” specify the horizontal size of definition data to “xL + xH x 256” dots.
- “yL” and “yH” specify the vertical size of definition data to “yL + yH x 256” dots.
- “c” specifies the definition data color as follows.
  - c=49: Black
  - c=50: Red
- “d” specifies the definition data (in raster format).
- If the specified key code already exists in memory, it is overwritten by the specified one.

**Details**

- NV graphics are image data defined in the non-volatile memory of the printer.  
Data definitions for NV graphics data generated by using this command are valid until redefined by this command.
- This command is used to define NV graphics data.
  - This function is defined by the raster format.
- Valid only at the top of the line in standard mode.
- When page mode is selected, counter data is received and discarded.
- Do not use this function when defining a macro because it is not compatible with macros.
- If there is not an adequate amount of space to store the NV graphics data, this function cannot be use.  
Use Function 51 to check the available space that can be used.
- k byte data d1 ... dk are processed as one item of the defined NV graphics data.  
Bits that correspond to the dots to print are "1," and the bits that correspond to the dots that are not printed are "0."
- When single-color (b=1) is selected, this is defined as one data group [c d1 ... dk].
- When 2-color (b=2) is selected, this is defined as two data groups [c d1 ... dk].  
When a color (c) is specified, it is important to specify a color different from the data group.  
At that time, the vertical and horizontal sizes of the data are the same.
- NV graphics data is printed using Function 69.
- Be aware that this command and NV bit image data (FS q) cannot both be defined at the same time.  
The NV bit image data definition (FS q) is erased by using this command.
- The relationship of NV graphics data (raster format) and printing results are shown below.

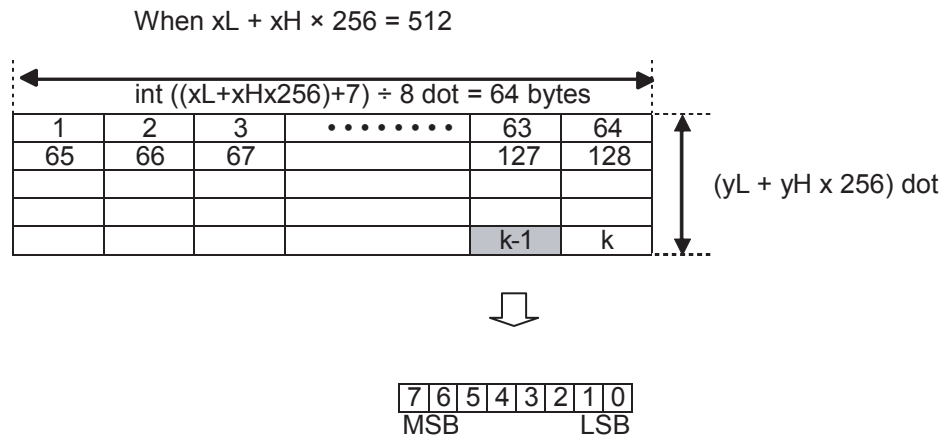
**Notes**

- When the specification of  $(xL + xH \times 256)$ , and  $(yL + yH \times 256)$  exceed the remaining capacity of the NV graphics region, this function does not operate.
- When processing this function when the NV bit image is defined using FS q, after all NV bit images are deleted, define data using this function.
- This function uses the NV graphics area of "Number of data sets (k) + Management data (14 bytes)".
- The NV bit image data defined by this command is printable by "FS p". See Appendix-11 for setting details.

Reference GS ( L/GS 8 L <Function 51>, <Function 69>, FS q, Appendix-11

**<Function 69> GS ( L pL pH m fn kc1 kc2 x y (fn=69)**

**<Function 69> GS 8 L p1 p2 p3 p4 m fn kc1 kc2 x y (fn=69)**

Name	Print the specified NV graphics data
Code	<p>ASCII GS ( L pL pH m fn kc1 kc2 x y</p> <p>Hex. 1D 28 4C pL pH m fn kc1 kc2 x y</p> <p>Decimal 29 40 76 pL pH m fn kc1 kc2 x y</p> <p>ASCII GS 8 L p1 p2 p3 p4 m fn kc1 kc2 x y</p> <p>Hex. 1D 38 4C p1 p2 p3 p4 m fn kc1 kc2 x y</p> <p>Decimal 29 56 76 p1 p2 p3 p4 m fn kc1 kc2 x y</p>
Defined Region	<ul style="list-style-type: none"> <li>• Parameter for GS ( L (pL+pH×256)=6 (pL=6, pH=0)</li> <li>• Parameter for GS 8 L (p1+p2×256+p3×65536+p4×16777216)=6 (p1=6, p2=0, p3=0, p4=0)</li> <li>• Parameter are shared by for GS ( L and GS 8 L.</li> </ul> <p>m = 48</p> <p>fn = 69</p> <p>32 ≤ kc1 ≤ 126</p> <p>32 ≤ kc2 ≤ 126</p> <p>x = 1, 2</p> <p>y = 1, 2</p>
Function	<p>Prints the NV graphics data defined by key codes kc1 and kc2.</p> <ul style="list-style-type: none"> <li>• Selected data can be printed in the “horizontal x-times” by “vertical y-times” scale.</li> </ul>
Details	<ul style="list-style-type: none"> <li>• This function is used to print the NV graphics data defined by Function 67.</li> <li>• The printer prints data only when the NV graphics data that matches the specified key code is defined.</li> <li>• If data with the specified key code is not found, the data of this counter is discarded.</li> <li>• This command is effective only when no data exists in the print buffer in standard mode.</li> <li>• If any data exists in the print buffer, the data for this counter is discarded.</li> <li>• Data for this counter is discarded in page mode.</li> <li>• If graphics that exceeds the print area size is specified, the data within the print area is printed out but the excess data is not printed out.</li> <li>• The horizontal and vertical size of NV graphics can be specified by “x” and “y”.</li> <li>• Excluding upside-down printing, print modes (emphasized printing, overlap printing, underlines, character sizes, black/white inverted printing, and 90 degree rotation) are unaffected.</li> <li>• When normal mode or double-width mode is specified, the paper is fed for the number of dots (the height of NV graphics) and when double-height mode or 4x mode is specified, the paper is fed for the number of dots (NV graphics height multiplied by 2) regardless of the settings of default line spacing (ESC 2) and line feed amount (ESC 3).</li> <li>• After these graphics are printed, the next printing starts at the beginning of a line (the printer is at the “beginning of the line” and has “no print data”), and subsequent data is processed as normal data.</li> </ul>

- This command is affected by the following command settings:

Alignment (ESC a n)

Move to absolute position (ESC \$ n1 n2)

Move to relative position (ESC \ n1 n2)

Set print area (ESC RS A n)

Horizontal tab (HT)

Upside-down printing (ESC { n)

#### Notes

- The following explains the DPI and the maximum print area.
- “Vertical” refers to the paper feeding direction, and “horizontal” refers to a direction perpendicular to the paper feed direction.

#### Star

- Dot density of STAR printers (STAR printer head: 203 DPI)

X x Y	Mode	Horizontal Direction Dot Density	Vertical Direction Dot Density
1 x 1	Normal mode	203 DPI	203 DPI
1 x 2	Double-high Mode	203 DPI	101 DPI
2 x 1	Double-wide Mode	101 DPI	203 DPI
2 x 2	Double-high, Double-wide Mode	101 DPI	101 DPI

#### Reference

GS ( L/GS 8 L , ESC 2 , ESC 3 , ESC a , ESC \$ , ESC \ , ESC RS A , HT , ESC {



**<Function 112> GS ( L pL pH m fn a bx by c xL xH yL yH d1...dk (fn=112)**

**<Function 112> GS 8 L p1 p2 p3 p4 m fn a bx by c xL xH yL yH d1...dk (fn=112)**

Name Stores raster-format graphics data in print buffer.

Code ASCII GS ( L pL pH m fn a bx by c xL xH yL yH d1... dk  
 Hex. 1D 28 4C pL pH m fn a bx by c xL xH yL yH d1 ... dk  
 Decimal 29 40 76 pL pH m fn a bx by c xL xH yL yH d1 ... dk  
 ASCII GS 8 L p1 p2 p3 p4 m fn a bx by c xL xH yL yH d1 ... dk  
 Hex. 1D 38 4C p1 p2 p3 p4 m fn a bx by c xL xH yL yH d1 ... dk  
 Decimal 29 56 76 p1 p2 p3 p4 m fn a bx by c xL xH yL yH d1 ... dk

Defined Region

- Parameter for GS ( L
  $11 \leq (pL+pH \times 256) \leq 65535$  ( $0 \leq pL \leq 255, 0 \leq pH \leq 255$ )
- Parameter for GS 8 L
  $11 \leq (p1+p2 \times 256+p3 \times 65536+p4 \times 16777216) \leq 4294967295$  ( $0 \leq p1 \leq 255, 0 \leq p2 \leq 255, 0 \leq p3 \leq 255, 0 \leq p4 \leq 255$ )
- Parameter are shared by for GS ( L and GS 8 L.
 

$m = 48, fn = 112, a = 48,$

$1 \leq bx \leq 2, 1 \leq by \leq 2$

$49 \leq c \leq 50$  (c=49: Single color, c=50: Two-color)

$1 \leq U (xL+xH \times 256) \leq 2047$

  - When single color is specified
 

$1 \leq (yL+yH \times 256) \leq 1662$  (When by=1)

$1 \leq (yL+yH \times 256) \leq 831$  (When by=2)
  - When two-color is specified
 

$1 \leq (yL+yH \times 256) \leq 831$  (When by=1)

$1 \leq (yL+yH \times 256) \leq 415$  (When by=2)

$0 \leq d \leq 255$

$k = (\text{int}((xL+yH \times 256)+7)/8) \times (yL+yH \times 256)$

Function Stores raster-format graphics data in the print buffer using horizontal bx/vertical by.

- xL and xH specify the horizontal direction of the raster graphic in (xL + xH×256) dots.
- yL and yH specify the vertical direction of the raster graphic in (yL + yH×256) dots.
- c specifies the color of the print data.

c	Print Data Color
49	First Color (Black: High Energy)
50	Second Color (Red: Low Energy)

STAR

- Prints using this command.
 

With EPSON specifications, 1) after the data is stored in the print buffer, 2) that data stored in the print buffer is printed, but with STAR specifications, 1) the command prints the graphics data, then 2) the printer receives the print command for the data stored in the printer buffer, and discards it.

1) GS ( L pL pH m fn a bx by c xL xH yL yH d1 ... dk (fn=112)

2) GS ( L pL pH m fn (fn=2, 50)
- When c=50 (Two color) is specified, the command is ignored.
- The command is processed as normal data in Page mode.

Reference GS ( L pL pH m fn (fn=2, 50)

**GS ( N pL pH n m**

Name Specify print color

Code	ASCII	GS	(	N	pL	pH	n	m
	Hex.	1D	28	4E	pL	pH	n	m
	Decimal	29	40	78	pL	pH	n	m

Defined Region {pL+ (pH×256) } = 2 (pL = 2,pH = 0)  
 n = 48  
 m = 49,50

Initial Value m = 49

Function Specifies print color in 2 color print mode.

- This command is effective only when in 2 color printing in mode. This command is ignored with in single color printing mode.
- Use ESC @ to initial the print color (print color = black).

m	Print color
49	Black (High Energy)
50	Red (Low Energy)

**GS ( k pL pH cn fn [parameter])**

Name	Set and print symbol							
Code	ASCII	GS	(	k	pL	pH	cn	fn [parameter]
	Hex.	1D	28	6B	pL	pH	cn	fn [parameter]
	Decimal	29	40	107	pL	pH	cn	fn [parameter]
Function	Runs processes related to symbol.							
	<ul style="list-style-type: none"> <li>• pL and pH specify the parameter count (pL + pH x 256) in bytes after cn.</li> <li>• Specifies the type of symbol with cn.</li> <li>• Specifies the function with fn.</li> <li>• See the function specifications for details on [parameter].</li> </ul>							

cn	Type of Symbol
48	PDF417 (2-dimensional code)
49	QR Code (2-dimensional code)
51	2D GS1 DataBar (GS1 DataBar Stacked, GS1 DataBar Stacked Omnidirectional, GS1 DataBar Expanded Stacked)
52	GS1 compound symbol

cn	fn	Function No.	Function Name
48	65	Function 065	PDF417: Set number of positions
	66	Function 066	PDF417: Set number of levels
	67	Function 067	PDF417: Set module width
	68	Function 068	PDF417: Set level height
	69	Function 069	PDF417: Set error correction level
	70	Function 070	PDF417: Select options
	80	Function 080	PDF417: Store data in symbol saving region
	81	Function 081	PDF417: Print symbol data of symbol saving region
49	82	Function 082	PDF417: Send size information of symbol data in symbol saving region
	65	Function 165	QR Code: Set model
	67	Function 167	QR Code: Set module siz
	69	Function 169	QR Code: Select error correction level
	80	Function 180	QR Code: Store data in symbol saving region
	81	Function 181	QR Code: Print symbol data of symbol saving region
51	82	Function 182	QR Code: Send size information of symbol data in symbol saving region
	67	Function 367	2D GS1 DataBar: Set module siz
	71	Function 371	2D GS1 DataBar: Set The maximum width of the 2D GS1DataBar Expanded Stacked
	80	Function 380	2D GS1 DataBar: Store data in symbol saving region
52	81	Function 381	2D GS1 DataBar: Print symbol data of symbol saving region
	67	Function 467	Compound symbol: Set module siz
	71	Function 471	Compound symbol:Set The maximum width of the 2D GS1DataBar Expanded Stacked
	72	Function 472	Compound symbol: Set HRI Font
	80	Function 480	Compound symbol: Store data in symbol saving region
	81	Function 481	Compound symbol: Print symbol data of symbol saving region

**<Function 065> GS ( k pL pH m cn n (cn=48, fn=65)**

Name	Set PDF417 position count (level length)
Code	ASCII GS ( k pL pH m cn fn n Hex. 1D 28 6B pL pH m cn fn n Decimal 29 40 107 pL pH m cn fn n
Defined Region	pL = 3, pH = 0 cn = 48, fn = 65 $0 \leq n \leq 30$
Initial Value	n = 0
Function	Sets PDF417 symbol position count (level length). <ul style="list-style-type: none"> <li>• When n = 0, sets the automatic process.</li> <li>• When n≠0, sets the number of positions of the symbol data region to n code words.</li> </ul>
Details	<p>The setting of this function affects processes of Functions 081 and 082.</p> <p>When automatic processing is specified (n = 0), the maximum row number in the data region is 30.</p> <p>The following data is not included in the number of positions.</p> <ul style="list-style-type: none"> <li>• Start patterns and stop patterns</li> <li>• Indicator code words of the right and left levels.</li> </ul> <p>The number of positions when automatic processing is specified (n = 0), calculates the number of code words based on the current print region, when processing Functions 081, and 082, module width (Function 067), and the option settings (Function 070).</p> <p>This setting is valid until ESC @ is executed, the printer is reset or the power is turned off.</p>
Reference	GS ( k Function 081, 082, 067, 070, ESC @

**<Function 066> GS ( k pL pH m cn n (cn=48, fn=66)**

Name	Set PDF417 number of symbol levels
Code	ASCII GS ( k pL pH m cn fn n Hex. 1D 28 6B pL pH m cn fn n Decimal 29 40 107 pL pH m cn fn n
Defined Region	pL = 3, pH = 0 cn = 48, fn = 66 n = 0, $3 \leq n \leq 90$
Initial Value	n = 0
Function	Sets the number of levels of the PDF417 symbols. <ul style="list-style-type: none"> <li>• When n = 0, sets the automatic process.</li> <li>• When n≠0, specifies the number of positions of symbols to n levels.</li> </ul>
Details	<p>The setting of this function affects processes of Functions 081 and 082.</p> <p>When automatic processing is specified (n = 0), the maximum row number in the data region is 90.</p> <p>The number of positions when automatic processing is specified (n = 0), calculates based on the current print region, when processing Functions 081, and 082, and module width (Function 068).</p> <p>This setting is valid until ESC @ is executed, the printer is reset or the power is turned off.</p>
Reference	GS ( k Function 081, 082, 068, ESC @

**<Function 067> GS ( k pL pH cn fn n (cn=48, fn=67)**

Name	Set PDF417 module width
Code	ASCII GS ( k pL pH cn fn n Hex. 1D 28 6B pL pH cn fn n Decimal 29 40 107 pL pH cn fn n
Defined Region	pL = 3, pH = 0 cn = 48, fn = 67 $2 \leq n \leq 8$
Initial Value	n = 3
Function	Sets one PDF417 module width to n dots.
Details	The setting of this function affects processes of Functions 081 and 082. This setting is valid until ESC @ is executed, the printer is reset or the power is turned off. Set in units of 1 dot. The width is set in 0.125 mm (1/203 inches) units.
Reference	GS ( k Function 081, 082, ESC @

**<Function 068> GS ( k pL pH cn fn n (cn=48, fn=68)**

Name	Set the PDF417 symbol level height
Code	ASCII GS ( k pL pH cn fn n Hex. 1D 28 6B pL pH cn fn n Decimal 29 40 107 pL pH cn fn n
Defined Region	pL = 3, pH = 0 cn = 48, fn = 68 $2 \leq n \leq 8$
Initial Value	n = 3
Function	Sets one PDF417 symbol module height to [module width x n].
Details	The setting of this function affects processes of Functions 081 and 082. This setting is valid until ESC @ is executed, the printer is reset or the power is turned off.  The height of one level affects the reading rate of symbols. The height of one level is recommended to be set to 3 to 5 times the module width. When the symbol vertical size is less than 5 mm (0.2 inches), there is the possibility that the reading rate will drop. It is possible to check the vertical size of the symbol using the size information status of Function 082.
Reference	GS ( k Function 081, 082, ESC @

**<Function 069> GS ( k pL pH cn fn m n (cn=48, fn=69)**

Name Set the PDF417 error correction level

Code ASCII GS ( k pL pH cn fn m n  
Hex. 1D 28 6B pL pH cn fn m n  
Decimal 29 40 107 pL pH cn fn m n

Defined Region pL = 4, pH = 0  
cn = 48, fn = 69  
 $48 \leq n \leq 56$  (When m = 48)  
 $1 \leq n \leq 40$  (When m = 49)

Initial Value m = 49, n = 1

Function Sets the PDF417 error correction level.

Details The setting of this function affects processes of Functions 081 and 082.

- When m = 48, the error correction level is set by level.

The error correction level set by ratio is discarded.

The number of error correction code words is fixed regardless of the number of code words of the data region.

n	Function	Error Correction Code Word Count
48	Selects error correction level 0.	2
49	Selects error correction level 1.	4
50	Selects error correction level 2.	8
51	Selects error correction level 3.	16
52	Selects error correction level 4.	32
53	Selects error correction level 5.	64
54	Selects error correction level 6.	128
55	Selects error correction level 7.	256
56	Selects error correction level 8.	512

- When m = 49, the error correction level is set by ratio. The ratio is set to  $n \times 10\%$ .

The error correction level set by ratio is discarded.

The error level is determined as shown in the following table on the basis of the result (A) of calculating  $[(\text{data code words} \times n \times 0.1)]$  to the first decimal place rounded to the nearest integer].

The number of error correction code words varies proportionally to the number of code words of the data region.

Calculated Result (A)	Function	Error Correction Code Word Count
0 to 3	Selects error correction level 1.	4
4 to 10	Selects error correction level 2.	8
11 to 20	Selects error correction level 3.	16
21 to 45	Selects error correction level 4.	32
46 to 100	Selects error correction level 5.	64
101 to 200	Selects error correction level 6.	128
201 to 400	Selects error correction level 7.	256
More than 401	Selects error correction level 8.	512

Reference GS ( k Function 081, 082, ESC @

**<Function 70> GS ( k pL pH cn fn m (cn=48, fn=70)**

Name Set PDF417 options

Code ASCII GS ( k pL pH cn fn m  
Hex. 1D 28 6B pL pH cn fn m  
Decimal 29 40 107 pL pH cn fn m

Defined Region pL = 3, pH = 0  
cn = 48, fn = 70  
m = 0, 1

Initial Value m = 0

Function Set PDF417 options

m	Function
0	Selects the standard PDF417 options.
1	Selects the simple PDF417 options.

Details The setting of this function affects processes of Functions 081 and 082.  
This setting is valid until ESC @ is executed, the printer is reset or the power is turned off.

Reference GS ( k Function 081, 082, ESC @

**<Function 080> GS ( k pL pH cn fn m d1...dk (cn=48, fn=80)**

Name Set the PDF417 symbol level height

Code ASCII GS ( k pL pH cn fn m d1...dk  
Hex. 1D 28 6B pL pH cn fn m d1...dk  
Decimal 29 40 107 pL pH cn fn m d1...dk

Defined Region  $4 \leq (pL + pH \times 256) \leq 65535$  ( $0 \leq pL \leq 255$ ,  $0 \leq pH \leq 255$ )  
cn = 48, fn = 80, m = 48  
 $2 \leq d \leq 255$ ,  $k = (pL + pH \times 256) - 3$

Function Stores the symbol data (d1 ... dk) of PDF417 in the symbol saving region.

Details Data stored in the symbol saving region using this function is processed using Function 081 and 082.

After processing Functions 081 and 082, data of the saving region is maintained.

k bytes of d1 ... dk are processed as symbol data.

This function specifies only the data word count of the symbol.

The printer automatically applies this so the following data is not included in the d1 ... dk data.

- Start patterns and stop patterns
- Indicator code words of the right and left levels.
- Descriptor related to symbol length (initial code word of the data region)

This setting is valid until this function is reset, ESC @ is executed, the printer is reset or the power is off.

Reference GS ( k Function 081, 082, ESC @



**<Function 081> GS ( k pL pH cn fn m (cn=48, fn=81)**

Name	Encodes and prints PDF417 symbol data stored in the symbol saving region
Code	ASCII GS ( k pL pH cn fn m Hex. 1D 28 6B pL pH cn fn m Decimal 29 40 107 pL pH cn fn m
Defined Region	pL = 3, pH = 0 cn = 48, fn = 81, m = 48
Function	Executes encoding and printing the symbol data stored in the symbol saving region, by GS ( k Function command.
Note	The user must ensure the quiet zone.
Reference	GS ( k Function 080

**<Function 082> GS ( k pL pH cn fn m (cn=48, fn=82)**

**Name** Send size information of the symbol data of the PDF417 symbol saving region

**Code** ASCII GS ( k pL pH cn fn m  
 Hex. 1D 28 6B pL pH cn fn m  
 Decimal 29 40 107 pL pH cn fn m

**Defined Region** pL = 3, pH = 0  
 cn = 48, fn = 82, m = 48

**Function** Sends the size information of the symbol data stored in the symbol saving region by GS ( k Function 080.

**Details** The size information of the symbol is not printed with the processing of this function.  
 Size information indicates the size of the symbol printed by Function 081.  
 The quiet zone does not include size information.

Data of the size information is shown below.

Transmission data	Hex	Decimal	Data length
Header	37H	55	1Byte
Identifier	2FH	47	1Byte
Horizontal Size *1	30H to 39H	48 to 57	1 to 5 Bytes
Delimiter	1FH	31	1Byte
Vertical Size *1	30H to 39H	48 to 57	1 to 5 Bytes
Delimiter	1FH	31	1Byte
Fixed Value	31H	49	1Byte
Delimiter	1FH	31	1Byte
Other Information *2	30H/31H	48/49	1Byte
NUL	00H	0	1Byte

- \* 1 The horizontal and vertical sizes are shown as the number symbol dots.  
 The decimal value of the horizontal and vertical sizes are converted to character data and sent in order from the MSB.  
 Ex.: When the horizontal size is 120 dots, "120" is converted to 3 bytes of data (Hex:31H, 32H, 30H, Decimal:49, 50, 48).
- \* 2 "Other information" indicates whether it is possible to print symbol data stored in the saving region.

Hex	Decimal	Data length
30H	48	Printable
31H	49	Not printable

**Reference** GS ( k Function 080, 082, ESC @

**<Function 165> GS ( k pL pH cn fn n1 n2 (cn=49, fn=65)**

Name Selects QR Code model  
 Code ASCII GS ( k pL pH cn fn n1 n2  
 Hex. 1D 28 6B pL pH cn fn n1 n2  
 Decimal 29 40 107 pL pH cn fn n1 n2  
 Defined Region pL = 3, pH = 0  
 cn = 49, fn = 65  
 n1 = 49, 50  
 n2 = 0  
 Initial Value n1 = 50, n2 = 0  
 Function Selects QR Code model.

n1	Function
49	Selects the mode 1 conversion processing.
50	Selects the mode 2 conversion processing.

**<Function 167> GS ( k pL pH cn fn n (cn=49, fn=67)**

Name Sets the module size of QR Code  
 Code ASCII GS ( k pL pH cn fn n  
 Hex. 1D 28 6B pL pH cn fn n  
 Decimal 29 40 107 pL pH cn fn n  
 Defined Region pL = 3, pH = 0  
 cn = 49, fn = 67  
 $1 \leq n \leq 16$   
 Initial Value n = 3  
 Function Sets the size of the QR Code module 1 to n dot.

**<Function 169> GS ( k pL pH cn fn m n (cn=49, fn=69)**

**Name** Selects the error correction level for QR Code  
**Code** ASCII GS ( k pL pH cn fn m n  
 Hex. 1D 28 6B pL pH cn fn m n  
 Decimal 29 40 107 pL pH cn fn m n  
**Defined Region** pL = 3, pH = 0  
 cn = 49, fn = 69  
 $48 \leq n \leq 51$   
**Initial Value** n = 48  
**Function** Selects the error correction level for QR Code.

n1	Function	Reference: Approximate figure for recovery
48	Select error correction level 0	7 %
49	Select error correction level 1	15 %
50	Select error correction level 2	25 %
51	Select error correction level 3	30 %

**<Function 180> GS ( k pL pH cn fn m n (cn=49, fn=80)**

**Name** QR Code: Stores symbol data in the symbol storage area.  
**Code** ASCII GS ( k pL pH cn fn m d1...dk  
 Hex. 1D 28 6B pL pH cn fn m d1...dk  
 Decimal 29 40 107 pL pH cn fn m d1...dk  
**Defined Region**  $4 \leq (pL + pH \times 256) \leq 7092$  ( $0 \leq pL \leq 255, 0 \leq pH \leq 27$ )  
 cn = 49, fn = 80, m =48  
 $0 \leq d \leq 255$   
 $k = (pL + pH \times 256) - 3$   
**Function** Stores symbol data (d1...dk) in the QR Code symbol storage area.

**<Function 181> GS ( k pL pH cn fn m (cn=49, fn=81)**

Name	Prints QR Code symbol data stored in the symbol saving region
Code	ASCII GS ( k pL pH cn fn m Hex. 1D 28 6B pL pH cn fn m Decimal 29 40 107 pL pH cn fn m
Defined Region	pL = 3, pH = 0 cn = 49, fn = 81, m = 48
Function	Executes encoding and printing the symbol data stored in the symbol saving region, by GS ( k Function 181 command.
Note	The user must ensure the quiet zone.

**<Function 182> GS ( k pL pH cn fn m (cn=49, fn=82)**

Name	Send size information of the symbol data of the QR Code symbol saving region
Code	ASCII GS ( k pL pH cn fn m Hex. 1D 28 6B pL pH cn fn m Decimal 29 40 107 pL pH cn fn m
Defined Region	pL = 3, pH = 0 cn = 49, fn = 82, m = 48
Function	Sends the size information of the symbol data stored in the symbol saving region by GS ( k Function 080.
Details	The size information of the symbol is not printed with the processing of this function. Size information indicates the size of the symbol printed by Function 181. The quiet zone does not include size information.

Data of the size information is shown below.

Transmission data	Hex	Decimal	Data length
Header	37H	55	1Byte
Identifier	36H	54	1Byte
Horizontal Size *1	30H to 39H	48 to 57	1 to 5 Bytes
Delimiter	1FH	31	1Byte
Vertical Size *1	30H to 39H	48 to 57	1 to 5 Bytes
Delimiter	1FH	31	1Byte
Fixed Value	31H	49	1Byte
Delimiter	1FH	31	1Byte
Other Information *2	30H/31H	48/49	1Byte
NUL	00H	0	1Byte

- \* 1 The horizontal and vertical sizes are shown as the number symbol dots.  
The decimal value of the horizontal and vertical sizes are converted to character data and sent in order from the MSB.  
Ex.: When the horizontal size is 120 dots, "120" is converted to 3 bytes of data (Hex:31H, 32H, 30H, Decimal:49, 50, 48).
- \* 2 "Other information" indicates whether it is possible to print symbol data stored in the saving region.

Hex	Decimal	Data length
30H	48	Printable
31H	49	Not printable

**<Function 367> GS ( k pL pH cn fn n (cn=51, fn=67)**

Name	2D GS1 DataBar: Set module siz
Code	ASCII GS ( k pL pH cn fn n Hex. 1D 28 6B pL pH cn fn n Decimal 29 40 107 pL pH cn fn n
Defined Region	pL = 3, pH = 0 cn = 51 fn = 67 $2 \leq n \leq 8$
Initial Value	n = 2
Function	The width of one module of the 2D GS1 DataBar is set to n dots.
Note	The setting for this function affects the processing of function 381. This setting is enabled until ESC@ is executed, the printer is reset, or the power is turned off. The set unit is 1 dot. The width is set as 0.125 mm (1/203 inches).
Reference	GS ( k Function 381, ESC @

**<Function 371> GS ( k pL pH cn fn nL nH (cn=51, fn=71)**

Name	2D GS1 DataBar: Set The maximum width of the 2D GS1DataBar Expanded Stacked
Code	ASCII GS ( k pL pH cn fn nL nH Hex. 1D 28 6B pL pH cn fn nL nH Decimal 29 40 107 pL pH cn fn nL nH
Defined Region	pL = 4, pH = 0 cn = 51 fn = 71 $106 \leq n \leq 3952$
Initial Value	$(nL + nH \times 256) = 141$ (nL = 141, nH = 0)
Function	The maximum width of the 2D GS1DataBar Expanded Stacked is set to n dots.
Note	The setting for this function affects the processing of function 381. This setting is enabled until ESC@ is executed, the printer is reset, or the power is turned off. The set unit is 1 dot. The width is set as 0.125 mm (1/203 inches).
Reference	GS ( k Function 381, ESC @

**<Function 380> GS ( k pL pH cn fn m n d1...dk (cn=51, fn=80)**

Name 2D GS1 DataBar: Store data in symbol saving region

Code ASCII GS ( k pL pH cn fn m n d1...dk  
 Hex. 1D 28 6B pL pH cn fn m n d1...dk  
 Decimal 29 40 107 pL pH cn fn m n d1...dk

Defined Region  $4 \leq (pL + pH \times 256) \leq 259$  ( $0 \leq pL \leq 255$ ,  $pH = 0, 1$ )

cn = 51  
 fn = 80  
 m = 48  
 n = 72, 73, 76  
 $0 \leq d \leq 255$   
 $k = (pL + pH \times 256) - 4$

Function Symbol data (d1...dk) for the 2D GS1 DataBar is stored in the symbol saving region.

n	Type of Symbol	Data (k)	ASCII	Data (d)
72	GS1 Databar Stacked	k = 13	"0"to"9"	$48 \leq d \leq 57$
73	GS1 Databar Stacked Omnidirectional	k = 13	"0"to"9"	$48 \leq d \leq 57$
76	GS1 Databar Expanded Stacked	$2 \leq k \leq 255$	0~9, A~Z, a~z SP, !, ", %, \$, ', (, ), *, +, ,, -, ., /, :, ;, <, =, >, ?, _, {	$48 \leq d \leq 57, 65 \leq d \leq 90, 97 \leq d \leq 122,$ $32 \leq d \leq 34, 37 \leq d \leq 47, 58 \leq d \leq 63,$ $d = 95, 123$ [However $d1 = 40, 48 \leq d2 \leq 57, 48 \leq d3 \leq 57, 48 \leq d1 \leq 57, 48 \leq d2 \leq 57$ ]

Note Data stored in the symbol saving region by this function is processed using function 381.  
 After processing functions 381 and 382, data in the saving region is maintained.  
 k bytes for d1...dk are processed as symbol data.  
 This setting is valid until this function is reset, ESC@ is executed, the printer is reset, or the power is off.

Reference GS ( k Function 381, ESC @

**<Function 381> GS ( k pL pH cn fn m (cn=51, fn=81)**

Name	2D GS1 DataBar: Print symbol data of symbol saving region
Code	ASCII GS ( k pL pH cn fn m Hex. 1D 28 6B pL pH cn fn m Decimal 29 40 107 pL pH cn fn m
Defined Region	pL = 3, pH = 0 cn = 51 fn = 81 m = 48
Function	Executes encoding and printing of the symbol data stored in the symbol saving region by GS ( k function 380.
Note	The user must secure the quiet zone.
Reference	GS ( k Function 380
Function	This command prints bar code data or deploys it to the image buffer. This command is ignored when one of the following errors occurs: <ul style="list-style-type: none"> <li>- Error that occurs when the bar code is generated due to the combination of each barcode setting command.</li> <li>- When the generated bar code data exceeds the printable size for the GS1 DataBar.</li> <li>- When the print data exceeds the current set print area.</li> </ul> Make sure you check the printed bar code before actual use.
	For standard mode: <ul style="list-style-type: none"> <li>- If unprinted data still exists in the line buffer, the buffered data is printed out, the command is executed, and then the bar code is printed. Therefore, you cannot print mixed data (characters, bit images, bar codes) on the same line.</li> </ul> For page mode: <ul style="list-style-type: none"> <li>- This command only deploys bar code data to the image buffer.</li> </ul>



**<Function 467> GS ( k pL pH cn fn n (cn=52, fn=67)**

Name	Compound symbol: Set module siz
Code	ASCII GS ( k pL pH cn fn n Hex. 1D 28 6B pL pH cn fn n Decimal 29 40 107 pL pH cn fn n
Defined Region	pL = 3, pH = 0 cn = 52 fn = 67 $2 \leq n \leq 8$
Initial Value	n = 2
Function	The width of one module for compound symbols is set to n dots.
Note	The setting for this function affects the processing of function 481. This setting is enabled until ESC@ is executed, the printer is reset, or the power is turned off. The set unit is 1 dot. The width is set as 0.125 mm (1/203 inches).
Reference	GS ( k Function 481, ESC @

**<Function 471> GS ( k pL pH cn fn nL nH (cn=52, fn=71)**

Name	Compound symbol: Set The maximum width of the 2D GS1DataBar Expanded Stacked
Code	ASCII GS ( k pL pH cn fn nL nH Hex. 1D 28 6B pL pH cn fn nL nH Decimal 29 40 107 pL pH cn fn nL nH
Defined Region	pL = 4, pH = 0 cn = 52 fn = 71 $106 \leq n \leq 3952$
Initial Value	$(nL + nH \times 256) = 141$ (nL = 141, nH = 0)
Function	The maximum width of the GS1DataBar Expanded Stacked in compound symbols is set to n dots.
Note	The setting for this function affects the processing of function 481. This setting is enabled until ESC@ is executed, the printer is reset, or the power is turned off. The set unit is 1 dot. The width is set as 0.125 mm (1/203 inches).
Reference	GS ( k Function 481, ESC @

**<Function 472> GS ( k pL pH cn fn n (cn=52, fn=72)**

Name Compound symbol: Store data in symbol saving region

Code ASCII GS ( k pL pH cn fn n  
 Hex. 1D 28 6B pL pH cn fn n  
 Decimal 29 40 107 pL pH cn fn n

Defined Region pL = 3, pH = 0  
 cn = 52  
 fn = 72  
 $0 \leq n \leq 2, 48 \leq n \leq 50$

Initial Value n = 0

Function Select the font for HRI characters when printing combined symbols.

n	HRI font
0,48	not printed
1,49	printed (Select font A(12x24))
2,50	printed (Select font B(9x17))

Note Data stored in the symbol saving region by this function is processed using function 481.

When "Print" HRI is selected, HRI is printed under 1D bar codes.

When the combined symbol uses a 2D code (GS1 DataBar Stacked, GS1 DataBar Stacked Omnidirectional, GS1 DataBar Expanded Stacked), this setting is not affected and HRI is not printed.

This setting is valid until this function is reset, ESC@ is executed, the printer is reset, or the power is off.

Reference GS ( k Function 481, ESC @

**<Function 480> GS ( k pL pH cn fn m a b d1...dk (cn=52, fn=80)**

Name	Compound symbol: Store data in symbol saving region
Code	ASCII GS ( k pL pH cn fn m a b d1...dk Hex. 1D 28 6B pL pH cn fn m a b d1...dk Decimal 29 40 107 pL pH cn fn m a b d1...dk
Defined Region	$7 \leq (pL+pH \times 256) \leq 2366$ ( $0 \leq pL \leq 255, 0 \leq pH \leq 9$ ) cn = 52 fn = 80 m = 48 a = 48,49 $65 \leq b \leq 77$ (a=48) b = 65,66 (a=49) $0 \leq d \leq 255$ $k = (pL+pH \times 256) - 5$
Function	Symbol data (d1...dk) for the Compound symbol:is stored in the symbol saving region.

a = 48

b	Bar Code Type	Data (k)	ASCII	Defined region of d
65	EAN8	k = 7,8	"0"to"9"	$48 \leq d \leq 57$
66	EAN13	k = 12,13	"0"to"9"	$48 \leq d \leq 57$
67	UPC-A	k = 11,12	"0"to"9"	$48 \leq d \leq 57$
69	UPC-E (11-digit version (0 included))	k = 11,12	"0"to"9"	$48 \leq d \leq 57$
70	GS1 DataBar	k = 13	"0"to"9"	$48 \leq d \leq 57$
71	GS1 DataBar Truncated	k = 13	"0"to"9"	$48 \leq d \leq 57$
72	GS1 DataBar Stacked	k = 13	"0"to"9"	$48 \leq d \leq 57$
73	GS1 DataBar Stacked Omnidirectional	k = 13	"0"to"9"	$48 \leq d \leq 57$
74	GS1 DataBar Limited	k = 13	"0"to"9"	$48 \leq d \leq 57$ [However d1 = 48,49]
75	GS1 DataBar Expanded	$2 \leq k \leq 255$	0~9, A~Z, a~z SP, !, ", %, \$, ' , ( , ) , * , + , , , - , , / , : , ; , < , = , > , ? , _ , {	$48 \leq d \leq 57, 65 \leq d \leq 90, 97 \leq d \leq 122,$ $32 \leq d \leq 34, 37 \leq d \leq 47, 58 \leq d \leq 63,$ d = 95,123 [However d1 = 40, $48 \leq d2 \leq 57, 48 \leq d3 \leq 57, 48 \leq d1 \leq 57, 48 \leq d2 \leq 57$ ]
76	GS1 DataBar Expanded Stacked	$2 \leq k \leq 255$	0~9, A~Z, a~z SP, !, ", %, \$, ' , ( , ) , * , + , , , - , , / , : , ; , < , = , > , ? , _ , {	$48 \leq d \leq 57, 65 \leq d \leq 90, 97 \leq d \leq 122,$ $32 \leq d \leq 34, 37 \leq d \leq 47, 58 \leq d \leq 63,$ d = 95,123 [However d1 = 40, $48 \leq d2 \leq 57, 48 \leq d3 \leq 57, 48 \leq d1 \leq 57, 48 \leq d2 \leq 57$ ]
77	GS1-128	$2 \leq k \leq 255$		$0 \leq d \leq 127$

a = 49

b	Type of Symbol	Data (k)	Data (d)
65	CC-A, CC-B, CC-C Automatic distinction by a digit number.	$3 \leq k \leq 2361$	$32 \leq d \leq 127$
66	fixing to CC-C	$3 \leq k \leq 2361$	$32 \leq d \leq 127$

Note                      Data stored in the symbol saving region by this function is processed using function 481.  
 After processing functions 481, data in the saving region is maintained.  
 k bytes for d1...dk are processed as symbol data.  
 This setting is valid until this function is reset, ESC@ is executed, the printer is reset, or the power is off.

Reference                GS ( k Function 481, ESC @

**<Function 481> GS ( k pL pH cn fn m (cn=52, fn=81)**

Name	Compound symbol: Store data in symbol saving region
Code	ASCII GS ( k pL pH cn fn m Hex. 1D 28 6B pL pH cn fn m Decimal 29 40 107 pL pH cn fn m
Defined Region	pL = 3, pH = 0 cn = 52 fn = 81 m = 48
Function	Executes encoding and printing of the symbol data stored in the symbol saving region by GS ( k function 480. The user must secure the quiet zone.
Reference	GS ( k Function 480
Function	This command prints bar code data or deploys it to the image buffer. This command is ignored when one of the following errors occurs: <ul style="list-style-type: none"> <li>- Error that occurs when the bar code is generated due to the combination of each barcode setting command.</li> <li>- When the generated bar code data exceeds the printable size for the GS1 DataBar.</li> <li>- When the print data exceeds the current set print area.</li> </ul> Make sure you check the printed bar code before actual use.
	For standard mode: <ul style="list-style-type: none"> <li>- If unprinted data still exists in the line buffer, the buffered data is printed out, the command is executed, and then the bar code is printed. Therefore, you cannot print mixed data (characters, bit images, bar codes) on the same line.</li> </ul> For page mode: <ul style="list-style-type: none"> <li>- This command only deploys bar code data to the image buffer.</li> </ul>

**GS / m**

Name Print download bit images

Code ASCII GS / m  
 Hex. 1D 2F m  
 Decimal 29 47 m

Defined Region  $0 \leq m \leq 3, 48 \leq m \leq 51$

Function Prints defined download bit image data using mode m.

m	Print Mode	Density of Vertical Direction Dots	Density of Horizontal Direction Dots
0, 48	Normal Mode	180 DPI	180 DPI
1, 49	Double-wide Mode	180 DPI	90 DPI
2, 50	Double-tall Mode	90 DPI	180 DPI
3, 51	Quadruple Mode	90 DPI	90 DPI

**Details**

- This command is ignored if there is no download bit image data defined.
- This command is effective only when no data exists in the print buffer in standard mode.
- Excluding upside-down printing, print modes (emphasized printing, overlap printing, underlines, character sizes and black/white inverted printing) are unaffected.
- If there is download bit image data defined that exceeds the print region, that excess portion is not printed.
- Regardless of the line feed amount set by ESC 2 (Initial line feed amount setting) and ESC 3 (Line feed amount setting), a paper feed is executed for the amount of dots (the height of the download bit image n) when in normal mode and horizontal double wide mode, and for the amount of dots (the height of the download bit image n x 2) when in double high mode and double wide double high mode.
- See section 2.3.2 for details on the download bit image expansion position in page mode.

**STAR**

- Dot density (when the STAR printer head = 203 DPI) on STAR printers.

m	Mode	Density of Vertical Direction Dots	Density of Horizontal Direction Dots
0, 48	Normal Mode	203 DPI	203 DPI
1, 49	Double-wide Mode	203 DPI	101 DPI
2, 50	Double-tall Mode	101 DPI	203 DPI
3, 51	Quadruple Mode	101 DPI	101 DPI

Reference GS \*

**GS:**

Name	Start/execute macro definition
Code	ASCII      GS      : Hex.        1D    3A Decimal     29    58
Function	Starts and stops macro definition.
Details	<ul style="list-style-type: none"> <li>• If this command is input during normal operation, the macro definition is started.</li> <li>• If this command is input while defining a macro, the macro definition is stopped.</li> <li>• If GS ^ (Execute macro definition) is input while defining a macro, the macro definition is cancelled and the contents are cleared.</li> <li>• The initial status of the macro is undefined.</li> <li>• The contents of the definition are not cleared by ESC @ (Initialize printer).</li> <li>• The macro enters an undefined status if GS: is input immediately after inputting GS:.</li> <li>• The data count that can be defined in a macro is 2048 bytes. Data that exceeds 2048 bytes is not defined.</li> </ul>
STAR	<ul style="list-style-type: none"> <li>• Operators should be aware that if the raster graphic command (GS v) is inserted into the data while defining a macro, the macro definition is immediately ended as being undefined and the printer enters a raster graphics process.</li> </ul>
Reference	GS ^

**GS B n**

Name	Specify/cancel white/black inverted printing			
Code	ASCII	GS	B	n
	Hex.	1D	42	n
	Decimal	29	66	n
Defined Region	$0 \leq n \leq 255$			
Initial Value	n = 0			
Function	Specifies or cancels black and white inverted printing.			
	<ul style="list-style-type: none"> <li>• Cancels black and white inverted printing when n = &lt;*****0&gt;B.</li> <li>• Specifies black and white inverted printing when n = &lt;*****1&gt;B.</li> </ul>			
Details	<ul style="list-style-type: none"> <li>• n is effective only when it is the lowest bit.</li> <li>• Internal characters and download characters are targeted for black and white inverted printing.</li> <li>• The right space of set characters set by ESC SP (Set character right space amount) is also targeted for black and white inverted printing.</li> <li>• The following are not targeted for black and white inverted printing.               <ul style="list-style-type: none"> <li>a. ESC* : Bit image</li> <li>b. GS / : Download bit image</li> <li>c. GS k : Bar code</li> <li>d. GS H : HRI Characters</li> <li>e. HT : Skipped portion by horizontal tab</li> <li>f. ESC \$ : Skipped portion by specification of vertical position</li> <li>g. ESC \ : Skipped portion by specification of relative position</li> </ul> </li> <li>• This does not affect the line spacing.</li> <li>• Black and white inverted printing has priority over underlines. Therefore, the inverted characters are not underlined, even if underline is specified. However, the underline setting status does not change.</li> <li>• This command is effective for ANK and Chinese characters.</li> </ul>			



**GS C 0 n m**

Name	Set counter print mode					
Code	ASCII	GS	C	0	n	m
	Hex.	1D	43	30	n	m
	Decimal	29	67	48	n	m
Defined Region	$0 \leq n \leq 5$					
	$0 \leq m \leq 2, 48 \leq m \leq 50$					
Initial Value	n = 0					
	m = 0					
Function	Sets the serial number counter print mode.					

m	Printing Position	Processing of Counter Value Less than Set Digit Count
0, 48	Align Right	Applies a space to the left side
1, 49	Align Right	Applies a 0 to the left side
2, 50	Align Left	Applies a space to the right side

- Details
- n specifies the digits to print.
  - When n = 0, the printer prints only the actual number of digits of the counter value.
  - Sets the print digit count when n ≠ 0.
  - m sets the serial number counter printing position in the set digit count.
  - If the counter value is larger than the n set digit count, the printer prints n digits below the counter value.

<n = 3, m = 0>

ΔΔ1

<n = 3, m = 1>

001

<n = 3, m = 2>

1ΔΔ

Δ=Space

Reference GS C 1, GS C 2, GSC ;, GS c

**GS C 1 aL aH bL bH n r**

Name	Set Counter Mode (A)										
Code	ASCII	GS	C	1	aL	aH	bL	bH	n	r	
	Hex.	1D	43	31	aL	aH	bL	bH	n	r	
	Decimal	29	67	49	aL	aH	bL	bH	n	r	
Defined Region	$0 \leq aL \leq 255$										
	$0 \leq aH \leq 255$										
	$0 \leq bL \leq 255$										
	$0 \leq bH \leq 255$										
	$0 \leq n \leq 255$										
	$0 \leq r \leq 255$										
Initial Value	aL = 1, aH = 0										
	bL = 255, bH = 255										
	n = 0										
	r = 1										
Function	Sets the counter mode for the serial counter.										
Details	<ul style="list-style-type: none"> <li>• aL, aH and bL, bH specify the counter range.</li> <li>• n specifies the number of steps to count up or down.</li> <li>• r specifies the number of times to repeat printing with the counter value fixed.</li> <li>• If <math>\{(aL + aH \times 256) &lt; (bL + bH \times 256) \text{ and } n \neq 0 \text{ and } r \neq 0\}</math> this command sets the count up mode.</li> <li>• If <math>\{(aL + aH \times 256) &gt; (bL + bH \times 256) \text{ and } n \neq 0 \text{ and } r \neq 0\}</math> this command sets the count down mode.</li> <li>• If <math>\{(aL + aH \times 256) = (bL + bH \times 256) \text{ and } n = 0 \text{ and } r = 0\}</math> this command stops counting.</li> <li>• When the count up mode is set, <math>(aL + aH \times 256)</math> is the counter minimum value and <math>(bL + bH \times 256)</math> is the counter maximum value.</li> </ul> <p>Also, if the counter exceeds the maximum value, it starts counting up again from the minimum value.</p> <ul style="list-style-type: none"> <li>• When the count down mode is set, <math>(aL + aH \times 256)</math> is the counter maximum value and <math>(bL + bH \times 256)</math> is the counter minimum value.</li> </ul> <p>Also, if the counter is smaller than the minimum value, it starts counting down again from the maximum value.</p> <ul style="list-style-type: none"> <li>• Executing this command clears the internal counter that shows the number of times printing was repeated.</li> </ul>										
	Reference	GS C 0, GS C 2, GS C ; , GS c									

**GS C 2 nL nH**

Name	Set counter mode value					
Code	ASCII	GS	C	2	nL	nH
	Hex.	1D	43	32	nL	nH
	Decimal	29	67	50	nL	nH
Defined Region	$0 \leq nL \leq 255$					
	$0 \leq nH \leq 255$					
Initial Value	nL = 1, nH = 0					
Function	Sets the serial number counter value.					
Details	<ul style="list-style-type: none"> <li>• nL and nH set the counter value.</li> <li>• In the count up mode, if the counter value specified by this command goes out of the counter operating range, specified by GSC1 or GSC;, it is forced to convert to the minimum value by the next GSc.</li> <li>• In the count down mode, if the counter value specified by this command goes out of the counter operating range, specified by GSC1 or GSC;, it is forced to convert to the maximum value by the next GSc.</li> </ul>					
Reference	GS C 0, GS C 1, GS C ; , GS c					

**GS C ; sa; sb; sn; sr; sc;**

Name	Set Counter Mode (B)
Code	ASCII    GS    C    ;    sa    ;    sb    ;    sn    ;    sr    ;    sc    ; Hex.        1D  43  3B  sa  3B  sb  3B  sn  3B  sr  3B  sc  3B Decimal     29  67  59  sa  59  sb  59  sn  59  sr  59  sc  59
Defined Region	"0" ≤ sa ≤ "65535" "0" ≤ sb ≤ "65535" "0" ≤ sn ≤ "255" "0" ≤ sr ≤ "255" "0" ≤ sc ≤ "65535"
Initial Value	sa = "1" sb = "65535" sn = "0" sr = "1" sc = "1"
Function	Sets the serial number counter counting mode and counter value.
Details	<ul style="list-style-type: none"> <li>• sa, sb, sn, sr and sc are all ASCII character strings represent setting values using decimals. They are composed of character strings of 0 to 9.</li> <li>• sa, and sb specify the counter range.</li> <li>• sn specifies the number of steps to count up or down.</li> <li>• sr specifies the number of times to repeat printing with the counter value fixed.</li> <li>• sc specifies the counter value.</li> <li>• If {sa &lt; sb and sn ≠ 0 and sr ≠ 0} this command sets the count up mode.</li> <li>• If {sa &gt; sb and sn ≠ 0 and sr ≠ 0} this command sets the counter down mode.</li> <li>• If {sa = sb or n = 0 and sr = 0} this command stops counting.</li> <li>• When the count up mode is set, sa is the counter minimum value and sb is the counter maximum value. Also, if the counter exceeds the maximum value, it starts counting again from the minimum value.</li> <li>• When the count down mode is set, sa is the counter maximum value and sb is the counter minimum value. Also, if the counter is smaller than the minimum value, it starts counting down again from the maximum value.</li> <li>• Each argument from sa to sc can be omitted. The setting just prior is maintained without change to the setting value that corresponds to the omitted argument.</li> <li>• Executing this command clears the internal counter that shows the number of times printing was repeated.</li> <li>• If an argument outside of the definition region is input, the command is stopped and processing is handled normally from subsequent data.</li> </ul>
Reference	GS C 0, GS C 1, GS C 2, GS c

**GS E n**

Name	Set printing speed			
Code	ASCII	GS	E	n
	Hex.	1D	45	n
	Decimal	29	69	n
Defined Region	$0 \leq n \leq 255$			
Initial Value	n = 0			
Function	Sets print speed.			

Bit	Function	"0"	"1"
7	Undefined	--	--
6	Undefined	--	--
5	Print Speed	(See table below)	
4			
3	Undefined	--	--
2	Undefined	--	--
1	Undefined	--	--
0	Undefined	--	--

**Spec. A**  
 Print Speed

Bit-5	Bit-4	Print Speed
0	0	High speed
0	1	Mid-speed
1	0	Slow speed
1	1	Undefined

**Spec. B**  
 Print Speed

Bit-5	Bit-4	Print Speed
0	0	High speed
0	1	Undefined
1	0	Slow speed
1	1	Undefined

**Details**

- This command is effective in standard mode.
- This command is enabled only when at the top of the line.
- The speed setting is disabled during reduced printing in the vertical direction. However, this command setting is enabled when reduced printing in the vertical direction is released.

**STAR**

- This command changes the print speed after the test print is stopped.

**GS H n**

Name                    Select HRI character print position

Code	ASCII	GS	H	n
	Hex.	1D	48	n
	Decimal	29	72	n

Defined Region     $0 \leq n \leq 3, 48 \leq n \leq 51$

Initial Value        n = 0

Function             Selects the printing position of HRI characters when printing bar codes.

n	Printing Position
0, 48	No print
1, 49	Above bar code
2, 50	Below bar code
3, 51	Above and below bar code (both)

Details                • HRI is an acronym for Human Readable Interpretation.  
                               • HRI characters are printed with fonts selected by GS f (Select HRI character font).

Reference             GS f, GS k

**GS In**

Name Transmission of Printer ID

 Code ASCII GS I n  
 Hex. 1D 49 n  
 Decimal 29 73 n

 Defined Region Spec. A  $1 \leq n \leq 3, 49 \leq n \leq 51, 65 \leq n \leq 69$   
 Spec. B  $1 \leq n \leq 4, 49 \leq n \leq 51, 65 \leq n \leq 69, 111 \leq n \leq 113$ 

Function Sends the specified printer ID.

## Spec. A

n	Printer ID Type	Specifications
1, 49	Model ID	TM-T88II = 0 x 20 BA-T500 = 0 x 27
2, 50	Type ID	(See table below; Type ID)
3, 51	ROM Version ID	Depends on the ROM version

## Spec. B

n	Printer ID Type	Specifications
1, 49	Model ID	See the models below.
2, 50	Type ID	(See <Type ID> in the table below.)
3, 51	ROM version ID	Depends on the ROM version
65	Firmware Version	Depends on the Firmware Version
66	Manufacturers Name	STAR
67	Model Name	See the models below.
68	Serial Number	"0000000000000000"
69	Double bytes Character Type	Japanese Kanji : KANJI JAPANESE Chinese Character : CHINA GB2312 or CHINA GB18030 Taiwan Chinese Character : TAIWAN BIG-5

## &lt;Type ID&gt;

Bit	Function	"0"	"1"
7	Fixed at "0"		
6	Undefined	---	---
5	Undefined	---	---
4	Fixed at "0"		
3	MICR Reader	None	Yes
2	Direct connection to customer display	None	Yes
1	Auto-cutter	None	Yes
0	2 Byte Code Handling	None	Yes

## Details

- If using DTR/DSR control when using a serial interface, the printer sends its ID after it has verified that the host has entered a data ready state (the DSR signal is a space). If the host is not able to receive data (DSR signal is a mark), the printer will wait until it is ready.

The using XON/XOFF control, the printer transmits its ID without verifying whether the host can receive data.

- Because this command is executed while expanding the print buffer, there may be a delay between the reception of the command and printer ID transmission, depending on the reception buffer status.
- ( $1 \leq n \leq 3$ ,  $49 \leq n \leq 51$ ) sends 1 byte of the printer ID.
- When ASB is enabled, the printer ID transmitted by this command and the ASB status must be differentiated. See Appendix-2 for details on how to identify.
- ( $65 \leq n \leq 69$ ) sends the following printer information.

Header: Hex. = 5FH/Decimal = 95 (1 byte)

Data: Printer Information

NUL: Hex. = 00H/Decimal = 0 (1 byte)

- The following processes occur when preparations for transmitting data have been completed.

1. Executes a READY to BUSY process If the printer is already in a BUSY state, the printer does nothing.
2. Executes the [Header + Data + NUL] transmission
3. Executes a BUSY to READY process If the printer is already in a BUSY state for some other reason, it does nothing.

## STAR

Spec. A: STAR printers ignore this command if  $65 \leq n \leq 69$  is specified.

## Reference

See Appendix -2 for details.



**GS L nL nH**

Name	Set left margin				
Code	ASCII	GS	L	nL	nH
	Hex.	1D	4C	nL	nH
	Decimal	29	76	nL	nH
Defined Region	$0 \leq nL \leq 255$				
	$0 \leq nH \leq 255$				
Initial Value	nL = 0, nH = 0				
Function	• nL and nH set the specified left margin.				
	• The left margin is $[(nL + nH \times 256) \times \text{basic calculated pitch}]$				

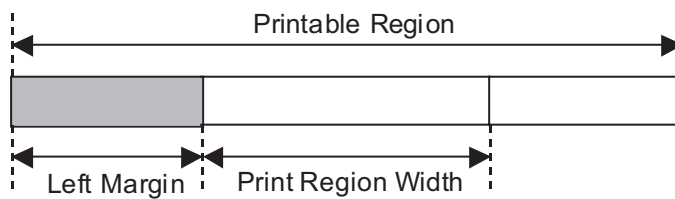

Details	<ul style="list-style-type: none"> <li>• This command is effective only when input at the top of the line when standard mode is being used.</li> <li>• This command has no affect in page mode. This command is only effective for the setting.</li> <li>• The maximum setting for the left margin is the same size as the printable region for the horizontal direction. Specifications that exceed the maximum value are rounded off to that value.</li> <li>• The basic calculated pitch is set by GSP (Set basic calculated pitch). Also, after setting the left margin, it is not affected even if the basic calculated pitch is changed.</li> <li>• Use the basic calculated pitch (x) for the horizontal direction of GS P (Set basic calculated pitch) to calculate the left margin. If the calculation results in fractions, the pitch is corrected to a minimal mechanical pitch and the rest is discarded.</li> <li>• See Appendix-4 for setting details.</li> </ul>
	Reference

## GS P x y

Name	Set basic calculation pitch				
Code	ASCII	GS	P	x	y
	Hex.	1D	50	x	y
	Decimal	29	80	x	y
Defined Region	$0 \leq x \leq 255$				
	$0 \leq y \leq 255$				
Initial Value	x = 180, y = 360				
Function	<p>Sets the horizontal direction basic calculation pitch to approximately 25.4 [(1/x) inch] and the vertical direction basic calculation pitch to approximately 25.4 [(1/y) inch].</p> <ul style="list-style-type: none"> <li>• When x = 0, the horizontal direction basic calculation pitch is returned to its initial value.</li> <li>• When y = 0, the vertical direction basic calculation pitch is returned to its initial value.</li> </ul>				
Details	<p>The horizontal direction indicates a direction perpendicular to the paper feed; and the vertical direction indicates the paper feed direction.</p> <ul style="list-style-type: none"> <li>• In standard mode, use the parameter that indicates the following regardless of the character direction (upside down, 90° rotation, etc.).           <ol style="list-style-type: none"> <li>Commands that use x:ESC SP, ESC \$, ESC \, FS S, GS L, GS W</li> <li>Commands that use y:ESC 3, ESC J, GS V</li> </ol> </li> <li>• In page mode, use the parameter that indicates the following according to character direction.           <ol style="list-style-type: none"> <li>When starting point is upper left or lower right by ESC T (Selection of character print direction in page mode):               <p>Commands that use x:ESC SP, ESC \$, ESC W, ESC \, FS S</p> <p>Commands that use y:ESC 3, ESC J, ESC W, GS \$, GS \, GS V</p> </li> <li>When starting point is upper right or lower left by ESC T (Selection of character print direction in page mode):               <p>Commands that use x:ESC 3, ESC J, ESC W, GS \$, GS \</p> <p>Commands that use y:ESC SP, ESC \$, ESC W, ESC \, FS S, GS V</p> </li> </ol> </li> <li>• Each set value is unaffected even if this command is executed.</li> <li>• If there is a fraction in the result of the calculation when combined with another command, it is corrected with the minimum mechanical pitch, and the remainder is discarded.</li> </ul>				
STAR	<p>To improve the difference in distance calculations that are generated by the difference in print density (Star = 203 DPI/Epson = 180 DPI) with the installed print head, Star printers have a “basic calculation pitch correction”. By setting this to 203 DPI, it corrects the value calculated using the basic calculation pitch such as ESC \$ (Move to absolute position), and GS L (Left margin) to enable the same distance of movement as an Epson printer.</p> <p>However, data such as fonts and bit images cannot be corrected with basic calculation pitch correction.</p> <ul style="list-style-type: none"> <li>• Basic calculation pitch correction: 203DPI or 180DPI</li> <li>• Basic calculation pitch correction when left margin is specified           <ul style="list-style-type: none"> <li>• Basic calculation pitch: X Y</li> <li>• Left margin specification value: nL nH</li> </ul> </li> </ul>				

(1) When basic calculation pitch correction has selected 203 DPI

Left margin =  $(nL + nH \times 256) \times 2032/X/10$ (Decimals are discarded.)

(2) When basic calculation pitch correction has selected 180 DPI

Left margin =  $(nL + nH \times 256) \times 180/X$ (Decimals are discarded.)

Reference ESC SP, ESC \$, ESC 3, ESC J, ESC W, ESC \, GS \$, GS L GS V, GS W, GS \

GS T n

Name Move to top of line

Code ASCII GS T n  
 Hex. 1D 54 n  
 Decimal 29 84 n

Defined Region n = 0,1,48,49

Function Moves print position to top of line.

- This command is effective only in standard mode. It is ignored in page mode.

n	Function
0, 48	After erasing data in the printer buffer, it moves the print position.
1, 49	After printing data in the printer buffer, it moves the print position.

**GS V m**

Name	Cut paper			
Code	ASCII	GS	V	m
	Hex.	1D	56	m
	Decimal	29	86	m
Defined Region	m = 0,1,48,49			
Function	Executes specified paper cut.			

m	Function
0, 48	Full cut
1, 49	Partial cut (one point uncut)
2, 50	Not Used
3, 51	Not Used
65	Feeds paper to (cutting position + [n x basic calculated pitch]) and performs a full cut
66	Feeds paper to (cutting position + [n x basic calculated pitch]) and performs a partial cut (one point uncut)
67	Not Used
68	Not Used

Details	<ul style="list-style-type: none"> <li>• This command is effective only when processed at the top of the line when standard mode is being used.</li> <li>• Cuts paper.</li> </ul>
STAR	<ul style="list-style-type: none"> <li>• The auto-cut function differs according to the model. A partial cut is executed on those models that cannot perform a full cut.</li> </ul> <p>A full cut is executed on those models that cannot perform a partial cut. Refer to the product specifications manual for the specifications of the auto-cut function.</p> <ul style="list-style-type: none"> <li>• Models that do not have the auto-cut function do not cut paper. However, commands that accompany a paper feed of (cutting position + [n x basic calculated pitch]) (n = 65, 66), a paper feed of (tear bar position + [n x basic calculated pitch]) is executed.</li> </ul>
Reference	ESC i, ESC m

**GS V m n**

Name	Cut paper				
Code	ASCII	GS	V	m	n
	Hex.	1D	56	m	n
	Decimal	29	86	m	n
Defined Region	m = 65, 66, 0 ≤ n ≤ 255				
Function	Executes specified paper cut.				

m	Function
0, 48	Full cut
1, 49	Partial cut (one point uncut)
2, 50	Not Used
3, 51	Not Used
65	Feeds paper to (cutting position + [n x basic calculated pitch]) and performs a full cut
66	Feeds paper to (cutting position + [n x basic calculated pitch]) and performs a partial cut (one point uncut)
67	Not Used
68	Not Used

Details	<ul style="list-style-type: none"> <li>• This command is effective only when processed at the top of the line when standard mode is being used.</li> <li>• Feeds paper to the cutting position when n = 0, then cuts the paper.</li> <li>• Feeds paper [n x basic calculated pitch] beyond the cutting position when n ≠ 0, then cuts the paper.</li> <li>• The basic calculated pitch is set by GSP (Set basic calculated pitch).</li> <li>• Use the basic calculated pitch (y) relating to the vertical direction for the paper feed amount. If the calculation results in fractions, the pitch is corrected to a minimal mechanical pitch and the rest is discarded.</li> </ul>
STAR	<ul style="list-style-type: none"> <li>• The auto-cut function differs according to the model. A partial cut is executed on those models that cannot perform a full cut. A full cut is executed on those models that cannot perform a partial cut. Refer to the product specifications manual for the specifications of the auto-cut function.</li> <li>• Models that do not have the auto-cut function do not cut paper. However, commands that accompany a paper feed of (cutting position + [n x basic calculated pitch]) (n = 65, 66), a paper feed of (tear bar position + [n x basic calculated pitch]) is executed.</li> </ul>
Reference	ESC i, ESC m

**GS W nL nH**

Name	Set print region width				
Code	ASCII	GS	W	nL	nH
	Hex.	1D	57	nL	nH
	Decimal	29	87	nL	nH
Defined Region	$0 \leq nL \leq 255$				
	$0 \leq nH \leq 255$				
Initial Value	See the Appendix -4				
Function	<ul style="list-style-type: none"> <li>• Sets the print region width specified by nL and nH.</li> <li>• Print region width is <math>[(nL + nH \times 256) \times \text{basic calculated pitch}]</math>.</li> </ul>				

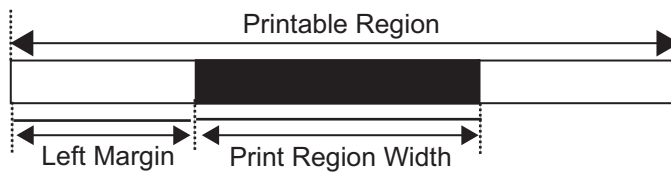

Details	<ul style="list-style-type: none"> <li>• This command is effective only when processed at the top of the line when standard mode is being used.</li> <li>• This command has no affect on page mode when in page mode. Only the setting is effective for this command.</li> <li>• When a value that exceeds the printable region of one line, the entire region, excluding the left margin, is set as the print region width.</li> <li>• The basic calculated pitch is set by GSP (Set basic calculated pitch). Also, the set printing region width is not changed even if the basic calculated pitch is changed after setting the print region width.</li> <li>• Use the basic calculated pitch (x) for the horizontal direction of GS P (Set basic calculated pitch) to calculate the print region width. If the calculation results in fractions, the pitch is corrected to a minimal mechanical pitch and the rest is discarded.</li> <li>• If the print region width is smaller than the width of the first character expanded at the top of the line (including the right space), the following are processed only on that line. <ol style="list-style-type: none"> <li>1. The print region is expanded to the right for the size of that character within the range that does not exceed the printable region.</li> <li>2. If there is not enough space even if 1. is executed, the print region is expanded to the left side.</li> <li>3. If there is not enough space even if 2. is executed, the right space deleted.</li> </ol> </li> <li>• See Appendix-4 for setting details.</li> </ul>
Reference	GS L, GS P, Appendix -4

**GS \ nL nH**

Name	Specify relative position for character vertical direction in page mode															
Code	<table border="0"> <tr> <td>ASCII</td> <td>GS</td> <td>\</td> <td>nL</td> <td>nH</td> </tr> <tr> <td>Hex.</td> <td>1D</td> <td>5C</td> <td>nL</td> <td>nH</td> </tr> <tr> <td>Decimal</td> <td>29</td> <td>92</td> <td>nL</td> <td>nH</td> </tr> </table>	ASCII	GS	\	nL	nH	Hex.	1D	5C	nL	nH	Decimal	29	92	nL	nH
ASCII	GS	\	nL	nH												
Hex.	1D	5C	nL	nH												
Decimal	29	92	nL	nH												
Defined Region	$0 \leq nL \leq 255$ $0 \leq nH \leq 255$															
Function	<ul style="list-style-type: none"> <li>Specifies the character vertical direction position for the data expansion starting position using the relative position based on the current point in page mode. This sets the position moved from the current position to <math>[(nL + nH \times 256) \times \text{basic calculated pitch}]</math> for the next data expanding starting position.</li> </ul>															
Details	<ul style="list-style-type: none"> <li>When not in page mode, this command is ignored.</li> <li>If the direction below the current position is specified for the characters, specify a positive number; if the direction above is specified, a negative number is used.</li> <li>Negative numbers are represented by the complement of 65536. For example, when moving in the upward direction N pitches, use:  <math>nL + nH \times 256 = 65536 - N</math> </li> <li>Specifications for relative positions that exceed the specified print region are ignored.</li> <li>The following operations occur depending on ESC T (Selecting the character printing direction in page mode).             <ol style="list-style-type: none"> <li>If the starting point is upper left or lower right, specify the relative position for the paper feed direction. Use the basic calculated pitch (y) for the horizontal direction at this time.</li> <li>If the starting point is upper right or lower left, specify the relative position for the paper feed in the vertical direction. Use the basic calculated pitch (x) for the horizontal direction at this time.</li> </ol> </li> <li>The basic calculated pitch is set by GSP (Set basic calculated pitch).</li> <li>If the calculation results in fractions, the pitch is corrected to a minimal mechanical pitch and the rest is discarded.</li> </ul>															
Reference	ESC \$, ESC T, ESC W, ESC \, GS \$, GS P															



## GS ^ r t m

Name	Execute macro
Code	ASCII      GS      ^      r      t      m
	Hex.        1D    5E    r    t    m
	Decimal    29    94    r    t    m
Defined Region	$0 \leq r \leq 255$
	$0 \leq t \leq 255$
	$0 \leq m \leq 1$
Function	<ul style="list-style-type: none"> <li>• Executes a defined macro.</li> </ul> <p>r specifies the number of times to execute the macro.</p> <p>t specifies the time to wait when executing the macro.</p> <p>m specifies the macro execution mode.</p> <p>m = 0: Executes the macro continuously the r number of times while interposing time gaps specified by t.</p> <p>m = 1: After an amount of time specified by t, the POWER LED flashes and waits for the paper feed switch to be pressed.</p> <p>The macro is executed once when the paper feed switch is pressed.</p> <p>This operation is repeated the number of times specified by r.</p>
Details	<ul style="list-style-type: none"> <li>• After executing a macro once, the printer waits approximately (t x 100 m) sec according to that specified by t.</li> <li>• When processing this command while defining a macro, the macro definition is terminated and the contents of the definition are cleared.</li> <li>• When a macro is undefined, and r = 0, this command is ignored.</li> <li>• When m = 1, paper is not fed using the paper feed switch while the macro is being executed.</li> </ul>
STAR	<ul style="list-style-type: none"> <li>• If a raster graphic command (GS v) is received while executing a macro on a printer equipped with a parallel interface, the user should be aware that the printer will enter a BUSY state.</li> </ul>
Reference	GS :

**GS b n**

Name	Specify/cancel smoothing			
Code	ASCII	GS	b	n
	Hex.	1D	62	n
	Decimal	29	98	n
Defined Region	$0 \leq n \leq 255$			
Initial Value	n = 0			
Function	Specifies or cancels smoothing.			
	<ul style="list-style-type: none"> <li>• Cancels smoothing when n = &lt;*****0&gt;B.</li> <li>• Specifies smoothing when n = &lt;*****1&gt;B.</li> </ul>			
Details	<ul style="list-style-type: none"> <li>• n is effective only when it is the lowest bit.</li> <li>• Targets for smoothing are: embedded characters, download characters and external characters</li> <li>• Even if smoothing is specified, it will not be performed if the character is set for magnification in either the vertical or horizontal directions.</li> </ul>			
Reference	ESC !, GS !			

**GS c**

Name	Print counter
Code	ASCII      GS    c
	Hex.        1D   63
	Decimal    29   99
Function	After expanding the current serial counter value as print data (a character string) to the print buffer, the printer counts up or counts down according to the count mode.
Details	<ul style="list-style-type: none"> <li>• The counter value expanded to the print buffer the printer prints by either the print instruction or by a print buffer full.</li> <li>• The counter print mode is set by GS C 0.</li> <li>• The counter mode is set by GS C 1, or GS C ;.</li> <li>• In the count up mode, if the counter value specified by this command goes out of the counter operating range, specified by GSC1 or GSC;, it is forced to convert to the minimum value by the execution of this command.</li> <li>• In the count down mode, if the counter value specified by this command goes out of the counter operating range, specified by GSC1 or GSC;, it is forced to convert to the maximum value by the execution of this command.</li> </ul>
Reference	GS C 0, GS C 1, GS 2, GS C ;

**GS f n**

Name                Select HRI character font

Code                ASCII        GS        f        n  
                           Hex.        1D    66        n  
                           Decimal    29  102    n

Defined Region    n = 0,1,48,49

Initial Value      n = 0

Function            Selects the printing position of HRI character font when printing bar codes.

n	Font
0, 48	Selects Font A (12 x 24).
1, 49	Selects Font B (9 x 17).

Details             • HRI is an acronym for Human Readable Interpretation.  
                           • HRI characters are printed in a position specified GS H (Select HRI character print position).

STAR                The following are the HRI character font configurations on STAR printers.

Character Fonts	Horizontal Dots x Vertical Dots
Font A	12 x 24 Dots
Font B	9 x 24 Dots

Reference           GS H, GS k

**GS h n**

Name	Set bar code height			
Code	ASCII	GS	h	n
	Hex.	1D	68	n
	Decimal	29	104	n
Defined Region	$1 \leq n \leq 255$			
Initial Value	n = 162			
Function	Sets bar code height to n dots.			
Reference	GS k			

**1. GS k m d1 ... dk NUL.**
**2.3. GS k m n d1 ... dk**

Name	Print bar code			
Code	1. ASCII	GS	k	md1...dk NUL
	Hex.	1D	6B	md1...dk NUL
	Decimal	29	107	md1...dk NUL
	2.3. ASCII	GS	k	m nd1...dk
	Hex.	1D	6B	m nd1...dk
	Decimal	29	107	m nd1...dk

- Defined Region
- $0 \leq m \leq 6$  The definition region of k and d differ according to the bar code type.
  - $65 \leq m \leq 73$  The definition region of n and d differ according to the bar code type.
  - $65 \leq m \leq 78$  The definition region of n and d differ according to the bar code type.

Function Selects bar code type and prints bar codes.

For 1:

m	Bar Code Type	Defined region of k	Defined region of d
0	UPC-A	$11 \leq k \leq 12$	$48 \leq d \leq 57$
1	UPC-E	$11 \leq k \leq 12$	$48 \leq d \leq 57$
2	JAN13 (EAN13)	$12 \leq k \leq 13$	$48 \leq d \leq 57$
3	JAN8 (EAN8)	$7 \leq k \leq 8$	$48 \leq d \leq 57$
4	CODE39	$1 \leq k$	$48 \leq d \leq 57, 65 \leq d \leq 90, 32, 36, 37, 43, 45, 46, 47$
5	ITF	$2 \leq k$ (However, this is an even number.)	$48 \leq d \leq 57$
6	CODABAR	$1 \leq k$	$48 \leq d \leq 57, 65 \leq d \leq 68, 36, 43, 45, 46, 47, 58$

For 2:

m	Bar Code Type	Defined region of n	Defined region of d
65	UPC-A	$11 \leq n \leq 12$	$48 \leq d \leq 57$
66	UPC-E	$11 \leq n \leq 12$	$48 \leq d \leq 57$
67	JAN13(EAN13)	$12 \leq n \leq 13$	$48 \leq d \leq 57$
68	JAN8(EAN8)	$7 \leq n \leq 8$	$48 \leq d \leq 57$
69	CODE39	$1 \leq n \leq 255$	$48 \leq d \leq 57, 65 \leq d \leq 90, 32, 36, 37, 43, 45, 46, 47$
70	ITF	$2 \leq n \leq 255$ (Even number)	$48 \leq d \leq 57$
71	CODABAR	$1 \leq n \leq 255$	$48 \leq d \leq 57, 65 \leq d \leq 68, 36, 43, 45, 46, 47, 58$
72	CODE93	$1 \leq n \leq 255$	$0 \leq d \leq 127$
73	CODE128	$2 \leq n \leq 255$	$0 \leq d \leq 127$

For 3:

m	Bar Code Type	Defined region of n	Defined region of d
65	UPC-A	$11 \leq n \leq 12$	$48 \leq d \leq 57$
66	UPC-E	$11 \leq n \leq 12$	$48 \leq d \leq 57$
67	JAN13(EAN13)	$12 \leq n \leq 13$	$48 \leq d \leq 57$
68	JAN8(EAN8)	$7 \leq n \leq 8$	$48 \leq d \leq 57$
69	CODE39	$1 \leq n \leq 255$	$48 \leq d \leq 57, 65 \leq d \leq 90, 32, 36, 37, 43, 45, 46, 47, 42(d1,dk)$
70	ITF	$2 \leq n \leq 255$ (Even number)	$48 \leq d \leq 57$
71	CODABAR	$1 \leq n \leq 255$	$48 \leq d \leq 57, 65 \leq d \leq 68, 36, 43, 45, 46, 47, 58$
72	CODE93	$1 \leq n \leq 255$	$0 \leq d \leq 127$
73	CODE128	$2 \leq n \leq 255$	$0 \leq d \leq 127$
74	GS1-128	$2 \leq n \leq 255$	$0 \leq d \leq 127$
75	GS1 DataBar Omnidirectional	$n=13$	$48 \leq d \leq 57$
76	GS1 DataBar Truncated	$n=13$	$48 \leq d \leq 57$
77	GS1 DataBar Limited	$n=13$	$48 \leq d \leq 57$ [However, $48 \leq d1 \leq 49$ ]
78	GS1 DataBar Expanded	$2 \leq n \leq 255$	$32 \leq d \leq 34, 37 \leq d \leq 63, 65 \leq d \leq 90, d = 95, 97 \leq d \leq 122, d = 123$ [However, $d1 = 40, 48 \leq d2 \leq 57, 48 \leq d3 \leq 57,$ or $48 \leq d1 \leq 57, 48 \leq d2 \leq 57$ ]

Details

For 1:

- This command is quit by the NULL code.
- For UPC-A and UPC-E, a bar code is printed when 12 bytes of bar code data are input. Subsequent data is processed as normal data.
- For JAN13 (EAN13), a bar code is printed when 13 bytes of bar code data are input. Subsequent data is processed as normal data.
- For JAN8 (EAN8), a bar code is printed when 8 bytes of bar code data are input. Subsequent data is processed as normal data.
- The data count for ITF bar codes is always even numbered. If the data count is odd numbered, the last data is ignored.

For 2:

- n specifies the data count. n bytes from the next data is processed as bar code data.
- If n is outside of the defined region, the command is stopped and normal printing commences from subsequent data.
- ITF bar code data count must always be odd. The last data will be ignored for even numbered data.

When in standard mode:

- If d is outside of the defined region, only a paper feed is executed and normal printing commences from subsequent data.
- If the horizontal width of the bar code exceeds the print region of one line, the paper is fed without printing the bar code.
- Executes a paper feed for the height of the bar code (including HRI characters when HRI character printing is specified) regardless of the line feed amount using the following commands.
  - a. ESC 2: Set default line spacing
  - b. ESC 3: Set line feed amount
- This command is effective only when no data exists in the print buffer. If there is data in the print buffer, data after m is printed as normal data.
- Sets the next print position to the beginning of the next line after printing the bar code.
- Print mode (enhanced printing, duplex printing, underlines, character size, 90° rotation) is unaffected, except upside-down printing.

When in page mode:

- Executes only a bar code expansion but does not print it. After expanding the bar code, the next dot after the last data of the bar code is the starting position for the expansion of subsequent data.
- If d is outside of the defined region, the command is stopped and normal printing commences from subsequent data. The position for starting data expansion does not move.
- If the horizontal width of the bar code exceeds the print region of one line, the data expansion starting position is moved to the left side outside the printing region without printing the bar code.

For 3:

- n specifies the data count. n bytes from the next data is processed as bar code data.
- When n exceeds the region, n bytes are received and discarded.
- ITF bar code data count must always be odd. The last data will be ignored for even numbered data.

When in standard mode:

- When d exceeds the region, only paper feed is executed, and data is received for the counter and discarded.
- If the horizontal width of the bar code exceeds the print region of one line, the paper is fed without printing the bar code.



- Executes a paper feed for the height of the bar code (including HRI characters when HRI character printing is specified) regardless of the line feed amount using the following commands.
  - a. ESC 2: Set default line spacing
  - b. ESC 3: Set line feed amount
- This is valid only when there is no data in the print buffer. When there is data in the print buffer, it is received by the counter and then discarded.
- Sets the next print position to the beginning of the next line after printing the bar code.
- Print mode (enhanced printing, duplex printing, underlines, character size, 90° rotation) is unaffected, except upside-down printing.

When in page mode:

- Only the bar code is deployed. Printing is not executed. After deploying the bar code, the next dot of the final bar code data becomes the start position for the next data deployment.
- When d exceeds the region, command processing is stopped, and data is received for the counter and discarded.

The data deployment start position is not moved at this point.

- When the width of the bar code exceeds the print area for one line, the data deployment start position for bar code printing is moved to the left beyond the print area and printing is not executed.

<When using CODE 93 bar code (m = 72)>

- Prints an HRI character (□) of the start characters at the top of the HRI character string.
- Prints an HRI character (□) of the end characters at the top of the HRI character string.
- Prints HRI characters of the control characters (00H to 1FH and 7FH) combining (■) and one letter of the alphabet.

Control Characters			HRI Characters	Control Characters			HRI Characters
ASCII	Hex.	Decimal		ASCII	Hex.	Decimal	
NUL	00	0	■U	DLE	10	16	■P
SOH	01	1	■A	DC1	11	17	■Q
STX	02	2	■B	DC2	12	18	■R
ETX	03	3	■C	DC3	13	19	■S
EOT	04	4	■D	DC4	14	20	■T
ENQ	05	5	■E	NAK	15	21	■U
ACK	06	6	■F	SYN	16	22	■V
BEL	07	7	■G	ETB	17	23	■W
BS	08	8	■H	CAN	18	24	■X
HT	09	9	■I	EM	19	25	■Y
LF	0A	10	■J	SUB	1A	26	■Z
VT	0B	11	■K	ESC	1B	27	■A
FF	0C	12	■L	FS	1C	28	■B
CR	0D	13	■M	GS	1D	29	■C
SO	0E	14	■N	RS	1E	30	■D
SI	0F	15	■O	US	1F	31	■E
				DEL	7F	127	■T

<When using CODE 128 bar code (m = 73)>

- See Appendix-6 for details on CODE 128 bar codes and code tables.
- To print CODE 128 bar codes on this printer, be careful of the following points to send the bar code data.
  - a. At the top of the bar code string, always set the code set selection characters (either of the CODE A, CODE B, or CODE C) to select the initial code set.
  - b. Specify special characters using the two characters of '{' and one subsequent character. Also, the '{' of the ASCII characters are specified by sending '{{' for two characters consecutively.

Special Characters	Transmission Data		
	ASCII	Hex.	Decimal
SHIFT	{S	7B, 53	123, 83
CODE A	{A	7B, 41	123, 65
CODE B	{B	7B, 42	123, 66
CODE C	{C	7B, 43	123, 67
FNC1	{1	7B, 31	123, 49
FNC2	{2	7B, 32	123, 50
FNC3	{3	7B, 33	123, 51
FNC4	{4	7B, 34	123, 52
'{'	{{	7B, 7B	123, 123

- If the top of the bar code data string is not a code set selection character, the command is stopped and processing is handled normally from subsequent data.
- If the combination of '{' and 1 character immediately after does not conform to either of the special characters, the command is stopped and processing is handled normally from subsequent data.
- If a character that cannot be used with the selected code set is received, the command is stopped and processing is handled normally from subsequent data.
- HRI characters that correspond to shift characters and code set selection characters are not printed.
- HRI characters of function characters are printed with a space.
- HRI characters of the control characters (00H to 1FH and 7FH) are printed with a space.

<When using GS1-128 (m = 74)>

- Be sure to note the following points when sending bar code data for GS1-128 bar code printing.

The following four special characters operate as shown below.

Special Characters	Transmission Data		
	Hex.	Decimal	
SP	20	32	The first SP after d1 is the data division identifier for identifying (AI). The SP is reflected by the HRI but is not included in the encoding data.
(	28	40	“(“ is reflected by the HRI. This is useful when using “(,)” to highlight the AI. It is not included in encoding data.
)	29	41	The first “)” after d1 is the data division identifier for identifying (AI). The “)” is reflected by the HRI but is not included in the encoding data.
*	2A	42	The check digit calculated by modulus 10 is inserted automatically at the position specified in “*”. The check digit is reflected in the HRI instead of the “*”.

Also the following characters are expressed as 2 bytes.

Special Characters	Transmission Data		
	ASCII	Hex.	Decimal
FNC1	{1	7B, 31	123, 49
FNC3	{3	7B, 33	123, 51
'(	{(	7B, 28	123, 40
')	{}	7B, 29	123, 41
'*'	{*	7B, 2A	123, 42
'{'	{{	7B, 7B	123, 123
FNC3	{3	7B, 33	123, 51
FNC4	{4	7B, 34	123, 52
'{'	{{	7B, 7B	123, 123

- A space character is used as the HRI character for FNC1 and FNC3 function characters.
- A space character is used as the HRI control characters (00H to 1FH and 7FH).

<When using GS1 Databar Expanded (m = 78)>

To print GS1 Databar Expanded on this printer, be careful of the following points to send the bar code data.

The following special characters operate as shown below.

Special Characters	Transmission Data		
	Hex.	Decimal	
(	28	40	“(“ is reflected by the HRI. This is useful when using “(,)” to highlight the AI. It is not included in encoding data.
)	29	41	The first “)” after d1 is the data division identifier for identifying (AI). The “)” is reflected by the HRI but is not included in the encoding data.

Also the following characters are expressed as 2 bytes.

Special Characters	Transmission Data		
	ASCII	Hex.	Decimal
FNC1	{1	7B, 31	123, 49
'{'	{{	7B, 28	123, 40
'}'	{}	7B, 29	123, 41

- If the double-digit lead for the bar code data line is not a number, or is not “(“ and a number, command

processing is stopped at this point and the next data is processed as standard data.

- If the combination of ‘{‘ and the character directly behind does not correspond to, command processing is

stopped at this point and the next data is processed as standard data.

- Although “\*” can be used, it is not reflected in the HRI or the encoding data.

STAR

- If printing bar codes that require check digits on STAR printers, even if the check digit is sent as a bar code, the check digit that was calculated on the printer is printed.

Reference

GS H, GS f, GS h, GS w, Appendix-6

**GS r n**

Name	Transmission of status			
Code	ASCII	GS	r	n
	Hex.	1D	72	n
	Decimal	29	114	n

Defined Region n = 1, 2, 49, 50

Function Sends the specified status.

- n = 1, 49: Sends paper detector status
- n = 2, 50: Sends the drawer kick connector status.

Details

- When using a serial interface:
- When in DTR/DSR control: Sends the status after checking that the host can received data. If the host is not able to receive data, it waits until reception is possible.
- When in XON/XOFF control: The printer transmits statuses without confirming whether the host computer can receive data.
- Because this command is executed while expanding the reception buffer, there may be a delay between the reception of the command and the status transmission, depending on the reception buffer status.
- When ASB is enabled , the status transmitted by this command and the ASB status must be differentiated. See Appendix-2 for details on how to identify.

Detector Status (n = 1, 49)

Bit	Status	"0"	"1"
7	Fixed at "0"		
6	Undefined	---	---
5	Undefined	---	---
4	Fixed at "0"		
3	Paper roll end detector	Has Paper	Paper out
2	Paper roll end detector	Has Paper	Paper out
1	Paper roll near end detector	Has Paper	Paper out
0	Paper roll near end detector	Has Paper	Paper out

Bit-2,3: If the end detector shows there is no paper, the printer will always go offline, so this command is not executed. Therefore, the status of bit - 2 = 1 or bit - 3 = 1 is not sent.

Drawer Kick Connector Status (n = 2, 50)

Bit	Status	"0"	"1"
7	Fixed at "0"		
6	Undefined	---	---
5	Undefined	---	---
4	Fixed at "0"		
3	Undefined	---	---
2	Undefined	---	---
1	Undefined	---	---
0	Drawer kick connector pin #3	"L"	"H"

Reference DLE EOT, Appendix-2

**GS v 0 m xL xH yL yH d1 ... dk**

Name	Print raster bit images								
Code	ASCII	GS	v	0	m	xL	xH	yL	yH d1...dk
	Hex.	1D	76	30	m	xL	xH	yL	yH d1...dk
	Decimal	29	118	48	m	xL	xH	yL	yH d1...dk

Defined Region  $0 \leq m \leq 3, 48 \leq m \leq 51$   
 $0 \leq xL \leq 128, xH=0 (0 \leq xL + xH \times 256) \leq 128)$   
 $0 \leq yL \leq 255, 0 \leq yH \leq 15 (0 \leq yL + yH \times 256 \leq 4095)$   
 $0 \leq d \leq 255$   
 $k = (xL + xH \times 256) \times (yL + yH \times 256)$  However,  $k \neq 0$

Function Prints raster method bit images using mode m.

m	Mode	Density of Vert. Dir. Dots	Density of Hor. Dir. Dots
0, 48	Normal Mode	180 DPI	180 DPI
1, 49	Double-wide Mode	180 DPI	90 DPI
2, 50	Double-tall Mode	90 DPI	180 DPI
3, 51	Quadruple Mode	90 DPI	90 DPI

- xL and xH specify the horizontal direction data count for one bit image ( $xL + xH \times 256$ ) in bytes.
  - yL and yH specify the vertical direction data count for one bit image ( $yL + yH \times 256$ ) in dots.
- Details
- This command is effective only when there is no print data in the print buffer when standard mode is selected.
  - Print modes (character size, enhanced characters, duplicated characters, upside down, unline, black/white inverted, etc.) do not affect raster bit images.
  - Data not in the print region is discarded in dot increments.
  - It is possible to specify any position to start printing raster bit images according to HT (Horizontal tab), ESC \$ (Specify absolute position), ESC \ (Specify relative position) and GS L (Specify let margin). However, if the print starting position is not a multiple of 8, printing speed will decrease.
  - ESC a (Position alignment) settings are effective also for raster bit images.
  - When executing this command while defining a macro, the macro definition is terminated and the command commences with processing.  
The macro during this time is undefined.
  - d specifies defined data.
  - Bits that correspond to the dots to print are 1, and the bits that correspond to the dots that are not printed are 0.
- STAR
- On STAR printers, the ACK pulse width when using a parallel interface is fixed at 1  $\mu$ sec.
  - When in page mode, transmission of this command is prohibited. If sent, the results of the print are not guaranteed.
  - Dot density (when the STAR printer head = 203 DPI) on STAR printers.

m	Mode	Density of Vert. Dir. Dots	Density of Hor. Dir. Dots
0, 48	Normal Mode	203 DPI	203 DPI
1, 49	Double-wide Mode	203 DPI	101 DPI
2, 50	Double-tall Mode	101 DPI	203 DPI
3, 51	Quadruple Mode	101 DPI	101 DPI

[Ex.:]

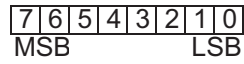
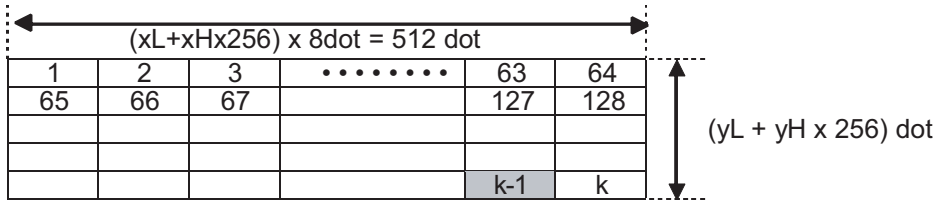
 When  $xL + xH \times 256 = 64$ 

**GS w n**

Name Set bar code horizontal size

Code ASCII GS w n  
 Hex. 1D 77 n  
 Decimal 29 119 n

Defined Region  $1 \leq n \leq 6$

Initial Value  $n = 3$

Function Sets the bar code horizontal size.

n	Multi-level Bar Code Module Width [mm]	Binary Level Bar Code	
		Fine Element Width [mm]	Thick Element Width [mm]
1	0.141	0.141	0.423
2	0.282	0.282	0.706
3	0.423	0.423	1.129
4	0.564	0.564	1.411
5	0.706	0.706	1.834
6	0.847	0.847	2.258

**Details**

- Multi-level bar codes specify the follow bar code types.  
 UPC-A, UPC-E, JAN13 (EAN13), JAN8 (EAN8), CODE 93, CODE 128
- Binary level bar codes specify the follow bar code types.  
 CODE39, ITF, CODABAR

**STAR**

- The bar codes that are printed do not conform to each standard, so you should confirm before actual use.  
 Particularly, if  $n = 1$  is specified, the bar code is not guaranteed.
- The following are the module widths on STAR printers.

n	Multi-level Bar Code Module Width [mm]	Binary Level Bar Code	
		Fine Element Width [mm]	Thick Element Width [mm]
1	0.125	0.125	0.375
2	0.25	0.25	0.625
3	0.375	0.375	1.125
4	0.5	0.5	1.375
5	0.625	0.625	1.75
6	0.75	0.75	2.25

Reference GS k



### 4-3-2 Chinese Character Control Commands

Chinese character control commands are ignored by models shipped to single-byte countries. All Chinese character control commands are ignored if the specification for the location of use is specified as SBCS (single byte countries) by the memory switch.

#### FS ! n

Name Batch specify Chinese character print mode

Code	ASCII	FS	!	n
	Hex.	1C	21	n
	Decimal	28	33	n

Defined Region  $0 \leq n \leq 255$

Initial Value  $n = 0$

Function Batch specifies the Chinese character print mode

Bit	Function	"0"	"1"
7	Underline	OFF	ON
6	Undefined	---	---
5	Undefined	---	---
4	Undefined	---	---
3	Double tall expanded	OFF	ON
2	Expanded wide	OFF	ON
1	Undefined	---	---
0	Undefined	---	---

- Details
- Quadruple-size characters are printed by specifying both double-tall and double-wide modes.
  - An underline is applied to Chinese characters for the entire character width, including the FS S (left and right character space amount).  
However, underlines are not applied to portions that have been skipped using HT (horizontal tab) or rotated 90 degrees.
  - The width of the Chinese character underline is set by FS - (specify Chinese character underline) regardless of the character size.
  - The base line for characters is the same when there are characters having different vertical direction ratios in the same line.
  - Chinese character size can be specified by FS W and GS !, but the last executed command is effective.
  - Chinese character underline is specified and cancelled by FS -, but the last executed command is effective.
- STAR
- This command is ignored when the memory switch location of use is specified as SBCS (single byte countries).
- Reference FS -, FS W, GS !

- Name Specify Kanji mode
- Code ASCII FS &  
Hex. 1C 26  
Decimal 28 38
- Function Specifies Kanji mode.
- Details < Japanese Kanji Specifications >
- Kanji mode specification using this command is enabled only when using JIS codes.
  - If the Kanji mode is specified, all character codes are handled as 2 byte Chinese character codes.
  - Kanji codes are processed in the order first byte, second byte.
  - Kanji mode is cancelled as the default setting.
  - It is possible to select the Kanji code type using FS C.
- < Chinese Kanji Specifications/ Taiwanese Kanji Specifications/ Korean Kanji Specifications>
- If Kanji mode is specified, the first byte that follows processing of the character code equivalent to the first byte of the Kanji code is processed as the second byte of the Kanji code.
  - Kanji codes are processed in the order first byte, second byte.
  - Kanji mode is specified as the default setting.
- STAR
- This command is ignored when the memory switch location of use is specified as SBCS (single byte countries).
  - ANK adornment commands are possible for Kanji enhancement (ESC E) and black/white inversion (GS B) However, if the Kanji is enlarged over three times, enhancement is ignored.
- Specifications A: Enhancement of Kanji is ignored for those characters rotated 90 degrees to the right (ESC V) .
- Specifications B: Enhancement of Kanji is effective for those characters rotated 90 degrees to the right (ESC V).
- The following shows the 2 byte code defined area.

Specifications	Defined Area	
	Upper Bytes	Lower Bytes
Japanese Kanji Characters JIS Type	0x21 to 0x7E	0x21 to 0x7E
Japanese Kanji Characters/Shift JIS Type	0x81 to 0x9F 0xE0 to 0xEF	0x40 to 0xFE
Chinese Kanji characters	0xA1 to 0xFD	0xA1 to FE (*)
Taiwanese Kanji characters	0xA1 to 0xFD	0x40 to FE
Korean Kanji characters	0xA1 to 0xFD	0xA1 to FE

(\*) Bit – 7 of the lower bytes of the Chinese Kanji is always processed as MASK (0xA1A1 → 0xA121)

Reference FS., FS C

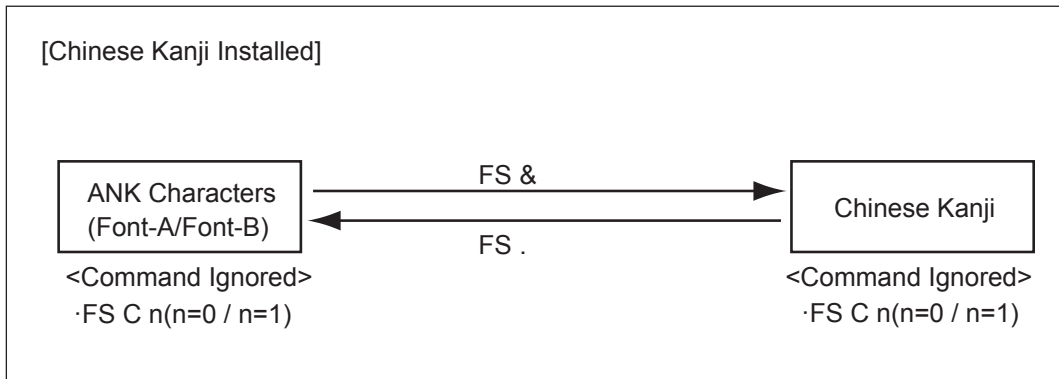
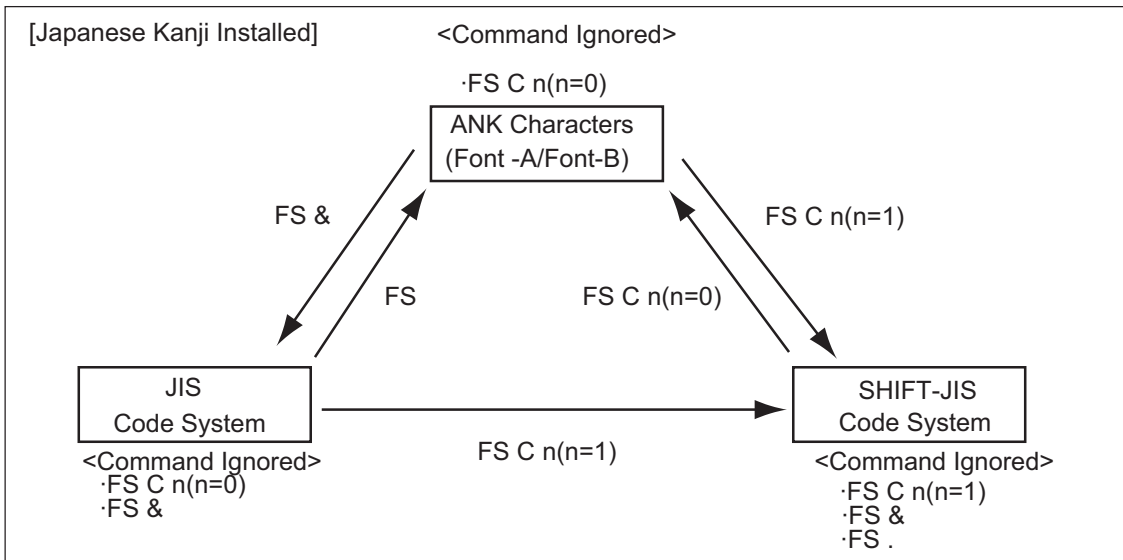

**FS - n**

Name Specify/cancel Chinese character underline

Code ASCII FS - n  
 Hex. 1C 2D n  
 Decimal 28 45 n

Defined Region  $0 \leq n \leq 2, 48 \leq n \leq 50$

Initial Value n = 0

Function Specifies or cancels Chinese character underlines.

n	Function
0, 48	Cancels Chinese character underline
1, 49	Sets to one-dot width Chinese character underline and specifies Chinese character underlines.
2, 50	Sets to two-dot width Chinese character underline and cancels Chinese character underlines.

Details

- An underline is applied to Chinese characters for the entire character width, including the left and right character space amount.

However, underlines are not applied to portions that have been skipped using HT (horizontal tab) or rotated 90 degrees to the right.

- When Chinese character underline mode is cancelled by setting the value of n to 0, subsequent Chinese character data is not underlined, and the underline thickness set before the mode is turned off is maintained.

In default, the underline width for Chinese characters is set to 1 dot.

- The set Chinese character underline width is the constant specified thickness regardless of the size of the character.
- The FS ! (Batch specify Chinese character print mode) command can also turn Chinese character underline mode on or off, but the setting of the last received command is effective.

STAR

- This command is ignored when the memory switch location of use is specified as SBCS (single byte countries).

- The underline for Chinese characters is applied in the following positions.

- 1-dot width underline → 24<sup>th</sup> dot
- 2-dot thickness underline → 23<sup>rd</sup> and 24<sup>th</sup> dot

Reference FS !

**FS .**

Name	Cancel Chinese character mode
Code	ASCII      FS      . Hex.        1C    2E Decimal     28    46
Function	Cancels Chinese characters mode.
Details	<p>&lt; Japanese Language Character Specifications &gt;</p> <ul style="list-style-type: none"> <li>• Chinese characters mode specification using this command is cancelled only when using JIS codes.</li> <li>• If the Chinese character mode is specified, all character codes are handled as 1 byte ASCII codes.</li> <li>• Chinese character mode is cancelled as the default setting.</li> </ul> <p>&lt; Chinese Kanji Specifications/ Taiwanese Kanji Specifications/ Korean Kanji Specifications &gt;</p> <ul style="list-style-type: none"> <li>• If the Chinese character mode is specified, all character codes are handled as 1 byte ASCII codes.</li> <li>• Chinese character mode is specified as the default setting.</li> </ul>
STAR	<ul style="list-style-type: none"> <li>• This command is ignored when the memory switch location of use is specified as SBCS (single byte countries).</li> </ul>
Reference	FS &, FS C

**FS 2 c1 c2 d1 ... dk**

Name	Define external character				
Code	ASCII	FS	2	c1	c2d1...dk
	Hex.	1C	32	c1	c2d1...dk
	Decimal	28	50	c1	c2d1...dk

Defined Region • c1 and c2 differ according to specifications and code type. See below.

Specifications	c1	c2
Japanese Kanji Specifications (JIS code type)	c1=77H	21H ≤ c2 ≤ 7EH
Japanese Kanji Specifications (SHIFT-JIS code type)	c1=ECH	40H ≤ c2 ≤ 7EH 80H ≤ c2 ≤ 9EH
Chinese Kanji Specifications	c1=FEH	A1H ≤ c2 ≤ FEH
Taiwanese Kanji Specifications	c1=FEH	A1H ≤ c2 ≤ FEH
Korean Kanji Specifications	c1=FEH	A1H ≤ c2 ≤ FEH

- $0 \leq d \leq 255$

- $k = 72$

Initial Value	All spaces
Function	Defines the external character pattern of the Chinese character to a character code specified by c1 and c2.
Details	<ul style="list-style-type: none"> <li>• c1 and c2 indicate the Chinese character code that defines the external character; c1 is the first byte; c2 is the second byte.</li> <li>• d specifies defined data. Bits that correspond to the dots to print are 1, and the bits that correspond to the dots that are not printed are 0.</li> <li>• Defined data is cleared by ESC @.</li> </ul>
STAR	<ul style="list-style-type: none"> <li>• This command is ignored when the memory switch location of use is specified as SBCS (single byte countries).</li> <li>• External character registration of JIS codes and SHIFT-JIS codes for Japanese characters uses the same region.</li> </ul>
Reference	FS C

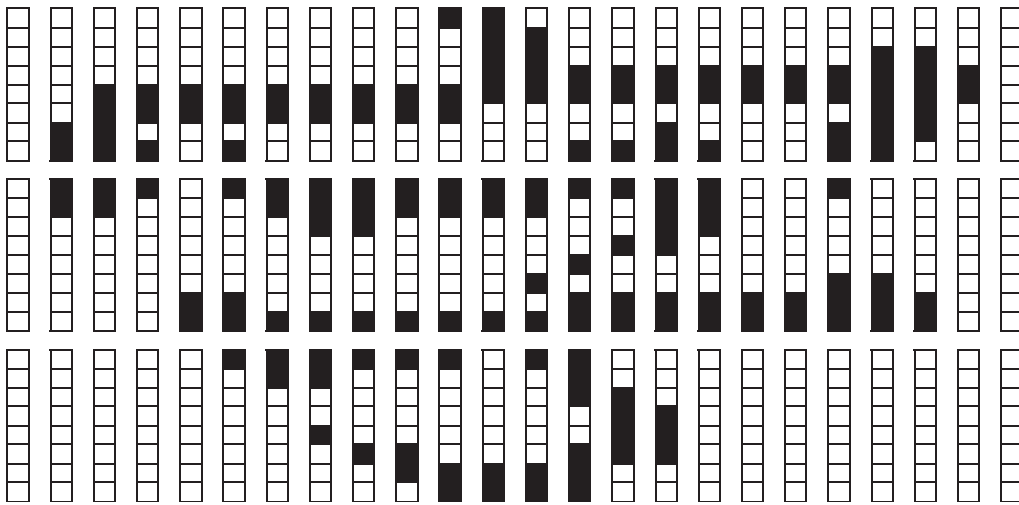
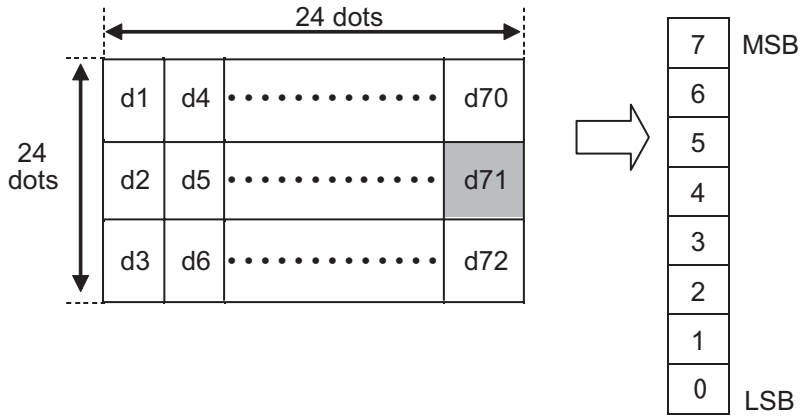

d1 = <00>H    d4 = <03>H    d7 = <0F>H    d10 = <0D>H    d13 = <0C>H    d16 = <0D>H ...  
 d2 = <00>H    d5 = <0C>H    d8 = <0C>H    d11 = <80>H    d14 = <03>H    d17 = <83>H ...  
 d3 = <00>H    d6 = <00>H    d9 = <00>H    d12 = <00>H    d15 = <00>H    d18 = <80>H ...

**FS C n**

Name	Select Chinese character code type			
Code	ASCII	FS	C	n
	Hex.	1C	43	n
	Decimal	28	67	n
Defined Region	n = 0, 1, 48, 49			
Initial Value	n = 0			
Function	Selects the Chinese character code type.			

n	Selection
0, 48	JIS Code Type
1, 49	SHIFT-JIS Code Type

Details	<ul style="list-style-type: none"> <li>If using the JIS code type, the Chinese characters codes below are effective. This command is enabled only when using Japanese language specifications.            First Byte: &lt;21&gt;H to &lt;7E&gt;H            Second Byte: &lt;21&gt;H to &lt;7E&gt;H</li> <li>If using the SHIFT-JIS code type, the Chinese characters codes below are effective.            First Byte: &lt;81&gt;H to &lt;9F&gt;H and &lt;E0&gt;H to &lt;EF&gt;H            Second Byte: &lt;40&gt;H to &lt;7E&gt;H and &lt;80&gt;H to &lt;FC&gt;H</li> </ul>
STAR	<ul style="list-style-type: none"> <li>This command is ignored when the memory switch location of use is specified as SBCS (single byte countries).</li> </ul>



**FS S n1 n2**

Name	Set Chinese character space amount				
Code	ASCII	FS	S	n1	n2
	Hex.	1C	53	n1	n2
	Decimal	28	83	n1	n2
Defined Region	$0 \leq n1 \leq 255$				
	$0 \leq n2 \leq 255$				
Initial Value	n1 = 0, n2 = 0				
Function	Sets the Chinese character left and right space amounts. <ul style="list-style-type: none"> <li>• Left space amount: n1 x (basic calculated pitch)</li> <li>• Right space amount: n2 x (basic calculated pitch)</li> </ul>				
Details	<ul style="list-style-type: none"> <li>• The space amount set by this command is the amount when using standard sized characters.             <p>When expanding characters more than double in the horizontal direction, the space amount is [set amount x horizontal direction magnification].</p> </li> <li>• Space amount can be set independently for both the standard and page modes.</li> <li>• The basic calculated pitch is set by GSP (Set basic calculated pitch). Also, after setting the Chinese character space amount, it is not affected even if the basic calculated pitch is changed.</li> <li>• If there are fractions in the result, correct to the minimum mechanical pitch and discard.</li> <li>• Use the basic calculated pitch (x) for the horizontal direction in standard mode.</li> <li>• The Kanji character width is (“left space amount” + “Kanji font dot count” + “right space amount”) x (basic calculated pitch).             <p>(See the information on character specifications in the appropriate printer specifications manual for details on the Kanji font dot count.)</p> </li> <li>• In page mode, the basic calculated pitch that is used according to the starting point is shown below.             <ol style="list-style-type: none"> <li>a. When the starting point is specified to be upper left or lower right by the ESC T command (Character print direction selection in page mode), the basic calculated pitch (x) for the horizontal direction is used.</li> <li>b. When the starting point is specified to be upper right or lower left by the ESC T command, the basic calculated pitch (y) for the vertical direction is used.</li> <li>c. The maximum value for the left or right space for Chinese characters is approximately 35.893 mm (255/180 inches). Specifications that exceed the maximum value are rounded off to that value.</li> </ol> </li> </ul>				
STAR	<ul style="list-style-type: none"> <li>• This command is ignored when the memory switch location of use is specified as SBCS (single byte countries).</li> </ul>				
Reference	GS P				

**FS W n**

Name	Specify/cancel double-tall, double wide Chinese characters			
Code	ASCII	FS	W	n
	Hex.	1C	57	n
	Decimal	28	87	n
Defined Region	$0 \leq n \leq 255$			
Initial Value	n = 0			
Function	Specifies or cancels quadruple size Chinese characters. <ul style="list-style-type: none"> <li>• Cancels quadruple size when n = &lt;*****0&gt;B.</li> <li>• Specifies quadruple size when n = &lt;*****1&gt;B.</li> </ul>			
Details	<ul style="list-style-type: none"> <li>• n is effective only when it is the lowest bit.</li> <li>• Quadruple size characters are those characters that have both vertical and horizontal directions expanded simultaneously.</li> <li>• If quadruple size is cancelled using this command, the next Chinese character data is printed at normal size.</li> <li>• The base line for characters is the same when there are characters having different vertical direction ratios in the same line.</li> <li>• The FS ! (Batch specify Chinese character print mode) command or GS ! (Specify character size) can also specify the Chinese character size, but the setting of the last received command is effective.</li> </ul>			
STAR	<ul style="list-style-type: none"> <li>• This command is ignored when the memory switch location of use is specified as SBCS (single byte countries).</li> </ul>			
Reference	FS !, GS !			

### 4-3-3 ESC/POS Black Mark Commands

ESC/POS black mark related commands are to control the top of form (black mark) functions. These commands are effective only when the black mark function is valid.

#### <Black mark specifications>

##### 1. Top of form (black mark detection) operation

- A. Selectable when power is turned on (when a reset signal is input), when a self-print test is completed, when the cover is closed and by the memory switch.
- B. When the Feed switch is pressed  
Performs Top of Form (black mark detection) operation
- C. Command  
See the following command details.

##### 2 Black Mark Errors

- A. Black mark error is entered
  - When white detection is detected continuously over 400mm when feeding paper – A black mark error occurs
  - When black detection is detected continuously over 9mm when feeding paper – A paper out error occurs  
(On models that dually use paper out sensor for the black mark sensor, the error is a paper out error.)
- B. Operations during a black mark error
  - Error LED flashes
  - Feed switch is invalid
  - Only the following commands are invalid. Other commands are ignored.  
DLE EOT n: Real-time Status Command  
DLE ENQ n: Real-time Request Command (Black Mark Error Cancel Command)
  - ASB Status is valid.
- C. How to cancel a black mark error
  - Turn power on again (reset signal is input)
  - Real-time request command (Black mark error cancel command) DLE ENQ n cancel the error.

<b><u>FF</u></b>	
Name	Print and recover to page mode
Code	ASCII      FF
	Hex.        0C
	Decimal     12
Function	<ul style="list-style-type: none"> <li>• When in page mode, this prints all buffered data to the print region collectively, then recovers to the standard mode.</li> <li>• In standard mode, this prints the data in the print buffer and feeds paper to the TOF position (the black mark).</li> </ul>
Details	<ul style="list-style-type: none"> <li>• In page mode, all buffer data is deleted after printing.</li> <li>• In page mode, the print area set by ESCW (Set print region in page mode) is reset to the default setting.</li> <li>• In page mode, no paper cut is executed.</li> <li>• In page mode, this sets the print position to the beginning of the next line after execution.</li> </ul>
STAR	<ul style="list-style-type: none"> <li>• The TOF position (black mark) varies according to the paper used and to customer specifications.</li> </ul>
Reference	ESC FF, ESC L, ESC S

**DLE ENQ n**

Name	Real-time request to printer									
Code	<table border="0"> <tr> <td>ASCII</td> <td>DLE ENQ</td> <td>n</td> </tr> <tr> <td>Hex.</td> <td>10 05</td> <td>n</td> </tr> <tr> <td>Decimal</td> <td>16 5</td> <td>n</td> </tr> </table>	ASCII	DLE ENQ	n	Hex.	10 05	n	Decimal	16 5	n
ASCII	DLE ENQ	n								
Hex.	10 05	n								
Decimal	16 5	n								
Defined Region	$1 \leq n \leq 2$									
Function	<p>Responds to requests n specifications from the host in real-time. n specifications are below.</p> <p>n = 1: Recover from the error and start printing from the line where the error occurred.</p> <p>n = 2: Recover from error after clearing the reception buffer and print buffer.</p>									
Details	<ul style="list-style-type: none"> <li>• This command is enabled even when the printer specification is disabled by ESC = (select peripheral devices).</li> <li>• This command is enabled only when an auto-cutter and black mark errors occur.</li> <li>• This command is processed upon reception.</li> <li>• This command is executed even when the printer is offline, the reception buffer is full, or there is an error status on serial interface models.</li> <li>• This command cannot be executed when the printer is BUSY on parallel interface models. The printer will not enter a BUSY status when offline or when there is an error when BUSY condition of reception buffer full, offline/reception buffer full is handled as a reception buffer full.</li> <li>• The printer retains the settings by ESC !, ESC 3, that were in effect when an error occurred even when DLE ENQ 2 is executed. The printer is initialized completely using this command and ESC @.</li> </ul>									
Notes:	<ul style="list-style-type: none"> <li>• Operators must use caution for other commands when the data string of &lt;10&gt;H&lt;05&gt;H&lt;n&gt; (<math>1 \leq n \leq 2</math>) is received because it operates in the same manner as this command.</li> </ul>									
Ex.:	<p>In ESC * m nL nH [d]k, d1 = &lt;10&gt;H, d2 = &lt;05&gt;H, d3 = &lt;01&gt;H</p> <ul style="list-style-type: none"> <li>• Do not use this command to interrupt code strings of other commands that consist of 2 or more codes.</li> </ul>									
Ex.:	<p>If you attempt to transmit DLE EBQ 2 up to transmitting ESC3 by trying to transmit ESC 3 n from the host, it is processed as ESC 3 10H. Operators must use caution.</p>									
STAR	<ul style="list-style-type: none"> <li>• Auto-cutter error specifications vary according to model, so for models for which there are non-recoverable auto-cutter errors, three bytes of this command are ignored. See Appendix-2 for details on auto-cutter error specifications for model types.</li> <li>• The black mark error is canceled and the printer feeds paper to the top of form position (black mark position) when this command is received during a black mark error. Paper is cut according to the memory switch setting (paper position, cover close setting).</li> <li>• Models connected to a presenter ignore this command.</li> <li>• When this command is set to n = 2, the printer is reset.</li> </ul>									
Reference	DLE EOT, Appendix-2									

**GS FF**

Name	Top of form of mark paper
Code	ASCII      GS    FF
	Hex.        1D   0C
	Decimal    29   12
Function	Top of form of mark paper
Details	<ul style="list-style-type: none"> <li>• This command is effective only when BM is valid. This command is ignored when BM is invalid.</li> <li>• This command is enabled only when at the top of the line.</li> <li>• This command moves to the TOF position of BM.</li> </ul>
STAR	<ul style="list-style-type: none"> <li>• STAR printers ignore this command.</li> <li>• Byte counts specified by (pL + pH x 256) are discarded.</li> </ul>
Reference	GS ( F, FF

**GS ( F pL pH a m nL nH**

Name	Set black mark adjustment value
Code	ASCII GS ( F pL pH a m nL nH Hex. 1D 28 46 pL pH 61 m nL nH Decimal 29 40 70 pL pH 97 m nL nH
Defined Region	$(pL+pH \times 256) = 4, pL = 4, pH = 0$ $1 \leq a \leq 2$ $m = 0, 1, 48, 49$ $0 \leq nL + nH \times 256 \leq 65535, 0 \leq nL \leq 255, 0 \leq nH \leq 255$
Initial Value	All adjustment values = 0
Function	Sets the adjustment value of the black mark detection position. a specifies the type of adjustment value.

a	Function
1	Sets the adjustment value of the black mark detection position.
2	Sets the adjustment value of the paper cutting position after black mark detection.

m specifies the direction of adjustment.

m	Function
0, 48	Forward Direction (Paper Feed Direction)
1, 49	Reverse Direction

nL, nH specify the amount of adjustment.

Details	<ul style="list-style-type: none"> <li>• When processing this command while defining a macro, the macro definition is immediately terminated and the command commences with processing.</li> <li>• The black mark detection position (a = 1) is affected by the following command operations.           <ul style="list-style-type: none"> <li>• FF</li> <li>• GS FF</li> </ul> </li> <li>• The paper cutting position after black mark detection (a = 2) is affected by the following command operation.           <ul style="list-style-type: none"> <li>• GS V m n</li> </ul> </li> <li>• Because this command is executed when processing a normal command after it is stored once in the reception buffer, there may be a delay between the reception of the command from the reception buffer to the actual operation.</li> </ul>
STAR	<ul style="list-style-type: none"> <li>• On STAR printers, the default value of the black mark detection position is 2 mm from the bottom edge of the mark so, to make it the same position as on EPSON printers, it is necessary to adjust the position using this command.</li> </ul>
Reference	FF, GS FF, GS V

**GS ( M pL pH n m (Function Code: n = 1, 49)**

Name Save black mark adjustment value

Code	ASCII	GS	(	M	pL	pH	n	m
	Hex.	1D	28	4D	pL	pH	n	m
	Decimal	29	40	77	pL	pH	n	m

Defined Region (pL+pHx256) = 2, pL = 2, pH = 0  
 n = 1, 49  
 $1 \leq m \leq 3, 49 \leq m \leq 51$

Function • Saves the black mark adjustment value set by the GS (F command to the mth region in the volatile memory.

After saving to a non-volatile memory, the printer is reset.

m	Function
1	Saves the adjustment value to the 1 <sup>st</sup> saving region of the non-volatile memory.
2	Saves the adjustment value to the 2 <sup>nd</sup> saving region of the non-volatile memory.
3	Saves the adjustment value to the 3 <sup>rd</sup> saving region of the non-volatile memory.

Consider the life of the non-volatile memory and avoid over-use of this command.

Reference GS ( F



**GS ( M pL pH n m (Function Code: n = 2, 50)**

Name                    Load black mark adjustment value

Code	ASCII	GS	(	M	pL	pH	n	m
	Hex.	1D	28	4D	pL	pH	n	m
	Decimal	29	40	77	pL	pH	n	m

Defined Region    (pL+pHx256) = 2, pL = 2, pH = 0  
                           n = 2, 50  
                            $1 \leq m \leq 3, 49 \leq m \leq 51$

Function                Loads the m position black mark adjustment value in the volatile memory.

m	Function
1	Loads the adjustment value from the 1 <sup>st</sup> saving region of the non-volatile memory.
2	Loads the adjustment value from the 2 <sup>nd</sup> saving region of the non-volatile memory.
3	Loads the adjustment value from the 3 <sup>rd</sup> saving region of the non-volatile memory.

Reference              GS ( F

**GS ( M pL pH n m (Function Code: n = 3, 51)**

Name Set black mark adjustment value auto-load when powering on

Code ASCII GS ( M pL pH n m  
 Hex. 1D 28 4D pL pH n m  
 Decimal 29 40 77 pL pH n m

Defined Region (pL+pHx256) = 2, pL = 2, pH = 0  
 n = 3, 51  
 $1 \leq m \leq 3, 49 \leq m \leq 51$

Function Validates/invalidates the black mark adjustment value auto-load when powering on.  
 After saving the setting to the non-volatile memory, the printer is reset.

m	Function
0	Auto-load function invalid
1	Auto-loads the 1 <sup>st</sup> adjustment value of the non-volatile memory when powering on.
2	Auto-loads the 2 <sup>nd</sup> adjustment value of the non-volatile memory when powering on.
3	Auto-loads the 3 <sup>rd</sup> adjustment value of the non-volatile memory when powering on.

Consider the life of the non-volatile memory and avoid over-use of this command.

Reference GS ( F

**GS <**

Name	Mechanically initialize printer		
Code	ASCII	GS	<
	Hex.	1D	3C
	Decimal	29	60
Function	Cuts paper after feeding to the TOF (black mark).		
Details	<ul style="list-style-type: none"><li>• Does not affect other settings.</li><li>• This command is effective in standard mode and page mode.</li></ul>		
STAR	<ul style="list-style-type: none"><li>• The TOF position (black mark) varies according to the paper used and to customer specifications.</li></ul>		

**GS V m n**

Name	Cut paper				
Code	ASCII	GS	V	m	n
	Hex.	1D	56	m	n
	Decimal	29	86	m	n
Defined Region	m = 65, 66, $0 \leq n \leq 255$				
Function	Executes the specified paper cut.				

m	Function
65	Feeds paper to (cutting position + [n x basic calculated pitch]) and performs a full cut
66	Feeds paper to (cutting position + [n x basic calculated pitch]) and performs a partial cut (one point uncut)
67	Not Used
68	Not Used

Details	<ul style="list-style-type: none"> <li>• This command is effective only when processed at the top of the line when standard mode is being used.</li> <li>• Feeds paper to the TOF position (black mark) when <math>n = 0</math>, then cuts the paper.</li> <li>• Feeds paper [n x basic calculated pitch] beyond the TOF position (black mark) when <math>n \neq 0</math>, then cuts the paper.</li> <li>• The basic calculated pitch is set by GSP (Set basic calculated pitch).</li> <li>• Use the basic calculated pitch (y) relating to the vertical direction for the paper feed amount. If the calculation results in fractions, the pitch is corrected to a minimal mechanical pitch and the rest is discarded.</li> </ul>
STAR	<ul style="list-style-type: none"> <li>• The auto-cut function differs according to the model. A partial cut is executed on those models that cannot perform a full cut. A full cut is executed on those models that cannot perform a partial cut. Refer to the product specifications manual for the specifications of the auto-cut function.</li> <li>• Models that do not have the auto-cut function do not cut paper. However, commands that accompany a paper feed of (cutting position + [n x basic calculated pitch]) (<math>n = 65, 66</math>), a paper feed of (tear bar position + [n x basic calculated pitch]) is executed.</li> <li>• The TOF position (black mark) varies according to the paper used and to customer specifications.</li> </ul>
Reference	ESC i, ESC m

#### 4-3-4 STAR Original Commands

STAR original commands are not regulated by the ESC/POS control codes, but are standard for improved functions and for independent STAR functions.

##### ESC GS = nL nH da1 ... dak db1 ...dbk

Name	Write data to a blank code page						
Code	ASCII	ESC	GS	=	nL	nHda1...dak	db1...dbk
	Hex.	1B	1D	3D	nL	nHda1...dak	db1...dbk
	Decimal	27	29	61	nL	nHda1...dak	db1...dbk
Defined Region	nL = 0 nH = 48 $1 \leq nL + (nH \times 256)$ $0 \leq da \leq 255$ (Font-A Data) $0 \leq db \leq 255$ (Font-B Data) $k = nL + (nH \times 256) \div 2$						
Function	<ul style="list-style-type: none"> <li>• Stores blank code page data in non-volatile memory.</li> </ul>						
Details	<ul style="list-style-type: none"> <li>• A blank code page is a character code table that is completely free of character codes 80H to FFH. It is selected when the character code table selection command (ESC tn) sets n = 255, or (ESC GS t n) sets n = 255.</li> <li>• The following are data that is written to the blank code page.            Font-A: 1 Character = 48 bytes; 6144 bytes = 48 bytes x 128 characters            Font-B: 1 Character = 48 bytes; 6144 bytes = 48 bytes x 128 characters</li> <li>• Font-A data and Font-B data is sent continuously.</li> <li>• The printer is reset after writing with to the non-volatile memory.</li> </ul>						
Reference	ESC t, ESC GS t, Appendix-3						

**ESC GS t n**

Name	Select character code table				
Code	ASCII	ESC	GS	t	n
	Hex.	1B	1D	74	n
	Decimal	27	29	116	n

Function Selects character code table.

Specifications A:

Setting Value of n		Character Table
Hex.	Decimal	
00	0	Normal*
01	1	CodePage437 (USA, Std. Europe)
02	2	Katakana
03	3	CodePage437 (USA, Std. Europe)
04	4	Codepage 858 (Multilingual)
05	5	Codepage 852 (Latin-2)
06	6	Codepage 860 (Portuguese)
07	7	Codepage 861 (Icelandic)
08	8	Codepage 863 (Canadian French)
09	9	Codepage 865 (Nordic)
0A	10	Codepage 866 (Cyrillic Russian)
0B	11	Codepage 855 (Cyrillic Bulgarian)
0C	12	Codepage 857 (Turkish)
0D	13	Codepage 862 (Hebrew)
0E	14	Codepage 864 (Arabic)
0F	15	Codepage 737 (Greek)
10	16	Codepage 851 (Greek)
11	17	Codepage 869 (Greek)
12	18	Codepage 928 (Greek)
13	19	Codepage 772 (Lithuanian)
14	20	Codepage 774 (Lithuanian)
15	21	Codepage 874 (Thai)
-----		
20	32	Codepage 1252 (Windows Latin-1)
21	33	Codepage 1250 (Windows Latin-2)
22	34	Codepage 1251 (Windows Cyrillic)
-----		
40	64	Codepage 3840 (IBM-Russian)
41	65	Codepage 3841 (Gost)
42	66	Codepage 3843 (Polish)
43	67	Codepage 3844 (CS2)
44	68	Codepage 3845 (Hungarian)
45	69	Codepage 3846 (Turkish)
46	70	Codepage 3847 (Brazil-ABNT)
47	71	Codepage 3848 (Brazil-ABICOMP)
48	72	Codepage 1001 (Arabic)
49	73	Codepage 2001 (Lithuanian-KBL)
4A	74	Codepage 3001 (Estonian-1)
4B	75	Codepage 3002 (Estonian-2)
4C	76	Codepage 3011 (Latvian-1)
4D	77	Codepage 3012 (Latvian-2)
4E	78	Codepage 3021 (Bulgarian)
4F	79	Codepage 3041 (Maltese)
-----		
FF	255	Blank page

## Specifications B:

Setting Value of n		Character Table
Hex.	Decimal	
00	0	Normal*
01	1	CodePage437 (USA, Std. Europe)
02	2	Katakana
03	3	CodePage437 (USA, Std. Europe)
04	4	Codepage 858 (Multilingual)
05	5	Codepage 852 (Latin-2)
06	6	Codepage 860 (Portuguese)
07	7	Codepage 861 (Icelandic)
08	8	Codepage 863 (Canadian French)
09	9	Codepage 865 (Nordic)
0A	10	Codepage 866 (Cyrillic Russian)
0B	11	Codepage 855 (Cyrillic Bulgarian)
0C	12	Codepage 857 (Turkish)
0D	13	Codepage 862 (Hebrew)
0E	14	Codepage 864 (Arabic)
0F	15	Codepage 737 (Greek)
10	16	Codepage 851 (Greek)
11	17	Codepage 869 (Greek)
12	18	Codepage 928 (Greek)
13	19	Codepage 772 (Lithuanian)
14	20	Codepage 774 (Lithuanian)
15	21	Codepage 874 (Thai)
-----		
20	32	Codepage 1252 (Windows Latin-1)
21	33	Codepage 1250 (Windows Latin-2)
22	34	Codepage 1251 (Windows Cyrillic)
-----		
40	64	Codepage 3840 (IBM-Russian)
41	65	Codepage 3841 (Gost)
42	66	Codepage 3843 (Polish)
43	67	Codepage 3844 (CS2)
44	68	Codepage 3845 (Hungarian)
45	69	Codepage 3846 (Turkish)
46	70	Codepage 3847 (Brazil-ABNT)
47	71	Codepage 3848 (Brazil-ABICOMP)
48	72	Codepage 1001 (Arabic)
49	73	Codepage 2001 (Lithuanian-KBL)
4A	74	Codepage 3001 (Estonian-1)
4B	75	Codepage 3002 (Estonian-2)
4C	76	Codepage 3011 (Latvian-1)
4D	77	Codepage 3012 (Latvian-2)
4E	78	Codepage 3021 (Bulgarian)
4F	79	Codepage 3041 (Maltese)
-----		
60	96	Thai Character Code 42 (Thai)
61	97	Thai Character Code 11 (Thai)
62	98	Thai Character Code 13 (Thai)
63	99	Thai Character Code 14 (Thai)
64	100	Thai Character Code 16 (Thai)
65	101	Thai Character Code 17 (Thai)
66	102	Thai Character Code 18 (Thai)
-----		
FF	255	Blank page

## Details

- Command ignored when n other than definition is input.

**ESC GS # m N n1 n2 n3 n4 LF NUL**

Name Memory Switch Settings

Code	ASCII	ESC	GS	#	m	N	n1	n2	n3	n4	LF	NUL
	Hex.	1B	1D	23	m	N	n1	n2	n3	n4	0A	00
	Decimal	27	29	35	m	N	n1	n2	n3	n4	10	0

Defined Region  $48 \leq n1 \leq 57$  ("0"  $\leq$  n1  $\leq$  "9"),  $65 \leq n1 \leq 70$  ("A"  $\leq$  n1  $\leq$  "F"),  $97 \leq n1 \leq 102$  ("a"  $\leq$  n1  $\leq$  "f")  
 $48 \leq n2 \leq 57$  ("0"  $\leq$  n2  $\leq$  "9"),  $65 \leq n2 \leq 70$  ("A"  $\leq$  n2  $\leq$  "F"),  $97 \leq n2 \leq 102$  ("a"  $\leq$  n1  $\leq$  "f")  
 $48 \leq n3 \leq 57$  ("0"  $\leq$  n3  $\leq$  "9"),  $65 \leq n3 \leq 70$  ("A"  $\leq$  n3  $\leq$  "F"),  $97 \leq n3 \leq 102$  ("a"  $\leq$  n3  $\leq$  "f")  
 $48 \leq n4 \leq 57$  ("0"  $\leq$  n4  $\leq$  "9"),  $65 \leq n4 \leq 70$  ("A"  $\leq$  n4  $\leq$  "F"),  $97 \leq n4 \leq 102$  ("a"  $\leq$  n4  $\leq$  "f")

Spec. A

 $m = 87, 84, 44, 43, 45, 64$  ( $m =$  "W", "T", ",", "+", "-", "@")

 $48 \leq N \leq 57$  ("0"  $\leq$  N  $\leq$  "9"),  $65 \leq N \leq (*)70$  ("A"  $\leq$  N  $\leq$  (\*)"F"),  $97 \leq N \leq (*) 102$ , ("a"  $\leq$  N  $\leq$  (\*) (\*) "f")

Spec. B

 $m = 87, 84, 44, 43, 45, 64$  ( $m =$  "W", "T", ",", "+", "-", "@")

 $48 \leq N \leq 57$  ("0"  $\leq$  N  $\leq$  "9"),  $65 \leq N \leq (*)70$  ("A"  $\leq$  N  $\leq$  (\*)"F"),  $97 \leq N \leq (*) 102$ , ("a"  $\leq$  N  $\leq$  (\*) (\*) "f")

 $N = 85$  (N = "U") User defined area

Spec. C

 $m = 87, 84, 44, 43, 45, 64, 42$  ( $m =$  "W", "T", ",", "+", "-", "@", "\*\*")

 $48 \leq N \leq 57$  ("0"  $\leq$  N  $\leq$  "9"),  $65 \leq N \leq (*)70$  ("A"  $\leq$  N  $\leq$  (\*)"F"),  $97 \leq N \leq (*) 102$ , ("a"  $\leq$  N  $\leq$  (\*) (\*) "f")

 $N = 85$  (N = "U") User defined area

(\*) The memory switch defined area differs according to the model.

Initial Value ---

Function Sends command to write after defining memory switch using the definition command specified by the following classes.

Memory switch information defined by the command to write is written to the volatile memory.

When writing to the volatile memory by the command to write, the printer executes a reset.

This command exists in models that have the specifications of A, B, and C as indicated in the above defined areas.

Models having B and C specifications can register any 16 bit data by specifying N = 85 (U).

Models with Spec. C can load the factory default settings by specifying m=42 (\*\*).

(See the "Special Appendix, Command Table per Model" for details per model.)

Consider the life of the non-volatile memory and avoid over-use of this command.

Function	Class	m	N	n1 n2 n3 n4
Definition data write and reset	Write	"W"	Fixed at "0"	Fixed at "0000"
Definition data write and reset and test print	Write	"T"	Fixed at "0"	Fixed at "0000"
Data Definition (Data Specification)	Definition	","	N	n1 n2 n3 n4
Data definition (Set specified bit)	Definition	"+"	N	n1 n2 n3 n4
Data definition (Clear specified bit)	Definition	"-"	N	n1 n2 n3 n4
Data Definition (Initialize all data)	Definition	"@"	Fixed at "0"	Fixed at "0000"
Data Definition (Load Factory Default Setting)	Defiition	"**"	Fixed at "0"	Fixed at "0000"



- m: Mode Selection
- N: Memory switch number to specify
- n1 n2 n3 n4: Specified Data
  - m = “,” → Specified Data
  - m = “+” → Bit number to set
  - m = “-” → Bit number that was cleared.

**ESC RS F n**

Name	Select Font				
Code	ASCII	ESC	RS	F	n
	Hex.	1B	1E	46	n
	Decimal	27	30	70	n
Defined Region	$0 \leq n \leq 1, n = 16$				
Initial Value	n = 0				
Function	• Selects the font.				

n	Font
0	Font A (12 x 24 dots)
1	Font B (9 x 24 dots)
16	OCR B (16 x 24 dots)

The functions outlined below are disabled when the OCR B font is selected.

- Code page
- Blank code page
- Country characters
- Slashed zero

Character modifier, expansion and external character settings are disabled when using the OCR B font for reading using a scanner. Check the OCR B font in actual use before using.

**ESC RS C n**

Name	Print Mode Selection				
Code	ASCII	ESC	RS	C	n
	Hex.	1B	1E	43	n
	Decimal	27	30	67	n
Defined Region	$0 \leq n \leq 1$		$48 \leq n \leq 49$		
	n=16,n=32				
Initial Value	---				
Function	Selects print mode				

n	Print Mode
0,48	Single color mode
1,49	2-color mode
16	Low power consumption mode
32	Double resolution mode

- This command is ignored when low power consumption mode is selected.
- This command is not cleared by ESC @.
- If there is unprinted data in the line buffer, the printing of the line buffer data will be executed.
- This command is processed after the current printing has been completed.
- This command is ignored when reduced printing in the vertical direction is setting.

**ESC RS L m**

Name Batch Control Logo

Code ASCII ESC RS L m  
 Hex. 1B 1E 4C m  
 Decimal 27 30 76 m

Defined Region Spec. A  $m = 255$   
 Spec. B  $0 \leq m \leq 3$ ,  $48 \leq m \leq 51$  ("0"  $\leq m \leq$  "3"),  $m = 255$ )

Initial Value ---

Function Spec. A: Batch deletes all registered logos.  
 After printing is completed, the printer is reset.

Spec. B: Performs a control specified by parameter m for the logo.  
 After execution, the printer is reset

m	Logo Control Mode
0, 48	Normal mode, batch printing
1, 49	Double-wide mode, batch printing
2, 50	Double-tall mode, batch printing
3, 51	Double-wide, double tall mode, batch printing
255	Batch delete logos

This command is ignored in page mode.

**ESC GS ETX s n1 n2**

Name Send print-end counter, initialize

Code ASCII ESC GS ETX s n1 n2  
 Hex. 1B 1D 03 s n1 n2  
 Decimal 27 29 3 s n1 n2

Defined Region Spec. A:  $0 \leq s \leq 2$   
 Spec. B:  $0 \leq s \leq 4$   
 Spec. C:  $0 \leq s \leq 5$   
 $0 \leq n1 \leq 255, 0 \leq n2 \leq 255$

Function This command is run when reading from the reception buffer. Processes the print end counter according to the s parameter.

s	Name	Function
0	Print end counter reference	Sends the current print end counter to the host. (Does not wait for print end. Does not count up.)
1	Print end counter update	Runs the next operation. (1) Prints data in line buffer, if data exists. (2) Waits until printing ends (motor stops). (3) Updates print end counter (+1) (4) Sends print end counter to host.
2	Print end counter clear	Returns the print end counter to its default value (zero clear). (Does not wait for print end. Does not send the print end counter to the host.)
3	Start document n1, n2 = 0	(1) Sets data intake mode (2) Initialize
4	End document n1, n2 = 0	(1) Prints data in line buffer, if data exists. (2) Waits until printing ends (motor stops). (3) Cancels data intake mode
5	Data timeout setting	n1=0 : Initializes to the content of MSW. (n2=0) n1=1 : Data timeout setting n2=0: Timeout disabled Others: n2 = Data timeout time (units: seconds 1 to 255 seconds) n1=2 : Sends the current timeout setting to the host. (n2=0)

When s = 0, or s = 1 is specified, the data format returned to the host is as shown below.

<Returned Data Formats>

Code	ASCII	ESC	GS	ETX	s	n1	n2	[Print end counter]	NUL
	Hex.	1B	1D	03	s	n1	n2	[Print end counter]	00
	Decimal	27	29	3	s	n1	n2	[Print end counter]	0

\* Echoes back the specified contents from the host as is until ESC GS ETX s n1 n2, and then sends the print end counter value and NUL.

When [Print end counter] is 1 byte in length, the initial value is 0x00.

When s = 1, increments by 1 each time the command is processed. After 0xFF, returns to 0x00.

There is one [Print end counter] in the printer that is unrelated to the n1, n2 values.

(There is no counter for the n1, n2 values.)

## (Reference Information) Differences between the ETB command and this command

Item	ESC GS ETX s n1 n2	ETB
Affect on ASB (ETB Status)	No	○
ASB Occurrence	No	○
Affect on ASB valid/invalid setting	No	○
Affect of the ESC RS E n command	No	○
Status transmission destination in Ethernet (When multi-sessions is valid)	Send only when in the print session (host) that is connected	Send ASB to all sessions (hosts) that are connected

\* This print end counter and the ETB counter sent by the ETB command are separate. They have no affect on each other.

## (Cautions on Ethernet interfacing)

When using the Ethernet interface, be sure to use the same communication socket for transmission of this command by the host device and for reception of print end counter data (between #9100 port connection and disconnection). After the command has been transmitted, if the socket is disconnected before the print end counter data is received (#9100 port is disconnected), the print end counter data is returned to the next connected socket (#9100 port).

The following shows a communication example of this command.

## Communication Example 1

Host Transmission Data	Printer return data
ESC GS ETX 0x00 0x00 0x00	→
	← ESC GS ETX 0x00 0x00 0x00 0x00 0x00 (Reference Counter)
Print Data + ESC GS ETX 0x01 0x00 0x00	→
	← ESC GS ETX 0x01 0x00 0x00 0x01 0x00 (Reference Update)
Print Data + ESC GS ETX 0x01 0x00 0x00	→
	← ESC GS ETX 0x01 0x00 0x00 0x02 0x00 (Reference Update)

## Communication Example 2

Host Transmission Data	Printer return data
ESC GS ETX 0x02 0x02 0x00	
ESC GS ETX 0x00 0x02 0x00	→ (Clear Counter)
	← ESC GS ETX 0x00 0x02 0x00 0x00 0x00 (Reference Counter)
Print Data + ESC GS ETX 0x01 0x02 0x11	→
	← ESC GS ETX 0x01 0x02 0x11 0x01 0x00 (Reference Update)
Print Data + ESC GS ETX 0x01 0x02 0x12	→
	← ESC GS ETX 0x01 0x02 0x12 0x02 0x00 (Reference Update)
Print Data + ESC GS ETX 0x01 0x02 0x13	→
	← ESC GS ETX 0x01 0x02 0x13 0x03 0x00 (Reference Update)
Print Data + ESC GS ETX 0x01 0x02 0x14	→
	← ESC GS ETX 0x01 0x02 0x14 0x04 0x00 (Reference Update)

## &lt;Example using n1, n2&gt;

- For Ethernet: Specify as n1 = host ID, n2 = document number, and check the compatibility of source information and returned information for the host ID and document ID along with getting the returned print end counter.
- For cases other than Ethernet: Specify n1+n2 x 256 as the document ID and check the compatibility with the document ID in the same way.
- When it is not possible to check compatibility of the source and returned data, fix at n1 = 0, n2 = 0.

When s=3, s=4 (Document start command + document end command) , operates as though in data cancel mode.

If there is an error after receiving the document start command, reception data is received and discarded until the document end command is received when the printer is recovered from the error. If the document end command cannot be recognized, all reception data is destroyed. Timeouts are 10 seconds. Automatically cancels the data intake mode.

#### Restrictions

- 1) Sleep mode decrease
- 2) Invalid when in Page mode
- 3) Disabled in Page mode.

When s = 3, initialize the following settings using the initializing process.

- Set slash zero
- Set specify/cancel external character (external register character data is retained)
- Page length
- Current position (move to top of page, top of line)
- Horizontal tab/Vertical tab
- Set upside-down, position alignment
- Left/right margins

<T: TOP Command/E: END Command>

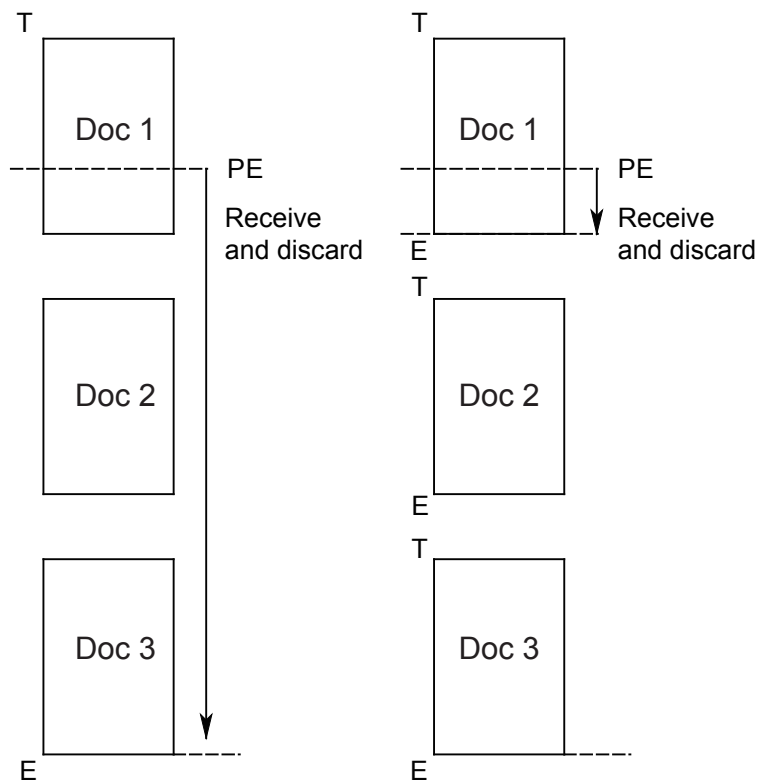

The interface disconnection detection function through data reception timeout is controlled when s=5 is specified.

When this function is enabled, the interface is determined to have been disconnected when no data is received for a specified period of time at the data read section of the printer.

When a disconnection is detected during a command execution, the command parsing is stopped.

When data cancel is enabled, the print start function using the timer (ESC GS g 1) is disabled, and data is canceled.

n1=0 and n2=0: Initializes the interface disconnection detection function through data reception timeout.

(Returns to the MSW settings. The initial value for the timeout time is 3 seconds.)

n1=1 : Set enable/disable and the timeout time for data reception timeouts.

When n2 is 0, the disconnection detection function is disabled due to data reception timeouts.

When n2 is anything except for 0, the data reception timeout is set. (Units: seconds, 1 to 255 seconds)

n1=2 and n2=0: Sends the current setting to the host.

The data format returned to the host is as shown below.

<Returned Data Formats>

Code	ASCII	ESC	GS	ETX	s	n1	n2	[timeout setting]	NUL
	Hex.	1B	1D	03	s	n1	n2	[timeout setting]	00
	Decimal	27	29	3	s	n1	n2	[timeout setting]	0

\* Echoes back the specified contents from the host as is until ESC GS ETX s n1 n2, and then sends the timeout setting value and NUL.



### 4-3-5 STAR Original Presenter Control Commands

The following commands control the presenter functions.

The following commands are effective only on models equipped with a presenter.

#### ESC SYN 0 n

Name Execute presenter paper recovery

Code	ASCII	ESC	SYN	0	n
	Hex.	1B	16	30	n
	Decimal	27	22	48	n

Defined Region n = 0, 48

Function Executes presenter paper recovery.

This command is ignored when a presenter is not connected.

Also, this command is executed when paper is supplied by the presenter, exists in the presenter and the paper has been cut. This command is ignored under all other conditions. (Ignored when paper is being recovered.)

Reference ESC SYN 1, ESC SYN 2, ESC SYN 3, ESC SYN 4

**ESC SYN 1 n**

Name	Set presenter paper recovery function and automatic recovery time
Code	ASCII    ESC SYN    1    n Hex.      1B    16    31    n Decimal    27    22    49    n
Defined Region	$0 \leq n \leq 255$
Initial Value	Memory Switch Setting
Function	Sets presenter paper automatic recovery function and automatic recovery time. This command is ignored when a presenter is not connected. Settings using this command are effective from the next sheet when the printer processes this command and paper has already been supplied to the presenter.

n	Function
n = 0	Paper automatic recovery function invalid.
$1 \leq n \leq 255$	Paper automatic recovery function valid. Automatic recovery time: $n \times 0.5$ sec (0.5 sec to 127.5 sec)

Reference      ESC SYN 0, ESC SYN 2, ESC SYN 3, ESC SYN 4

**ESC SYN 3 n**

Name Get presenter paper counter

Code	ASCII	ESC	SYN	3	n
	Hex.	1B	16	33	n
	Decimal	27	22	51	n

Defined Region n = 0, 1, 48, 49

Function Acquires presenter paper counter.

This command is ignored when a presenter is not connected.

Counter can count to 0xFFFFFFFF sheets.

Counter is cleared to zero when the following conditions are met.

- At a printer reset
- At <ESC> <SYN> 4 n command

The paper counter sends the counter value at the time this command is processed.

The counter is counted up when paper is completely recovered or when pulled out.

The counter counts from when the power is turned ON, excluding the following.

- When paper is discharged because of an error
- When printing using self-print
- When paper in the presenter is discharged when the power is turned ON

n	Counter
n = 0, 48	Acquires paper reel counter
n = 1, 49	Acquires paper recovery counter

<Counter transmission format from printer: When using the paper reel counter>

Printer Transmission: ESC SYN 3 n c1 c2 c3 c4

Reel counter:  $c4 + (c3 \times 256) + (c2 \times 256 \times 256) + (c1 \times 256 \times 256 \times 256)$

Reference ESC SYN 0, ESC SYN 1, ESC SYN 2, ESC SYN 4

**ESC SYN 4 n**

Name	Initialize presenter paper counter				
Code	ASCII	ESC	SYN	4	n
	Hex.	1B	16	34	n
	Decimal	27	22	52	n
Defined Region	n = 0				
Function	Initializes the presenter paper counter (paper reel counter/paper recovery counter). Initialization of the paper counter using this command is executed when this command is processed.				
Reference	ESC SYN 0, ESC SYN 1, ESC SYN 2, ESC SYN 3				

**ESC GS SUB DC1 m t1 t2**

Name Specify snout operation mode  
 Code ASCII ESC GS SUB DC1 m t1 t2  
 Hex. 1B 1D 1A 11 m t1 t2  
 Decimal 27 29 26 17 m t1 t2

Defined Region  $0 \leq m \leq 3$  ( $48 \leq m \leq 51$ )  
 t1 = 0, t2 = 0

Initial Value MSW Setting

Function Specify the snout operation mode using the m parameter.

m	Snout Operating Mode
0, 48	Snout LED output OFF
1, 49	Snout LED output ON (while printing, or during presenter operation)
2, 50	Snout LED output ON (during an error)
3, 51	Snout LED output ON (while printing, or during presenter operation or an error)

This command is valid when a presenter is connected.  
 When the snout is not connected, this command is prohibited from use.

Reference ESC GS SUB DC2, ESC GS SUB DC3

**ESC GS SUB DC2 m t1 t2**

Name Specify Snout LED ON/OFF time  
 Code ASCII ESC GS SUB DC2 m t1 t2  
 Hex. 1B 1D 1A 12 m t1 t2  
 Decimal 27 29 26 18 m t1 t2

Defined Region  $1 \leq m \leq 2, 49 \leq m \leq 50$   
 $0 \leq t1 \leq 255, 0 \leq t2 \leq 255$

Initial Value  $t1 = 2, t2 = 2$

Function Specify Snout LED ON/OFF times.  
 m specifies the snout operation mode.

m	Snout Operating Mode
1, 49	This command specifies the LED ON/OFF times while the presenter is operating. (LED lights in orange while the printer is printing.)
2, 50	This command specifies the LED ON/OFF times for recoverable and non-recoverable errors.

t1 specifies the snout LED ON time.  
 When  $1 \leq t1 \leq 255$ : ON time =  $t1 \times 50$  msec  
 When  $t1 = 0$ : When ON time is default value ( $t1=2$ )  
 t2 specifies the snout LED OFF time.  
 When  $1 \leq t2 \leq 255$ : OFF time =  $t2 \times 50$  msec  
 When  $t2 = 0$ : When OFF time is default value ( $t2=2$ )  
 This command is valid when a presenter is connected.  
 When the snout is not connected, this command is prohibited from use.

Reference ESC GS SUB DC1, ESC GS SUB DC3

**ESC GS SUB DC3 m t1 t2**

Name           Execute snout LED operation  
 Code            ASCII            ESC GS SUB DC2 m t1 t2  
                   Hex.            1B 1D 1A 13 m t1 t2  
                   Decimal        27 29 26 19 m t1 t2

Defined Region        $1 \leq m \leq 2, 49 \leq m \leq 50$   
                            $0 \leq t1 \leq 255, 0 \leq t2 \leq 255$

Initial Value           ---

Function            Operate the snout LED.  
                           m specifies the snout LED output terminal.

m	LED output terminal
1, 49	External output terminal 1
2, 50	External output terminal 2

t1 specifies the ON time for the snout LED operation.

When  $1 \leq t1 \leq 255$ : ON time =  $t1 \times 50$  msec

When  $t1 = 0$  When ON time is default value (Default =  $2 \times 50$  msec)

t2 specifies the OFF time for the snout LED operation.

When  $1 \leq t2 \leq 255$ : OFF time =  $t2 \times 50$  msec

When  $t2 = 0$ : When OFF time is default value (Default =  $2 \times 50$  msec)

This command is valid when a presenter is connected.

When the snout is not connected, this command is prohibited from use.

This command has priority if received while operating the snout LED in the operation mode specified by the

Reference       ESC GS SUB DC2, ESC GS SUB DC3

### 4-3-6 STAR Original Mark Commands

This command is specialized for printing mark sheets for lotteries. This command can print lines.

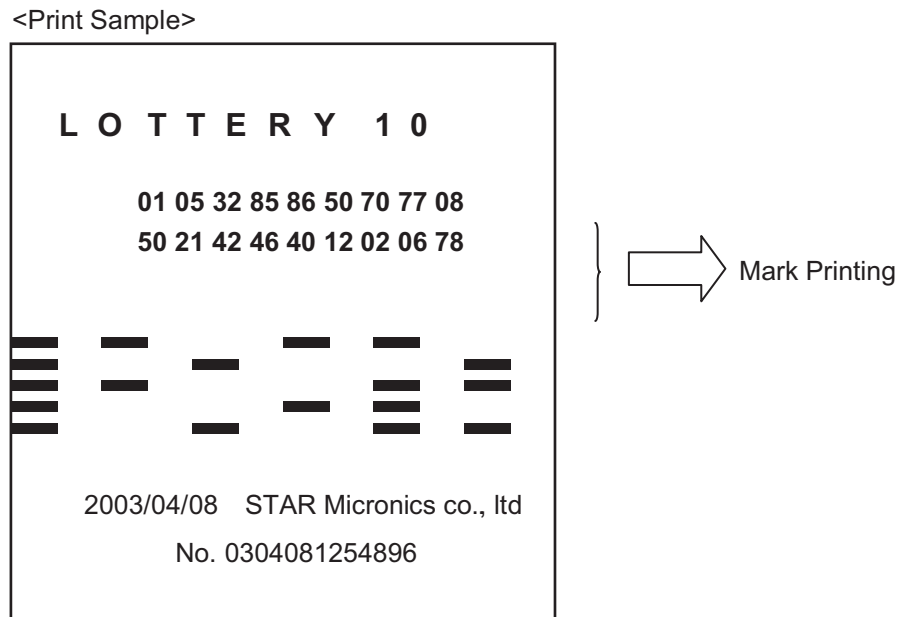

#### <Example of Command Transmission>

##### • Mark Format

Mark Height  $h = 10$  dots, Mark line feed amount  $v = 20$  dots

Mark number 0: Mark Color  $c = \text{White}$ , Mark horizontal width  $w = 16$  dots

Mark number 1: Mark Color  $c = \text{Black}$ , Mark horizontal width  $w = 40$  dots

Mark number 2: Mark Color  $c = \text{White}$ , Mark horizontal width  $w = 40$  dots

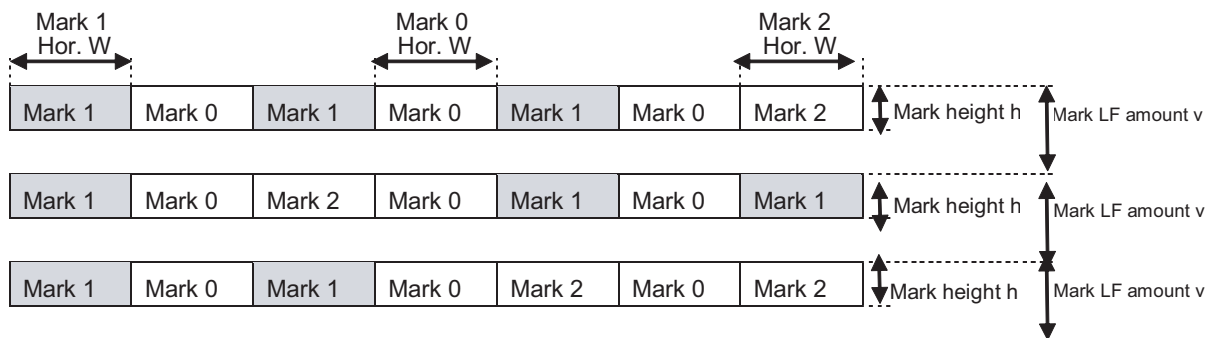

##### • Example Transmission

###### 1. Mark height, Line feed amount setting

<ESC> <GS> \*1 h v ( $h = \text{"010"}$ ,  $v = \text{"020"}$ )

###### 2. Color of each mark number, Horizontal width setting

<ESC> <GS> \*2 m c w (Mark number 0 setting:  $m = \text{"0"}$ ,  $c = \text{"0"}$ ,  $w = \text{"016"}$ )

<ESC> <GS> \*2 m c w (Mark number 1 setting:  $m = \text{"1"}$ ,  $c = \text{"1"}$ ,  $w = \text{"040"}$ )

<ESC> <GS> \*2 m c w (Mark number 2 setting:  $m = \text{"2"}$ ,  $c = \text{"0"}$ ,  $w = \text{"040"}$ )

###### 3. Register the mark format specified by 1 and 2 in advance in the non-volatile memory (it is possible to print marks that are not registered in the non-volatile memory.)

<ESC> <GS> \*W

###### 4. Printing Marks

<ESC><GS>\*0nm1m2m3m4m5m6m7

( $n = \text{"007"}$ ,  $m1 = \text{"1"}$ ,  $m2 = \text{"0"}$ ,  $m3 = \text{"1"}$ ,  $m4 = \text{"0"}$ ,  $m5 = \text{"1"}$ ,  $m6 = \text{"0"}$ ,  $m7 = \text{"2"}$ )

<ESC><GS>\*0nm1m2m3m4m5m6m7

( $n = \text{"007"}$ ,  $m1 = \text{"1"}$ ,  $m2 = \text{"0"}$ ,  $m3 = \text{"2"}$ ,  $m4 = \text{"0"}$ ,  $m5 = \text{"1"}$ ,  $m6 = \text{"0"}$ ,  $m7 = \text{"1"}$ )

<ESC><GS>\*0nm1m2m3m4m5m6m7

( $n = \text{"007"}$ ,  $m1 = \text{"1"}$ ,  $m2 = \text{"0"}$ ,  $m3 = \text{"1"}$ ,  $m4 = \text{"0"}$ ,  $m5 = \text{"2"}$ ,  $m6 = \text{"0"}$ ,  $m7 = \text{"2"}$ )



**ESC GS \* 0 n m1 m2 m3 ... mk**

Name	Print mark
Code	ASCII    ESC    GS    *    0    n    m1    m2    m3    ...    mk
	Hex.        1B    1D    2A    30    n    m1    m2    m3    ...    mk
	Decimal    27    29    42    48    n    m1    m2    m3    ...    mk
Defined Region	"001" ≤ n ≤ "255"
	"0" ≤ m ≤ "9"
	k = n
Initial Value	---
Function	Prints the mark number specified by m, based on the mark format (mark height, mark line feed amount, each mark color, and each mark horizontal width) that is preset.
	n indicates the number of marks to print; If the number of marks is 10 (m1 to m10), n = "010."
	m specifies the mark number to print.
	n and m are ASCII character strings that are represented by decimals; They are composed of character codes "0" to "9."
	This command is ignored if there is print data in the image buffer. Therefore, other characters cannot be included (characters, bit images, bar codes, etc.).
Reference	If there is no mark specified in the remaining print region, the number of bytes specified by n are discarded.
	Also, in page mode, if the value of n is out of the defined range, subsequent data are processed as normal data.
	This command is affected by position alignment, left margin, moved position, positions such as horizontal tab and upside down printing.
Reference	ESC GS * 1, ESC GS * 2, ESC GS * W, ESC GS * C

**ESC GS \* 1 h v**

Name	Specify mark height and line feed																					
Code	<table border="0"> <tr> <td>ASCII</td> <td>ESC</td> <td>GS</td> <td>*</td> <td>1</td> <td>h</td> <td>v</td> </tr> <tr> <td>Hex</td> <td>1B</td> <td>1D</td> <td>2A</td> <td>31</td> <td>h</td> <td>v</td> </tr> <tr> <td>Decimal</td> <td>27</td> <td>29</td> <td>42</td> <td>49</td> <td>h</td> <td>v</td> </tr> </table>	ASCII	ESC	GS	*	1	h	v	Hex	1B	1D	2A	31	h	v	Decimal	27	29	42	49	h	v
ASCII	ESC	GS	*	1	h	v																
Hex	1B	1D	2A	31	h	v																
Decimal	27	29	42	49	h	v																
Defined Region	<p>"001" ≤ h ≤ "255"</p> <p>"001" ≤ v ≤ "255"</p> <p>h ≤ v</p>																					
Initial Value	Non-volatile memory																					
Function	<p>Specifies mark height and line feed amount</p> <p>h is the mark height (number of dots); v is the line feed amount for the mark (number of dots)</p> <p>h and v are ASCII character strings that are represented by decimals; They are composed of character codes "0" to "9."</p> <p>If a small line feed amount is specified, missing print can occur, so more than v = 16 dots is recommended.</p>																					
Reference	ESC GS * 0, ESC GS * 2, ESC GS * W, ESC GS * C																					

**ESC GS \* 2 m c w**

Name	Specify mark color and mark horizontal width for each mark number
Code	ASCII    ESC    GS    *    2    m    c    w Hex.        1B   1D   2A   32   m    c    w Decimal    27   29   42   50   m    c    w
Defined Region	"0" ≤ m ≤ "9" "0" ≤ c ≤ "1" "001" ≤ w ≤ "999"
Initial Value	Non-volatile memory
Function	Specifies mark color and mark horizontal width for each mark number. m specifies the mark number. c specifies the mark color. w specifies the mark horizontal width (number of dots). If w exceeds the print region, this command is ignored. m, c and w are ASCII character strings that are represented by decimals; They are composed of character codes "0" to "9."

c	Mark Color
n = "0" (48)	White
n = "1" (49)	Black

Reference        ESC GS \* 0, ESC GS \* 1, ESC GS \* W, ESC GS \* C

### ESC GS \* W

Name	Register mark format to non-volatile memory															
Code	<table border="0"> <tr> <td>ASCII</td> <td>ESC</td> <td>GS</td> <td>*</td> <td>W</td> </tr> <tr> <td>Hex.</td> <td>1B</td> <td>1D</td> <td>2A</td> <td>57</td> </tr> <tr> <td>Decimal</td> <td>27</td> <td>29</td> <td>42</td> <td>87</td> </tr> </table>	ASCII	ESC	GS	*	W	Hex.	1B	1D	2A	57	Decimal	27	29	42	87
ASCII	ESC	GS	*	W												
Hex.	1B	1D	2A	57												
Decimal	27	29	42	87												
Defined Region	---															
Initial Value	---															
Function	<p>Registers the mark format (mark height, mark line feed amount, each mark color, and each mark horizontal width) to the non-volatile memory.</p> <p>After registering to the non-volatile memory, the printer is reset.</p> <p>Considering the non-volatile memory service life, avoid using this command frequently.</p>															
Reference	ESC GS * 0, ESC GS * 1, ESC GS * 2, ESC GS * C															

### ESC GS \* C

Name	Initialize mark format in the non-volatile memory															
Code	<table border="0"> <tr> <td>ASCII</td> <td>ESC</td> <td>GS</td> <td>*</td> <td>C</td> </tr> <tr> <td>Hex.</td> <td>1B</td> <td>1D</td> <td>2A</td> <td>43</td> </tr> <tr> <td>Decimal</td> <td>27</td> <td>29</td> <td>42</td> <td>67</td> </tr> </table>	ASCII	ESC	GS	*	C	Hex.	1B	1D	2A	43	Decimal	27	29	42	67
ASCII	ESC	GS	*	C												
Hex.	1B	1D	2A	43												
Decimal	27	29	42	67												
Defined Region	---															
Initial Value	---															
Function	<p>Initializes the registered mark format (mark height, mark line feed amount, each mark color, and each mark horizontal width) in the non-volatile memory. After initialization, the printer is reset.</p> <p>Considering the non-volatile memory service life, avoid using this command frequently.</p> <p>Initial Value of the Mark Format</p> <ul style="list-style-type: none"> <li>• Mark Height: "016" (16 dots)</li> <li>• Mark line feed amount: "032" (32 dots)</li> <li>• Mark Color: "0" (White → All mark numbers)</li> <li>• Mark Horizontal Width: "080" (80 dots → All mark numbers)</li> </ul>															
Reference	ESC GS * 0, ESC GS * 1, ESC GS * 2, ESC GS * W															

### 4-3-7 STAR Original Auto Logo Commands

This command functions to print logos, like the one below, by only changing the product name, when only product names can be changed in systems that are already in use. Also, this function has two operating modes.

#### 1) Standard Auto Logo Function

The Auto Logo function is preset and executes the following operations using the print cut command under the current system as a trigger.

1. Starts up the Auto Logo function using the current system cut command as a trigger
2. Prints if there is print data in the image buffer
3. Executes user macro 1
4. Prints Auto Logo
5. Executes user macro 2

Logo 2 is printed by #4 Auto Logo printing according to the command character “/” that was preset in the current print data and embedding the Logo number “2” to print. Specifically, if the product is registered with “CHEESEBURGER/2” the logo 2 coupon ticket is automatically printed for the purchaser of a cheese burger. Also, Logo 1 for the header is used for company logos. By registering to the user macro 2 of #5, cut command + Logo 1 print command, the company logo of logo1 will be printed. User macro 1 of #3 is used when it is necessary to position the Auto Logo in the center. When doing so, register the left alignment command using the user macro 2 of #5 and return to its original setting.

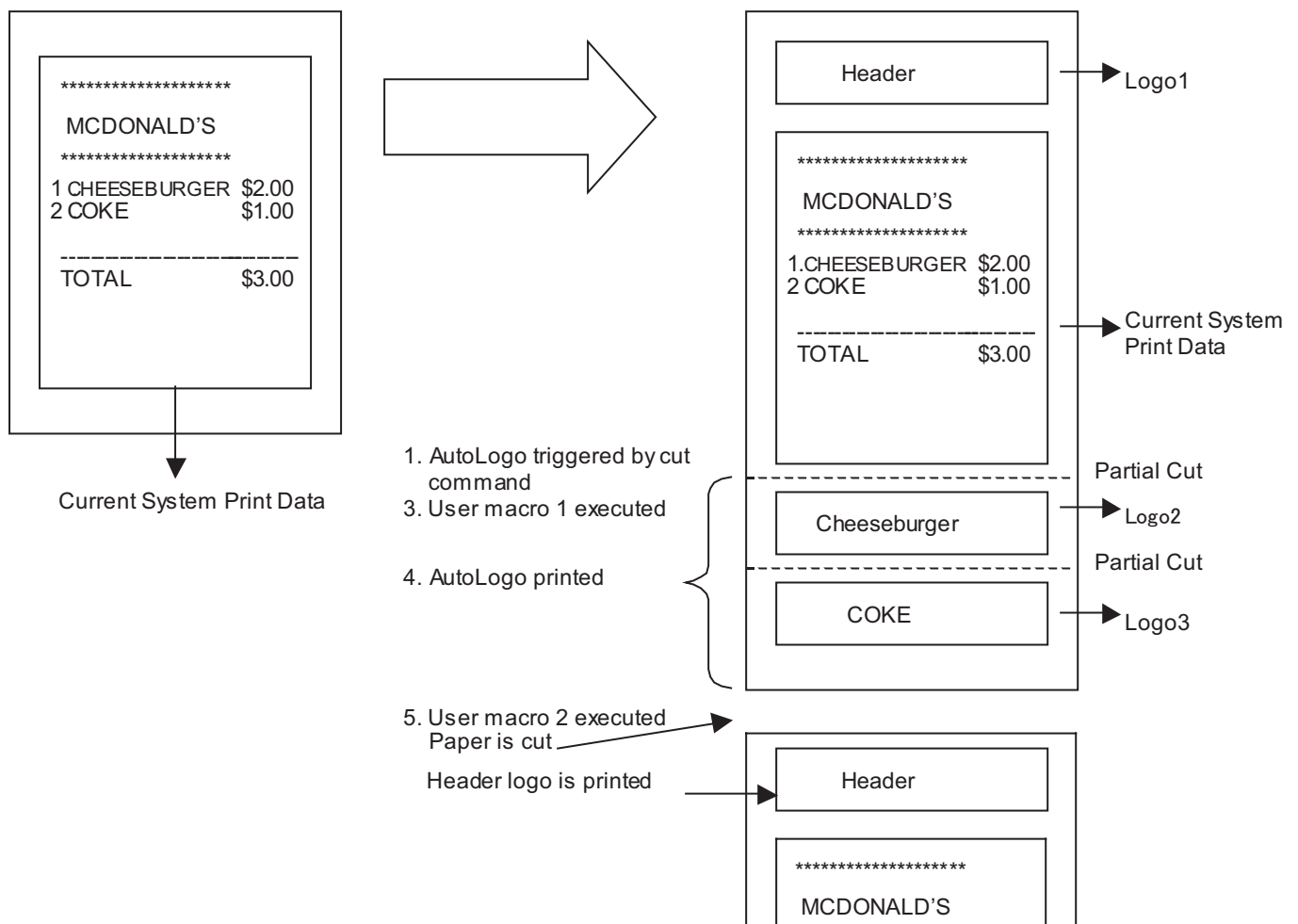

## 2) Simple Auto Logo Functions

The simple Auto Logo function is preset and executes the following operations using the print cut command under the current system as a trigger.

1. Starts up the simple Auto Logo function using the current system cut command as a trigger
2. Center alignment command process
3. Print Logo 2
4. Feed paper to cutting position and executes a partial cut
5. Print Logo 1
6. Recovers position alignment command to setting prior to execution of the simple Auto Logo

With the simple Auto Logo function, the logo number of the logo to be printed is decided in advance.

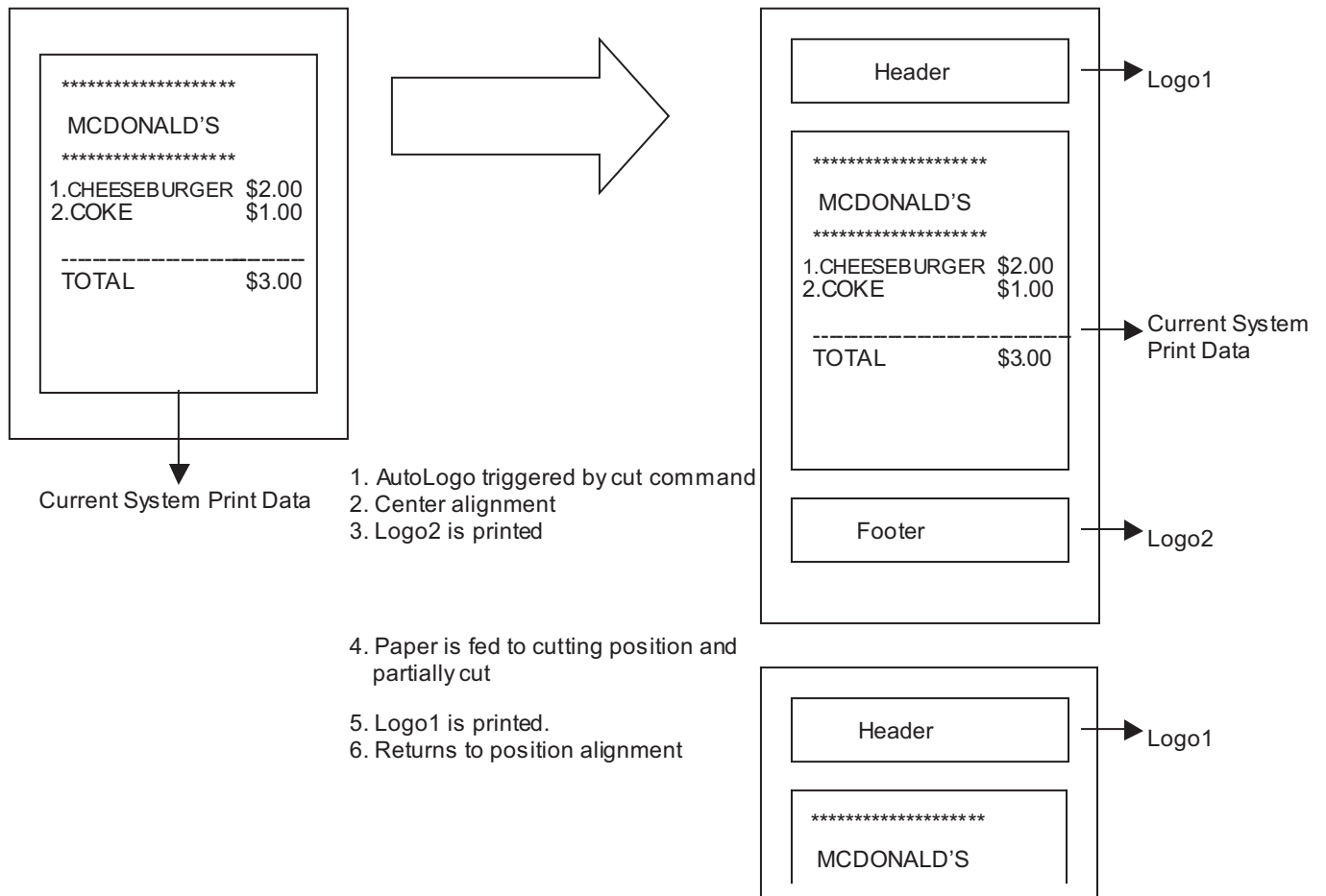

### <Example of Command Transmission>

1) Set the Auto Logo function in advance and register it to the non-volatile memory.

ESCGS/1n (n = 0x01):	Standard Auto Logo Function ON
ESCGS/2n (n = "/>):	Specify Auto Logo Command Character ("/")
ESCGS/3nLnHd1d2...dk:	User Macro 1 Definition
nL = 3n H = 0:	Registered Macro Count = 3 Bytes
d1 = 0x1 bd2 = 0x61 d3 = 0x01:	Registered Macro <ESC a1: Center Alignment>
ESCGS/4nLnHd1d2...dk:	User Macro 2 Definition
nL = 16 nH = 0:	Registered Macro Count = 16 Bytes
d1 = 0x1d d2 = 0x56 d3 = 0x42 d4 = 0x00:	Registered Macro <GS V 660: Transport to Cutting Position and Perform Partial Cut>
d5 = 0x1c d6 = 0x70 d7 = 0x01 d8 = 0x00:	<FS p10: Logo1 Print>
d9 = 0x1b d10 = 0x61 d11 = 0x00:	<ESC a0: Left Alignment>
d12 = 0x1b d13 = 0x70 d14 = 0x03 d15 = 0x64 d16 = 0x00:	<ESC p3 100 0: Draw Drive>
ESCGS/5n (n = 0x01):	Auto Logo Command Character, Space Switch
ESCGS/6n (n = 0x01):	Partial Cut Before Auto Logo Printing Valid
ESCGS/W:	Register Auto Logo Definition Data to Non-volatile Memory

### 2) Send registered command character embedded in print data

"CHEESEBURGER/2" -> "/" is recognized as the Auto Logo command character; "/2" switch to space; "2" specifies Logo2.

**ESC GS / W**

Name	Register Auto Logo setting to non-volatile memory				
Code	ASCII	ESC	GS	/	W
	Hex.	1b	1d	2f	57
	Decimal	27	29	47	87
Defined Region	---				
Initial Value	---				
Function	<p>Registers Auto Logo setting to non-volatile memory</p> <p>After registration, the printer is reset.</p> <p>This command is ignored when Auto Logo is being executed.</p> <p>Considering the non-volatile memory service life, avoid using this command frequently.</p>				
Reference	ESC GS / C, ESC GS / 1, ESC GS / 2, ESC GS / 3, ESC GS / 4, ESC GS / 5, ESCGS/6				



**ESC GS / C**

Name	Initialize Auto Logo setting to non-volatile memory				
Code	ASCII	ESC	GS	/	C
	Hex.	1b	1d	2f	43
	Decimal	27	29	47	67
Defined Region	---				
Initial Value	---				
Function	<p>Initializes registered data in the non-volatile memory of the Auto Logo function.</p> <p>After initialization, the printer is reset.</p> <p>This command is ignored when Auto Logo is being executed.</p> <p>Considering the non-volatile memory service life, avoid using this command frequently.</p>				

The default values of the Auto Logo function are below.

Setting	Initial Value
Auto Logo Function	OFF
Command Character	None
User Macro 1	None
User Macro 2	None
Command Character Switch	No print
Partial Cut Before Auto Logo Printing	Invalid

Reference      ESC GS / W, ESC GS / 1, ESC GS / 2, ESC GS / 3, ESC GS / 4, ESC GS / 5, ESC GS / 6

**ESC GS / 1 n**

Name	Auto Logo Function On/Off Setting
Code	ASCII    ESC    GS    /    1    n Hex.        1b   1d   2f   31   n Decimal    27   29   47   49   n
Defined Region	$0 \leq n \leq 2$
Initial Value	$n = 0$
Function	Turns the Auto Logo function on and off. This command is registered to the non-volatile memory by the "<ESC> <GS> / W" command. When in page mode, the Auto Logo function is invalid. This command is ignored when Auto Logo is being executed.

n	Setting
0	Auto Logo Function Off
1	Standard Auto Logo Function ON <Operation Specifications> 1. Starts up the Auto Logo function using the current system cut command as a trigger 2. Prints if there is print data in the image buffer 3. Executes user macro 1 4. Prints Auto Logo 5. Executes user macro 2
2	Simple Auto Logo Function ON <Operation Specifications> 1. Starts up the Auto Logo function using the current system cut command as a trigger 2. Prints if there is print data in the image buffer 3. Execute center alignment 4. Print Logo 2 (When 2 color printing is set: Logo3) 5. Feed paper to cutting position and execute a partial cut 6. Print Logo 1 7. Recover position alignment setting  Note: • With this setting, user macro and command character are invalid. ("/" is printed as a character if the command character is set to "/" when setting.)

The commands that are the triggers for the Auto Logo function are below.

When the standard Auto Logo Function is turned on by  $n = 1$ , the following trigger commands function only as triggers and do not cut paper. Therefore, it is necessary to register any cut command to the user macro 2.

When the simple Auto Logo Function is turned on by  $n = 2$ , the following cut commands are executed and are the triggers for the simple Auto Logo function.

- <GS> V m: Cut command
- <GS> V m n: Cut command
- <ESC> i: Full cut command (not recommended)
- <ESC> m: Partial cut command (not recommended)

Reference    ESC GS / W, ESC GS / C, ESC GS / 2, ESC GS / 3, ESC GS / 4, ESC GS / 5, ESC GS / 6

**ESC GS / 2 n**

Name	Set command character
Code	ASCII    ESC    GS    /    3    n Hex.       1b    1d    2f    32    n Decimal    27    29    47    50    n
Defined Region	$32 \leq n \leq 127, n = 0$
Initial Value	$n = 0$
Function	Sets the Auto Logo function command character. This command is registered to the non-volatile memory by the "<ESC> <GS> / W" command. This command is ignored when Auto Logo is being executed.

n	Setting
32 to 127	Command Character
0	No Command Character Setting

A command character is a character that is a command for specifying the logo number to print with the Auto Logo printing.

When "/" is specified as the command character, "/2/3" is embedded in the print data.

The printer does not process the "/" as character data but as a command and stores number that follows at the end and prints it as an Auto Logo in the order that it is stored. Therefore, if "/2/3" is embedded, Auto Logo will print Logo2 and Logo3 in that order. If the specified logo has not been registered, logo printing will be ignored.

Also, if there is no set command character setting, a logo will not be printed.

Note that "/2/3" is processed as a command is not printed.

However, using the "<ESC> <GS> /5 n" command it is possible to switch "/2/3" to a space.

In the same way as with "/2/3/2/2" if a logo is duplicated, only the initial logo is printed.

A maximum of 32 logos can be stored as Auto Logos.

Continuing after the command character, the following shows the defined area of the character d that specifies the logo number.

"1"  $\leq$  d  $\leq$  "9" ( $49 \leq d \leq 57$ ) → Logo number 1 to 9

"A"  $\leq$  d  $\leq$  "F" ( $65 \leq d \leq 70$ ) → Logo number 10 to 16

The logo of key codes kc1 and kc2 defined by "GS ( L <fn=67>" or "GS 8 L <fn=67>" is possible to print by the Logo number of this command.

The following table shows the key codes and logo number.

n	kc1	kc2	n	kc1	kc2
"1"	0	1	"9"	0	9
"2"	0	2	"A"	1	0
"3"	0	3	"B"	1	1
"4"	0	4	"C"	1	2
"5"	0	5	"D"	1	3
"6"	0	6	"E"	1	4
"7"	0	7	"F"	1	5
"8"	0	8			

Reference            ESC GS / W, ESC GS / C, ESC GS / 1, ESC GS / 3, ESC GS / 4, ESC GS / 5, ESC GS / 6

**ESC GS / 3 nL nH d1 d2 ... dk**

Name	Set user macro 1								
Code	ASCII	ESC	GS	/	3	nL	nH	d1d2...dk	
	Hex.	1b	1d	2f	33	nL	nH	d1d2...dk	
	Decimal	27	29	47	51	nL	nH	d1d2...dk	
Defined Region	$1 \leq nL \leq 64$								
	nH = 0								
	$1 \leq (nL+nHx256) \leq 64$								
	dk = (nL+nHx256)								
	$0 \leq d \leq 255$								
Initial Value	No user macro 1 setting								
Function	Sets the user macro 1 of the Auto Logo function.								
	This command is registered to the non-volatile memory by the "<ESC> <GS> / W" command.								
	This command is ignored when Auto Logo is being executed.								
	Registers print data in user macro 1.								
	A maximum of 64 bytes of data can be registered.								
	Note that it is prohibited to register Auto Logo command characters in a user macro.								
Reference	ESC GS / W, ESC GS / C, ESC GS / 1, ESC GS / 2, ESC GS / 4, ESC GS / 5, ESC GS / 6								

**ESC GS / 4 nL nH d1 d2 ... dk**

Name	Set user macro 2									
Code	ASCII	ESC	GS	/	4	nL	nH	d1	d2...dk	
	Hex.	1b	1d	2f	34	nL	nH	d1	d2...dk	
	Decimal	27	29	47	52	nL	nH	d1	d2...dk	
Defined Region	$1 \leq nL \leq 64$									
	$nH = 0$									
	$1 \leq (nL+nHx256) \leq 64$									
	$dk = (nL+nHx256)$									
	$0 \leq d \leq 255$									
Initial Value	No user macro 2 setting									
Function	Sets the user macro 2 of the Auto Logo function.									
	This command is registered to the non-volatile memory by the "<ESC> <GS> / W" command.									
	This command is ignored when Auto Logo is being executed.									
	Registers print data in user macro 2.									
	A maximum of 64 bytes of data can be registered.									
	Note that it is prohibited to register Auto Logo command characters in a user macro.									
Reference	ESC GS / W, ESC GS / C, ESC GS / 1, ESC GS / 2, ESC GS / 3, ESC GS / 5, ESC GS / 6									

**ESC GS / 5 n**

Name	Set command character switching method
Code	ASCII    ESC    GS    /    5    n Hex.        1b    1d    2f    35    n Decimal    27    29    47    53    n
Defined Region	$0 \leq n \leq 1$
Initial Value	$n = 0$
Function	Sets the Auto Logo function command character switching method. This command is registered to the non-volatile memory by the "<ESC> <GS> / W" command. This command is ignored when Auto Logo is being executed.

n	Setting
0	Does not print the command character and the following logo number
1	Switches the command character and the following logo number into a space character (0 x 20)

When "/" is specified as the command character, the "/2" embedded in the print data is not a character string, but processed as a command.

At this time, "/2" is processed as a command is not printed.

However, by specifying  $n = 1$  in this command, it is possible to switch "/2" to a space.

Reference	ESC GS / W, ESC GS / C, ESC GS / 1, ESC GS / 2, ESC GS / 3, ESC GS / 4, ESC GS / 6
-----------	--

**ESC GS / 6 n**

Name	Set partial cut before Auto Logo printing					
Code	ASCII	ESC	GS	/	6	n
	Hex.	1b	1d	2f	36	n
	Decimal	27	29	47	54	n
Defined Region	$0 \leq n \leq 1$					
Initial Value	n = 0					
Function	Sets a partial cut before the Auto Logo printing.					
	This command is registered to the non-volatile memory by the "<ESC> <GS> / W" command.					
	This command is ignored when Auto Logo is being executed.					

n	Setting
0	Does not execute a partial cut before the Auto Logo printing.
1	Executes a partial cut before the Auto Logo printing.

When printing Logo2 and Logo3 as Auto Logo printing like the one in the drawing below, this command selects to execute a partial cut before printing Logo2 of the Auto Logo and Logo3.

If a partial cut is executed using this function, it is possible to provide coupons, etc., that are printed using Auto Logo with a partial cut.

Reference ESC GS / W, ESC GS / C, ESC GS / 1, ESC GS / 2, ESC GS / 3, ESC GS / 4, ESC GS / 5

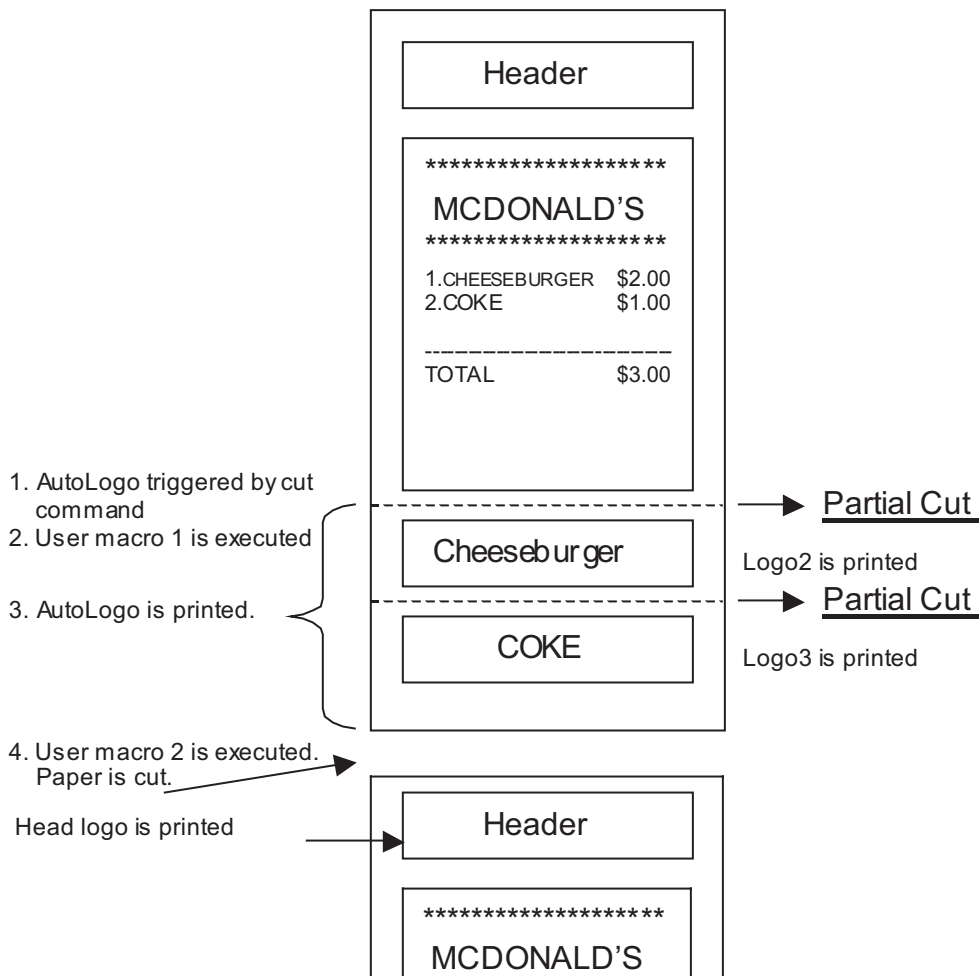

### 4-3-8 STAR Original Buzzer Commands

#### ESC GS BEL m t1 t2

Name	Ring buzzer						
Code	ASCII	ESC	GS	BEL	m	t1	t2
	Hex.	1B	1D	07	m	t1	t2
	Decimal	27	29	7	m	t1	t2
Defined Area	$1 \leq m \leq 2$						
	$1 \leq t1 \leq 255$						
	$1 \leq t2 \leq 255$						
Initial Value	- - -						
Function	Rings the buzzer.						
	m specifies the drive terminal of the buzzer.						

m	Buzzer Drive Terminal
1, 49	Buzzer Drive Terminal 1
2, 50	Buzzer Drive Terminal 2

t1 specifies energizing time; t2 specifies the delay time.

- Energizing time = 20 msec x t1
- Delay time = 20 msec x t2

The buzzer will not ring while printing.

Use of this command other than for ringing the buzzer is prohibited.

(There is the possibility of damage if using this command for driving the drawer on models that support external device terminals.)

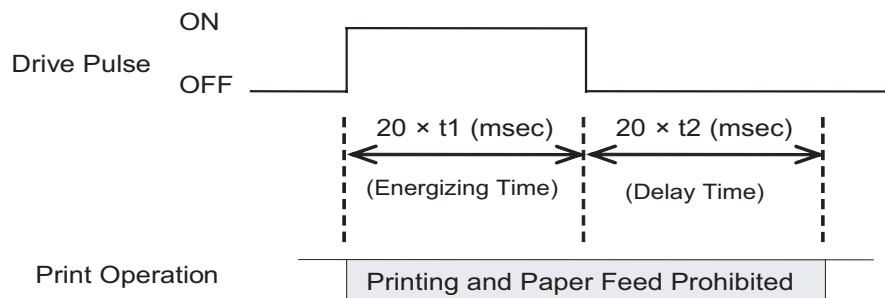



**ESC GS EM DC1 m n1 n2**

Name	External buzzer drive pulse condition settings							
Code	ASCII	ESC	GS	EM	DC1	m	n1	n2
	Hex.	1B	1D	19	11	m	n1	n2
	Decimal	27	29	25	17	m	n1	n2
Defined Area	$1 \leq m \leq 2$		$49 \leq m \leq 50$					
	$0 \leq n1 \leq 255$							
	$1 \leq n2 \leq 255$							
Initial Value	n1=0,n2=0							
Function	Sets external buzzer derive pulse condition.							
	m specifies the buzzer drive terminal to perform the condition settings.							

m	Buzzer Drive Terminal
1, 49	Buzzer Drive Terminal 1
2, 50	Buzzer Drive Terminal 2

n1 specifies the energizing time; n2 specifies the delay time.

- Energizing time:=20msec x n1
- Delay time:=20msec x n2

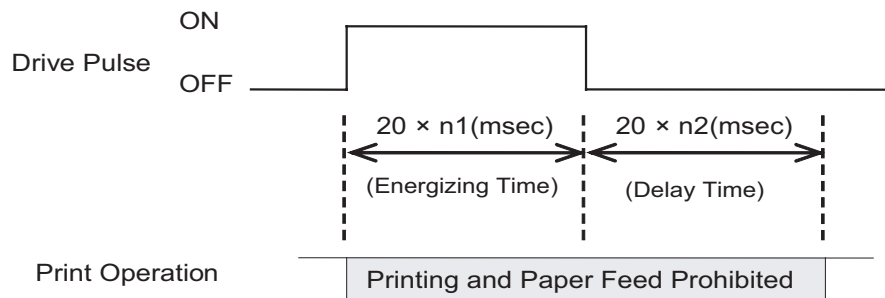

Drives for external buzzers set using this command is performed by <ESC> <GS> <EM> <DC2> m n1 n2.

The setting value is not initialized by <ESC> "@" and <CAN>.

**ESC GS EM DC2 m n1 n2**

Name	External buzzer drive execution							
Code	ASCII	ESC	GS	EM	DC2	m	n1	n2
	Hex.	1B	1D	19	12	m	n1	n2
	Decimal	27	29	25	18	m	n1	n2
Defined Area	$1 \leq m \leq 2$		$49 \leq m \leq 50$					
	$1 \leq n1 \leq 20$							
	N2=0							
Initial Value	---							
Function	Repeatedly drives the buzzer according to the ON/OFF conditions set by the external buzzer drive pulse conditions command <ESC> <GS> <EM> <DC1> m t1 t2. m specifies the buzzer drive terminal to drive.							

m	Buzzer Drive Terminal
1, 49	Buzzer Drive Terminal 1
2, 50	Buzzer Drive Terminal 2

Specifies the number of repetitions of the buzzer drive with  $(n2 \times 256 + n1)$ .

The buzzer will not ring while printing.

This command is prohibited for uses other than to ring the buzzer.

(If this command is used to drive the cash drawer on models that have an external device terminal, the system will be damaged. Absolutely never use it for other purposes.)

The buzzer can be stopped by pressing the paper feed switch or opening the cover when it is ringing.

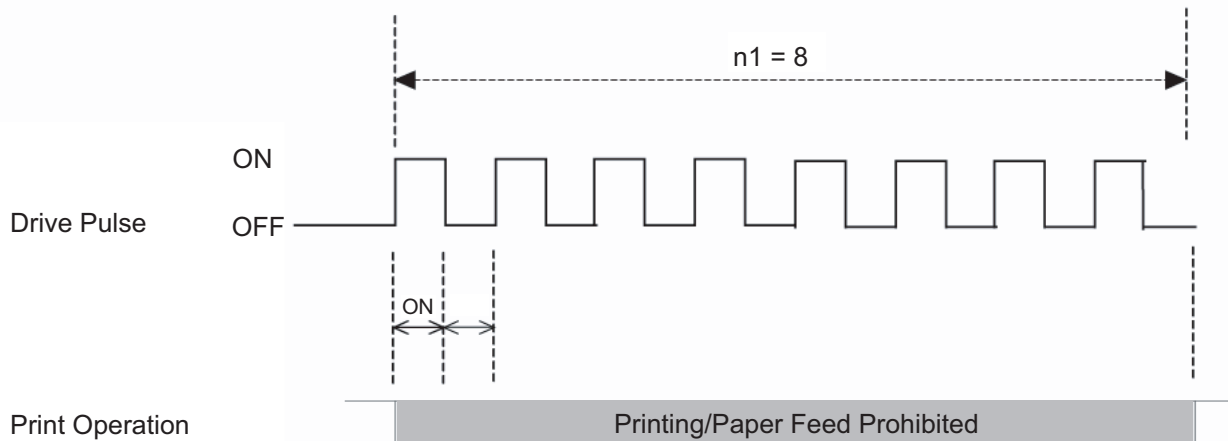
**[EX.]**

(Note) If the off time is set to 0 (zero), it is possible to ring the buzzer continuously for the amount of n1. For example, if on = 5 seconds, off = 0, and n1 = 20 times, the buzzer will ring for 100 seconds.

### 4-3-9 Two-dimensional Bar Code 2D Code PDF417 Command Details

This command prints two-dimensional bar code 2D code PDF417.

There are four types of commands, according to functions, for two-dimensional bar code PDF417.

- |                           |                      |
|---------------------------|----------------------|
| (1) Bar code type setting | (<ESC> <GS> "x" "S") |
| (2) Bar code data setting | (<ESC> <GS> "x" "D") |
| (3) Bar code printing     | (<ESC> <GS> "x" "P") |

The following describes the functions in detail.

#### (1) Bar code type setting

These commands set the bar code type. Because these are all set with default values, they should be used only when it is necessary to change. (Refer to section below for details on each setting.)

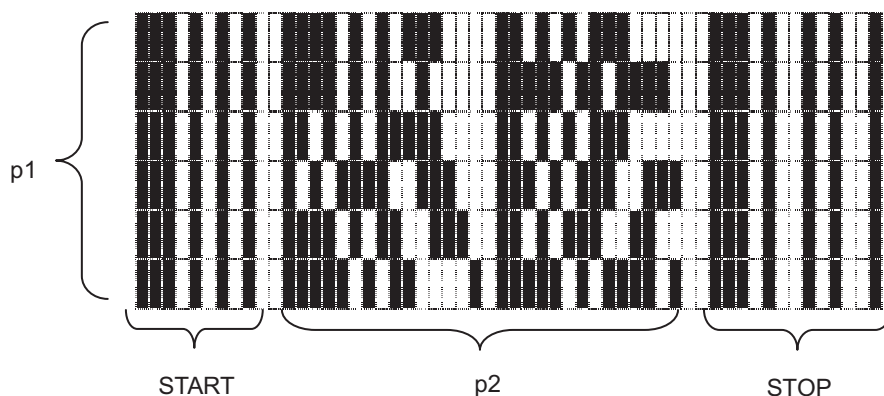

PDF417 is configured by a fixed bar pattern for starting and stopping, and a bar pattern called a code word. Code words are configured by 17 modules.

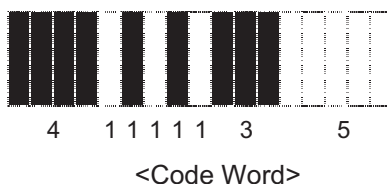

<ESC> <GS> "x" "S" "0" specifies values of p1 and p2.

USE\_LIMITS mode specify the ratio of p1 and p2. USE\_FIXED mode specifies p1 (line count) and p2 (code word count per line).

<ESC> <GS> "x" "S" "1" specifies values of error correction levels.

PDF417 can read information even if a portion of the data is corrupted by using the error correction.

By increasing this level, the bar code size increases because there is more preparatory information.

<ESC> <GS> "x" "S" "2" and <ESC> <GS> "x" "S" "3" specify the size of the module that configures the code word.

The X direction size (in dot increments) is determined by <ESC> <GS> "x" "S" "2" for the module, and <ESC> <GS> "x" "S" "3" specifies the Y direction size from the aspect.

Module size setting is the basis for the bar code image that is generated, so the resulting print will vary according to that setting.

#### Printable size of bar code

Vertical Size [dots]	Horizontal Size [dots]
640	640

The settings above are set individually, so the errors described below may be generated even if there is no particular problem in those settings. In such case, if the bar code is generated the (3) print command (<ESC> <GS> “x” “P”) is ignored.

- Error is generated when generating a bar code, due to the combination of the bar code setting commands.
- The bar code data that is generated exceeds the printable size of PDF417.
- Print data exceeds the currently set print region.

It is recommended to use (4) Bar code expansion information acquisition (<ESC> <GS> “x” “I”) as a means for checking these errors prior to printing.

## **(2) Bar code data setting command**

This command sets the print data of the bar code.

## **(3) Bar code print command**

- Standard mode  
This command prints the bar code according to the settings of (1) and (2).
- Page mode  
This command expands to the bar code image buffer according to the settings of (1) and (2).

### **- Precautions for use of commands -**

- Unless the following operations are performed, the setting values are maintained for (1) and (2).  
This setting value is held between both the standard mode and the page mode.
  - Sending of new setting commands
  - Sending an initializing command (<ESC> @, <CAN>)
  - The power is turned off
- Sent each time for (3).
- Printing
  - When printing, position shifting according to the horizontal tab, absolute position specification, relative position specification, and position alignment is valid.
  - Upside-down printing and two-color printing are possible.
- When a bar code is printed, always verify it by actual use.

Send the command transmission example last.

= ESC/POS standard mode =

#### 1. Bar code type setting

- |                               |  |
|-------------------------------|--|
| <ESC> <GS> “x” “S” “0” 0 2 3: | Sets the bar code size to USE_LIMITS = 2:3 |
| <ESC> <GS> “x” “S” “1” 3:     | Sets ECC level to 3                        |
| <ESC> <GS> “x” “S” “2” 3:     | Sets the module X direction size to 3 dots |
| <ESC> <GS> “x” “S” “3” 3:     | Sets module aspect ratio to 3              |

#### 2. Bar code data setting

- |                                       |                        |
|---------------------------------------|------------------------|
| <ESC> <GS> “x” “D” 10 0 “0123456789”: | Sets the bar code data |
|---------------------------------------|------------------------|

#### 3. Printing bar code

To verify whether printing is possible with the current settings, check the bar code expansion information

- |                     |                                      |
|---------------------|--------------------------------------|
| <ESC> <GS> “x” “I”: | Bar code expansion information check |
| <ESC> <GS> “x” “P”: | Print                                |

= ESC/POS Page Mode =

(1) Specify page mode

<ESC> "L": Select page mode

(2) Set bar code type

<ESC> <GS> "x" "S" "0" 0 2 3: Set bar code size to USE LIMITS = 2:3

<ESC> <GS> "x" "S" "1" 3: Set ECC level to 3

<ESC> <GS> "x" "S" "2" 3: Set module X direction size to 3

<ESC> <GS> "x" "S" "3" 3: Set module aspect ratio to 3

(3) Set bar code data

<ESC> <GS> "x" "D" 10 0 "0123456789": Select bar code data

(4) Print bar code

Check the bar code expansion information to check whether to print using the current settings.

<ESC> <GS> "x" "I": Check bar code expansion information

<ESC> <GS> "x" "P": Expand bar code

<ESC> <FF>: Print

### ESC GS x S 0 n p1 p2

Name	Set PDF417 bar code size								
Code	ASCII	ESC	GS	x	S	0	n	p1	p2
	Hex.	1B	1D	78	53	30	n	p1	p2
	Decimal	27	29	120	83	48	n	p1	p2
Defined Area	n = 0, 1								
	When n = 0: $1 \leq p1 \leq 99, 1 \leq p2 \leq 99$								
	When n = 1: $p1 = 0$ or $3 \leq p1 \leq 90, p2 = 0$ or $1 \leq p2 \leq 30$ (However, this excludes $p1 = p2 = 0$ )								
Initial Value	n = 0, p1 = 1, p2 = 2								
Function	Parameter details								

	n (Specify Method to Specify Bar Code Size)	p1, p2 (Size Specification)
0	USE_LIMITS (Specify ratio of bar code horizontally and vertically)	p1: p2: Proportions of Vertical (p1) and Horizontal (p2) However, p1: p2 = 1: 99 to 10 : 1 (p1/p2 = 0.01 to 10)
1	USE_FIXED (Specifies number of lines and number of columns of bar code.)	p1: Number of lines (0, 3 to 90), p2: Number of columns (0, 1 to 30) However, $p1 * p2 \leq 928$ When either p1 or p2 specifies 0, it indicates that that setting value is variable.

Setting the bar code size using this command specifies the general size of the bar code. The size will automatically be corrected according to the other settings.

### ESC GS x S 1 n

Name	Set PDF417 ECC (security level)						
Code	ASCII	ESC	GS	x	S	1	n
	Hex.	1B	1D	78	53	31	n
	Decimal	27	29	120	83	49	n
Defined Area	$0 \leq n \leq 8$						
Initial Value	n = 1						
Function	Parameter details						
	• n: ECC level (0 to 8)						

**ESC GS x S 2 n**

Name	Set PDF417 module X direction size						
Code	ASCII	ESC	GS	x	S	2	n
	Hex.	1B	1D	78	53	32	n
	Decimal	27	29	120	83	50	n

Defined Area  $1 \leq n \leq 10$

Initial Value  $n = 2$

Function Parameter details

- n: Sets the module X direction size (x-dim). Units: Dots

It is recommended that  $2 \leq n$  when specifying using this command.

When using with  $n = 1$ , check by actual use.

### ESC GS x S 3 n

Name	Set PDF417 module aspect ratio							
Code	ASCII	ESC	GS	x	S	3	n	
	Hex.	1B	1D	78	53	33	n	
	Decimal	27	29	120	83	51	n	

Defined Area  $1 \leq n \leq 10$

Initial Value  $n = 3$

Function Parameter details

- n: Sets the module aspect ratio (asp).

The module Y direction size (x-dim x asp) is set using this command.

It is recommended that  $2 \leq n$  when specifying using this command.

When using with  $n = 1$ , check by actual use.

### ESC GS x D nL nH d1 d2 ... dk

Name	Set PDF417 bar code data											
Code	ASCII	ESC	GS	x	D	nL	nH	d1	d2	...	dk	
	Hex.	1B	1D	78	44	nL	nH	d1	d2	...	dk	
	Decimal	27	29	120	68	nL	nH	d1	d2	...	dk	

Defined Area  $0 \leq nL \leq 255, 0 \leq nH \leq 255$

$1 \leq (nL + nH \times 256) \leq 1024$

$0 \leq d \leq 255$

$1 \leq k \leq 1024$

Initial Value ---

Function Parameter details

- $nL + nH \times 256$ : Bar code data count
- dk : Bar code data (Maximum 1024 data)

When  $[nL + nH \times 256]$  is outside of the definition, data of  $[nL + nH \times 256]$  bytes is discarded.



## ESC GS x P

Name	Print PDF417 bar code				
Code	ASCII	ESC	GS	x	P
	Hex.	1B	1D	78	50
	Decimal	27	29	120	80

Defined Area ---

Initial Value ---

Function This command prints bar code data or expands it to the image buffer.

Also, this command is ignored if the following errors occur.

- When an error is generated when generating a bar code, due to the combination of the bar code setting commands
- When the bar code data that is generated exceeds the printable size of PDF417
- When the print data exceeds the currently set print region

When a bar code is printed, always verify it by actual use.

### Standard mode

If there is unprinted data in the line buffer, after that data is printed, and this command is executed, the bar code is printed. Therefore, it is not possible to print with other data (characters, bit images, or bar codes) existing in the same line.

### Page mode

This command only expands bar code data to the image buffer.

**ESC GS x I**

Name Get PDF417 bar code expansion information

Code ASCII ESC GS x I  
 Hex. 1B 1D 78 49  
 Decimal 27 29 120 73

Defined Area ---

Initial Value ---

Function When printing a bar code with the current settings and at the print starting position using this command, error information is sent from the printer. Therefore, it is possible to check whether it is possible to print before actually printing, by using this command.

If an error occurs, this command is discarded even if the print command (<ESC> <GS> “x” “P”) is sent.

If the following errors occur, “Error” information is sent from the printer.

- When an error is generated when generating a bar code, due to the combination of the bar code setting commands.
- When the bar code data that is generated exceeds the printable size of PDF417.
- When the print data exceeds the currently set print region

Transmission format: <ESC> <GS> “x” “I” n

n	
0	No Error
1	Error

### 4-3-10 STAR Original Print Starting Trigger Control Commands

This command is for models equipped with an expansion control function for page control of line unit commands, by controlling the image buffer by page.

#### ESC GS g 0 m n

Name	Print starting trigger						
Code	ASCII	ESC	GS	g	0	m	n
	Hex.	1B	1D	67	30	m	n
	Decimal	27	29	103	48	m	n
Defined Area	m = 0, n = 0						
Initial Value	---						
Function	Starts printing when there is unprinted data in the image buffer. It is prohibited to send this command while in the raster mode.						

#### ESC GS g 1 m n

Name	Print starting timer						
Code	ASCII	ESC	GS	g	1	m	n
	Hex.	1B	1D	67	31	m	n
	Decimal	27	29	103	49	m	n
Defined Area	m = 0, $0 \leq n \leq 255$						
Initial Value	Depends on the model						
Function	Sets the print starting timer specified at n x 10 msec.  The print starting timer starts measuring from the point where the print data reception stops, and measures up to the set print starting timer.  When the set print starting timer is reached, the printer starts printing if there is unprinted data in the image buffer.  It is prohibited to send this command while in the raster mode.						

n	Operating Mode
0	Print starting timer = initial value
1 to 255	Print starting timer n x 10 msec.

## 4-3-11 STAR Original 2-Dimensional Bar Code QR Code Command Details

\* Note that QR code is a registered trademark of DENSO WEB.

This command is for printing 2-dimensional bar code QR codes. There are four functions of the commands relating to the 2-dimensional bar code QR codes, shown below.

(1) Set bar code type	(<ESC> <GS> “y” “S”)
(2) Set bar code data	(<ESC> <GS> “y” “D”)
(3) Set Star page mode	(<ESC> <GS> “y” “T”)
(4) Print Bar code	(<ESC> <GS> “y” “P”)

The details of each function are described below.

### (1) Set bar code type

These commands set the bar code type. Because all initial values are set, use these only to make changes. (See the details for each setting below.)

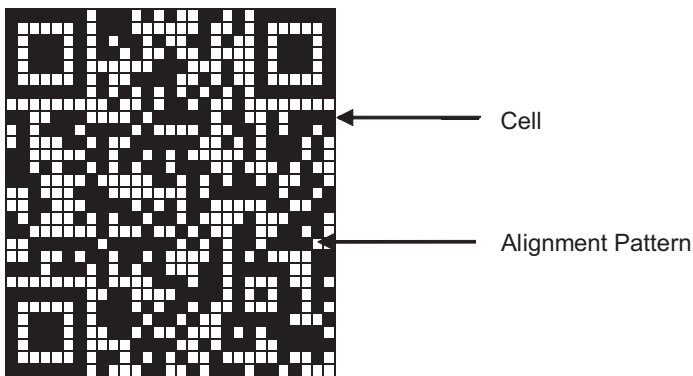

<ESC> <GS> “y” “S” “0” Sets the model

Currently supported models are model 1 and model 2. Model 2 has a configuration including an alignment bar to improve its support of weight to handle skewing when codes are large.

<ESC> <GS> “y” “S” “1” Sets the error correction level

QR codes can be read even if a part of the data is corrupted, by using error correction. Raising this level increases the size of the bar code because there is an increase in preparatory information.

<ESC> <GS> “y” “S” “2” Specifies the size of the cell (One four squared region configuring the QR code)

The QR code is formed into a square of an equivalent size in the vertical and horizontal directions, but the size of the bar code image that is generated depends on the cell size setting. See Appendix 9 for details on the actual printed size of the QR code.

These settings are individual settings. Therefore, even though there may not be any particular problem in each of them, there is the potential for an error to be generated. (See the descriptions below.) In such cases, the bar code will not be generated and the (4) Print command (<ESC> <GS> “y” “P”) is ignored. With the (5) Get bar code expansion information command, an error code is returned.

- Error is generated when generating a bar code by the combination of each setting command.
- Print data exceeds the currently set print region

Therefore, it is recommended to use (5) Get bar code expansion information command (<ESC> <GS> “y” “I”) as a means for checking for these errors prior to printing.

### (2) Set bar code data

This command sets the bar code print data. There are four types of data that can be set using QR codes. They are: numbers; English characters; binary; and Kanji. Furthermore, there are two types of data setting methods. One is to specify these along with the bar code data (data manual analysis), and the other is to specify only the bar code data (data automatic analysis).

### (3) Set Star page mode

This command sets the expansion starting position and rotation information for bar code data expansion.

### (4) Print Bar code

This command prints bar codes based on the settings of (1) to (3).

= Precautions on using these commands =

- The setting values for (1) to (3) are held unless any of the following operations are performed.
  - Sending a new setting command
  - Sending an initialize command (<ESC> @, /)
  - Turning the power OFF
- When there is an error in sending a command with (2), the set data is cleared and the command itself is disabled.
- (4) is sent when necessary.
- Printing:
  - When printing, position movement using specify absolute position, specify relative position, and align position are enabled.
  - Upside down printing and 2-color printing are possible.
- Printed bar codes should always be checked in an actual use.

The following is an example showing the sending of the commands.

#### (1) Set bar code type

<ESC> <GS> "y" "S" "0" 1	Sets to model 1.
<ESC> <GS> "y" "S" "1" 0	Sets mistake correction level to L.
<ESC> <GS> "y" "S" "2" 3	Sets cell size to 3 dots.

#### (2) Set bar code data

• <ESC> <GS> "y" "D" "1" 0 20 0	"2005, January, 1 (SAT)" <LF> Sets bar code data (Data automatic analysis)
---------------------------------	---

Sets bar code data (Data manual analysis)

• <ESC> <GS> "y" "D" "2" 9 1 4 0	"2005" " , "
4 2 0	"Year" " , "
1 1 0	"1" " , "
4 2 0	"Month" " , "
1 1 0	"1" " , "
4 2 0	"Day" " , "
4 2 0	"(" " , "
2 3 0	"SAT" " , "
4 2 0	")" " , "

#### (3) Print bar code

<ESC> <GS> "y" "p"	Print
--------------------	-------

### ESC GS y S 0 n

Name	Set QR code model						
Code	ASCII	ESC	GS	y	S	0	n
	Hex.	1B	1D	79	53	30	n
	Decimal	27	29	121	83	48	n
Defined Area	$1 \leq n \leq 2$						
Initial Value	n = 2						
Function	Sets the model.						
	<ul style="list-style-type: none"> <li>• Parameter details</li> </ul>						

n	Set Model
1	Model 1
2	Model 2

### ESC GS y S 1 n

Name	Set QR code mistake correction level						
Code	ASCII	ESC	GS	Y	S	1	n
	Hex.	1B	1D	79	53	31	n
	Decimal	27	29	121	83	49	n
Defined Area	$0 \leq n \leq 3$						
Initial Value	n = 0						
Function	Sets the mistake correction level.						
	<ul style="list-style-type: none"> <li>• Parameter details</li> </ul>						

n	Mistake Correction Level	Mistake Correction Rate (%)
0	L	7
1	M	15
2	Q	25
3	H	30

### ESC GS y S 2 n

Name	Set QR code cell size						
Code	ASCII	ESC	GS	y	S	2	n
	Hex.	1B	1D	79	53	32	n
	Decimal	27	29	121	83	50	n
Defined Area	$1 \leq n \leq 8$						
Initial Value	n = 3						
Function	Sets the cell size.						
	<ul style="list-style-type: none"> <li>• Parameter details</li> <li>• n: Cell size (Units: Dots)</li> <li>• It is recommended that the specification using this command be <math>3 \leq n</math>.</li> </ul> <p>If n = 1 or 2, check by actually using.</p>						

**ESC GS y D 1 m nL nH d1 d2 ... dk**

Name	Set QR code cell size (Auto Setting)												
Code	ASCII	ESC	GS	y	D	1	m	nL	nH	d1	d2	...	dK
	Hex.	1B	1D	79	44	31	m	nL	nH	d1	d2	...	dK
	Decimal	27	29	121	68	49	m	nL	nH	d1	d2	...	dK
Defined Area	m = 0												
	$0 \leq nL \leq 255, 0 \leq nH \leq 255$												
	$1 \leq nL + nH \times 256 \leq 7089$ (k = nL + nH x 256)												
	$0 \leq d \leq 255$												
Initial Value	---												
Function	Automatically expands the data type of the bar code and sets the data.												
	<ul style="list-style-type: none"> <li>• Parameter details</li> <li>• nL + nH x 256: Byte count of bar code data</li> <li>• dk: Bar code data (Max. 7089 bytes)</li> <li>• When using this command, the printer receives data for the number of bytes (k) specified by nL and nH. The data automatically expands to be set as the bar code data.</li> <li>• Indicates the number bytes of data specified by the nL and nH.</li> </ul> <p>When processing Chinese character (Kanji) codes, two bytes is one character.</p> <ul style="list-style-type: none"> <li>• Command analysis is terminated if the command is outside of the defined area. Bar code data is cleared at this time.</li> <li>• The data storage region of this command is shared with the manual setting command so data is updated each time either command is executed.</li> </ul>												

**ESC GS y D 2 a m1 n1L n1H d11 d12 ... d1k m2 n2L n2H d21 d22 ... d2k ml ... dlk**

Name	Set QR code cell size (Manual setting)													
Code	ASCII	ESC	GS	y	D	2	a	m1	n1L	n1H	d11	d12	...	d1K
	Hex.	1B	1D	79	44	32	a	m1	n1L	n1H	d11	d12	...	d1K
	Decimal	27	29	121	68	50	a	m1	n1L	n1H	d11	d12	...	d1K
	ASCII	m2	n2L	n2H	D21	d22	...	d2K	ml	...	dlk			
	Hex.	m2	n2L	n2H	D21	d22	...	d2K	ml	...	dlk			
	Decimal	m2	n2L	n2H	D11	d22	...	d2K	ml	...	dlk			
Defined Area	$1 \leq a \leq 255$													
	$1 \leq m \leq 4$													
	$0 \leq nL \leq 255, 0 \leq nH \leq 255$													
	$1 \leq nL + nH \times 256 \leq 7089 (k = nL + nH \times 256)$													
	$0 \leq d \leq 255$													
	$1 \leq l \leq 255$													
Initial Value	---													
Function	Specifies the bar code data type and sets the data.													
	• Parameter details													
	• a: Block count													
	• m: Input data type													
	• nL + nH x 256: Bar code data byte count													
• dk: Bar code data (Max. 7089 bytes)														

m	Data Type	Data Definition Region (d)
1	Numbers	"0" to "9"
2	English Characters	“, \$, %, *, +, -, ., /, :, “0” to “9”, “A” to “Z”, “a” to “z”
3	Binary	0x00 to 0xFF
4	Kanji (Shift JIS)	0x8140 to 0x9FFC, 0xE040 to 0xEBBF
		However, the lower 8 bits are 0x40 to 0x7E, and 0x80 to 0xFC



- The printer receives the data type specified by m, and the data of the number of bytes (k) specified by nL and nH, based on the block count specified by a.
- 1 block specified by a indicates m1, n1L, n1H, d11 ••• d1k (data type + data count + bar code data), and by continuously sending these a multiple of times, one bar code data can mix data types.
- It is possible to set a maximum of 255 blocks with one command transmission.
- nL and nH specify the number of bytes of the data, so when using Kanji, calculate that 1 character has 2 bytes.
- If this command is outside of the definition region, immediately stop the command analysis process.

When doing so, the bar code data is cleared.

- This command data storage region is shared with the automatic setting command, so data is updated each time either command is executed.
- When the data type is specified as the English Characters (m=2) and “a” to “z” are transmitted, these are converted to the upper-case “A” to “Z” and the bar code are generated.

### ESC GS y P

Name	Print QR code				
Code	ASCII	ESC	GS	y	P
	Hex.	1B	1D	79	50
	Decimal	27	29	121	80
Defined Area	---				
Initial Value	---				
Function	Prints bar code data.				
	Standard mode				
	When receiving this command, if there is unprinted data in the image buffer, the printer will print the bar code after printing the unprinted print data.				
	Page mode				
	Only expands to bar code data image buffer.				
	A margin of more than 4 cells is required around the QR code. The user should ensure that space.				
	Always check printed bar codes in actual use.				

### ESC GS y I

Name	Get QR code expansion information				
Code	ASCII	ESC	GS	y	I
	Hex.	1B	1D	79	49
	Decimal	27	29	121	73
Defined Area	---				
Initial Value	---				
Function	Sends information on generated image sizes and errors in bar code expansion using the current settings. Therefore, it is possible to check whether printing is possible prior to actual printing. If there is an error in the expanded bar code, this command is ignored even if the expand command (<ESC> <GS> “y” “P”) is sent.				
	In the even that errors like the ones below occurs, “Error” information is sent from the printer.				
	<ul style="list-style-type: none"> <li>• When there is an error in generating a bar code by the combination of bar code setting commands.</li> <li>• When the generated bar code data exceeds the printable size</li> </ul>				

Sending Format: <ESC> <GS> “y” “I” n1 n2

n1 n2	Bar Code Information
0x0000	Error
0x0001 to 0xffff	Size around generated bar code (Units: Dots)

## 4-3-12 STAR Original Page Function Commands

### ESC GS h 0 k m n

Name	180° inversion function							
Code	ASCII	ESC	GS	h	0	k	m	n
	Hex.	1B	1D	68	30	k	m	n
	Decimal	27	29	104	48	k	m	n
Defined Area	$0 \leq k \leq 1$		m=0		n=0			
Initial Value	---							
Function	Enables/disables 180° inversion function							

n	180° Inversion Function
0	Disabled
1	Enabled

#### <180° Inversion Function>

Executes a 180° inversion by a 180° inversion trigger when this function is set.

However, this function is executed on print data built-up in the image buffer.

The 180° inversion function is ignored if there is print data longer than the image buffer.

Also, the 180 degree inversion function is ignored if printing is started by settings other than the following 180 degree inversion trigger while the print startup control is set for each line, if page mode is selected or if a macro is being registered or executed.

This setting is not cleared by <ESC> @ or <CAN>.

#### 180° inversion triggers

- Cut command: <GS> V m n , <GS> V m
- BM detection command: <GS> <FF>, <FF>
- Print start command: <ESC> <GS> g 0 m n

#### Usage example

- 1) 180° inversion function enabled: <ESC> <GS> h 0 k m n (k=0x01,m=0x00,n=0x00)
- 2) Print data transmission: Print data (Print length should be within image buffer length)
- 3) Trigger command transmission: <GS> V m n (Cutter command is 180° inversion trigger.)

**ESC GS h 1 k m n**

Name	Water mark function							
Code	ASCII	ESC	GS	h	1	k	m	n
	Hex.	1B	1D	68	31	k	m	n
	Decimal	27	29	104	49	k	m	n
Defined Area	$0 \leq k \leq 2$		$0 \leq m \leq 2$		$1 \leq n \leq 255$			
Initial Value	---							
Function	Enables/disables water mark function.							

k	Water Mark Function
0	Disabled
1	Enabled Prints 1 logo specified by n at position centered in horizontal and vertical directions.
2	Enabled Repeatedly prints the logo specified by n from top edge of page to bottom edge of page at position centered in horizontal direction.

To make the image appropriate for a water mark, set the logo data forming method to print as the water mark using this setting.

If it is not possible to the appropriate image using this setting, reregister the logo data registered as the water mark after forming it to the appropriate data.

m	Water Mark Data Forming Method
0	Prints logo data specified by n as it is.
1	Prints logo data specified by n 25% for printing.
2	Prints logo data specified by n 12.5% for printing.

Specify the registered logo as the water mark.

n	Logo Number
1-255	Registered logo number If the specified logo number is not registered, the water mark will not be printed.

**<Water Mark Function>**

When the water mark function is enabled, the water mark is printed by a water mark printing trigger.

However, this function is executed on print data built-up within the image buffer length.

Water mark printing is ignored when there is print data beyond the length of the image buffer.

Water mark is ignored when in 2-color mode, page mode, when registering macros and when executing macros if printing is started by anything other than the following water mark triggers. This setting is not cleared by <ESC> @ or <CAN>.

Water mark triggers

- Cut command: <GS> V m n, <GS> V m
- BM detection command: <GS> <FF>, <FF>, <GS> <
- Print start command: <ESC> <GS> g 0 m n

**Usage example**

- 1) Register logo to logo number 1 when using water mark.
- 2) Water mark function enable: <ESC> <GS> h 1 k m n (k=0x02, m=0x01, n=0x01)
- 3) Print data transmission: Print data (Print length should be within image buffer length)
- 4) Trigger command transmission: <GS> V m n (Cutter command is water mark print trigger.)

The logo of key codes kc1 and kc2 defined by “GS ( L <fn=67>” or “GS ( L <fn=67>” is possible to print by the Logo number n of this command.

The following table shows the Key codes and logo number.

<SP> in the table below is space (20H).

n	kc1	kc2
1	0	1
2	0	2
3	0	3
4	0	4
5	0	5
6	0	6
7	0	7
8	0	8
9	0	9
10	1	0
11	1	1
12	1	2
13	1	3
14	1	4
15	1	5
16	1	6
17	1	7
18	1	8
19	1	9
20	2	0
21	2	1
22	2	2
23	2	3
24	2	4
25	2	5
26	2	6
27	2	7
28	2	8
29	2	9
30	3	0
31	3	1
32	3	2
33	3	3
34	3	4
35	3	5
36	3	6
37	3	7
38	3	8
39	3	9
40	4	0
41	4	1
42	4	2
43	4	3
44	4	4
45	4	5
46	4	6
47	4	7
48	4	8
49	4	9
50	5	0
51	5	1
52	5	2
53	5	3
54	5	4
55	5	5
56	5	6
57	5	7
58	5	8
59	5	9
60	6	0
61	6	1
62	6	2
63	6	3

n	kc1	kc2
64	6	4
65	6	5
66	6	6
67	6	7
68	6	8
69	6	9
70	7	0
71	7	1
72	7	2
73	7	3
74	7	4
75	7	5
76	7	6
77	7	7
78	7	8
79	7	9
80	8	0
81	8	1
82	8	2
83	8	3
84	8	4
85	8	5
86	8	6
87	8	7
88	8	8
89	8	9
90	9	0
91	9	1
92	9	2
93	9	3
94	9	4
95	9	5
96	9	6
97	9	7
98	9	8
99	9	9
100	<SP>	<SP>
101	<SP>	!
102	<SP>	“
103	<SP>	#
104	<SP>	\$
105	<SP>	%
106	<SP>	&
107	<SP>	'
108	<SP>	(
109	<SP>	)
110	<SP>	*
111	<SP>	+
112	<SP>	.
113	<SP>	-
114	<SP>	.
115	<SP>	/
116	<SP>	0
117	<SP>	1
118	<SP>	2
119	<SP>	3
120	<SP>	4
121	<SP>	5
122	<SP>	6
123	<SP>	7
124	<SP>	8
125	<SP>	9
126	<SP>	:
127	<SP>	;

n	kc1	kc2
128	<SP>	<
129	<SP>	=
130	<SP>	>
131	<SP>	?
132	<SP>	@
133	<SP>	A
134	<SP>	B
135	<SP>	C
136	<SP>	D
137	<SP>	E
138	<SP>	F
139	<SP>	G
140	<SP>	H
141	<SP>	I
142	<SP>	J
143	<SP>	K
144	<SP>	L
145	<SP>	M
146	<SP>	N
147	<SP>	O
148	<SP>	P
149	<SP>	Q
150	<SP>	R
151	<SP>	S
152	<SP>	T
153	<SP>	U
154	<SP>	V
155	<SP>	W
156	<SP>	X
157	<SP>	Y
158	<SP>	Z
159	<SP>	[
160	<SP>	¥
161	<SP>	]
162	<SP>	^
163	<SP>	_
164	<SP>	`
165	<SP>	a
166	<SP>	b
167	<SP>	c
168	<SP>	d
169	<SP>	e
170	<SP>	f
171	<SP>	g
172	<SP>	h
173	<SP>	i
174	<SP>	j
175	<SP>	k
176	<SP>	l
177	<SP>	m
178	<SP>	n
179	<SP>	o
180	<SP>	p
181	<SP>	q
182	<SP>	r
183	<SP>	s
184	<SP>	t
185	<SP>	u
186	<SP>	v
187	<SP>	w
188	<SP>	x
189	<SP>	y
190	<SP>	z
191	<SP>	{

n	kc1	kc2
192	<SP>	
193	<SP>	}
194	<SP>	~
195	!	<SP>
196	!	!
197	!	“
198	!	#
199	!	\$
200	!	%
201	!	&
202	!	'
203	!	(
204	!	)
205	!	*
206	!	+
207	!	.
208	!	-
209	!	.
210	!	/
211	!	0
212	!	1
213	!	2
214	!	3
215	!	4
216	!	5
217	!	6
218	!	7
219	!	8
220	!	9
221	!	:
222	!	:
223	!	<
224	!	=
225	!	>
226	!	?
227	!	@
228	!	A
229	!	B
230	!	C
231	!	D
232	!	E
233	!	F
234	!	G
235	!	H
236	!	I
237	!	J
238	!	K
239	!	L
240	!	M
241	!	N
242	!	O
243	!	P
244	!	Q
245	!	R
246	!	S
247	!	T
248	!	U
249	!	V
250	!	W
251	!	X
252	!	Y
253	!	Z
254	!	[
255	!	¥

### 4-3-13 Star Original Reduced Printing Function Command

#### ESC GS c h v

Name	Set reduced printing					
Code	ASCII	ESC	GS	c	h	v
	Hex.	1B	1D	63	h	v
	Decimal	27	29	99	h	v
Defined Area	$0 \leq h \leq 255$ $0 \leq v \leq 255$					
Initial Value	h = 0 (Horizontal direction reduced printing setting invalid) v = 0 (Vertical direction reduced printing setting invalid)					
Function	Set reduced printing					

h	Set horizontal direction reduced printing
0	Invalid
1	Valid (67%)
2 - 255	Command ignored

v	Set vertical direction reduced printing
0	Invalid
1	Valid (50%)
2 - 255	Command ignored

- Reduced printing in the horizontal direction compresses the entire horizontal direction 67%.
- Reduced printing in the vertical direction prints in Double Resolution mode, so this is invalid in low peak current mode and powered USB I/F.
- Disabled in Page Mode.
- Reduced printing of barcodes can be enabled or disabled by memory switch setting.  
However, cares must be taken as the print position other than the barcode is affected if reduced printing is disabled.

## 4-3-14 STAR Original Text Search Commands

### ESC GS ) B pL pH fn [parameter]

Name	Set text search							
Code	ASCII	ESC	GS	)	B	pL	pH	fn[parameter]
	Hex.	1B	1D	29	42	pL	pH	fn[parameter]
	Decimal	27	29	41	66	pL	pH	fn[parameter]

- Function Runs processes related to text search.
- pL and pH specify the parameter count (pL + pH x 256) in bytes after fn.
  - See the function specifications for details on [parameter].

fn	Function No	Function Name
48	Function 48	Enable and disables text search
49	Function 49	Set the number of times to run the text search macro
50	Function 50	Set to print the string that matches in the text search
64	Function 64	Define the text search string
65	Function 65	Define the text search macro
66	Function 66	Define the timing of the text search macro execution
80	Function 80	Register text search settings and definitions in the non-volatile memory
81	Function 81	Initialize text search settings and definitions
96	Function 96	Print the text search settings and definitions
97	Function 97	Run the text search macro

#### < Text search functional overview >

Determines whether a string registered in the printer in advance is in the print data.

If it is included, run a text search macro that corresponds to that string after or before running the following trigger command.

- Execute cuts by continuous <LF>.
- <GS> "V"

< Text search functional overview >

The following gives an example of command transmission used to set the printer to print the “first logo” at the end of receipt when the print data contains a character string “Cheese burger”.

		Function No.	Contents
1	1C 71 ..	--	Register the logo as the first logo (see FS q).
2	1B 1D 29 42 02 00 51 00	Function 81	Initialize the settings and definitions of functions 48, 49, 50, 64, 65, and 66.
3	1B 1D 29 42 02 00 30 01	Function 48	Enable text searching.
4	1B 1D 29 42 02 00 31 00	Function 49	Set the text search macro to run once.
5	1B 1D 29 42 02 00 32 00	Function 50	Configure the print setting for the matched text string such that the matched text string is printed.
6	1B 1D 29 42 11 00 40 01 01 0D 43 68 65 65 73 65 20 62 75 72 67 65 72	Function 64	Set the text search string with string number 1 to “Cheese burger,” and set the text search macro that is executed when this string is included to text search macro 1.
7	1B 1D 29 42 08 00 41 01 04 00 1C 70 01 00	Function 65	Define text search macro 1 as a command to print logo 1 (see FS p).
8	1B 1D 29 42 03 00 42 01 01	Function 66	Set the execution time for the text search macro that is executed when text search string 1 is included (text search macro 1 in this case) to immediately before cutting.
9	1B 1D 29 42 02 00 60 00	Function 96	Print the settings and definitions of functions 48, 49, 50, 64, 65, and 66. Check the settings and definitions.
10	1B 1D 29 42 02 00 61 01	Function 97	Check the settings and definitions. Make sure the macro runs properly.
11	.. 43 68 65 65 73 65 20 62 75 72 67 65 72 .. 0A 1D 56 42 00	--	Send print data that includes a string such as that shown in fig. 1 (“Cheese burger”) and a trigger command, and check to make sure that the printed result is similar to fig. 2.
12	1B 1D 29 42 02 00 50 00	Function 80	Register the text search settings and definitions to non-volatile memory. After you make sure that everything works properly, use this command to register the text search settings and definitions to non-volatile memory. Afterward, even if you do not send commands 1 to 10, you can obtain a printed result such as that shown in fig. 2 simply by sending print data such as that shown in fig. 1.

Before setting the text search

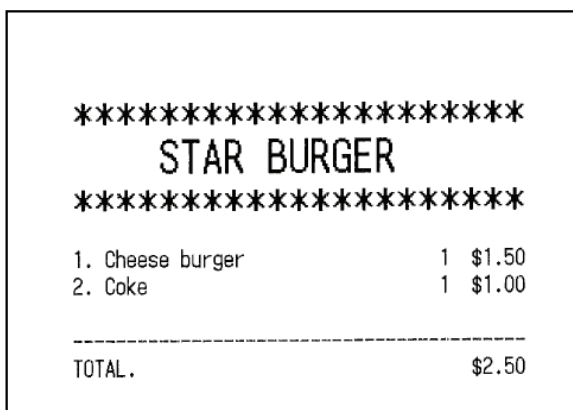

After setting the text search



The first logo is printed because the data contains the string “Cheese burger”.



### <Function 48> ESC GS ) B pL pH fn m (fn = 48)

Name	Enable and disables text search									
Code	ASCII	ESC	GS	)	B	pL	pH	fn	m	
	Hex.	1B	1D	29	42	pL	pH	fn	m	
	Decimal	27	29	41	66	pL	pH	fn	m	

Defined Region pL = 2, pH = 0  
fn = 48  
m=0, 1

Initial Value Depends on setting registered in the non-volatile memory (At the time of shipment: m = 0)

Function Makes text searches valid or invalid.

m	Set
0	Invalid
1	Valid

When text search is valid, determines whether a string registered in the printer in advance is in the print data.

If it is included, run a text search macro that corresponds to that string before or after running the following trigger command.

- Execute cuts by continuous <LF>.
- <GS> "V"
- <ESC> "i"
- <ESC> "m"

No setting when the parameter is not a valid value.

This setting is applied to printer operations when this command is processed.

This setting is registered to non-volatile memory by the ESC GS ) B <Function 80> command.

This command is ignored when the text search macro is running.

Disabled in Page Mode.

**<Function 49> ESC GS ) B pL pH fn m (fn = 49)**

Name	Set the number of times to run the text search macro									
Code	ASCII	ESC	GS	)	B	pL	pH	fn	m	
	Hex.	1B	1D	29	42	pL	pH	fn	m	
	Decimal	27	29	41	66	pL	pH	fn	m	

Defined Region pL = 2, pH = 0  
fn = 49  
m=0, 1

Initial Value Depends on setting registered in the non-volatile memory (At the time of shipment: m = 0)

Function Sets the number of times to run the text search macro when the strings match.

m	Set
0	Run one time
1	Run for the number of times strings match

No setting when the parameter is not a valid value.

This setting is applied to printer operations when this command is processed.

This setting is registered to non-volatile memory by the ESC GS ) B <Function 80) command.

This command is ignored when the text search macro is running.

Disabled in Page Mode.

**<Function 50> ESC GS ) B pL pH fn m (fn = 50)**

Name	Set to print the string that matches in the text search									
Code	ASCII	ESC	GS	)	B	pL	pH	fn	m	
	Hex.	1B	1D	29	42	pL	pH	fn	m	
	Decimal	27	29	41	66	pL	pH	fn	m	

Defined Region pL = 2, pH = 0  
fn = 50  
m=0, 1, 2

Initial Value Depends on setting registered in the non-volatile memory (At the time of shipment: m = 0)

Function Sets the string print operation when strings match.

m	Set
0	Prints the string
1	Does not print the string
2	Switches the string with a blank character

No setting when the parameter is not a valid value.

This setting is applied to printer operations when this command is processed.

This setting is registered to non-volatile memory by the ESC GS ) B <Function 80) command.

This command is ignored when the text search macro is running.

Disabled in Page Mode.

**<Function 64> ESC GS ) B pL pH fn m k d1...dk (fn = 64)**

Name	Define the text search string													
Code	ASCII	ESC	GS	)	B	pL	pH	fn	n	m	k	d1	...	dk
	Hex.	1B	1D	29	42	pL	pH	fn	n	m	k	d1	...	dk
	Decimal	27	29	41	66	pL	pH	fn	n	m	k	d1	...	dk
Defined Region	$4 \leq (pL + pH \times 256) \leq 65535$ ( $0 \leq pL \leq 255, 0 \leq pH \leq 255$ ) $fn = 64$ $1 \leq n \leq 100$ $1 \leq m \leq 100$ $0 \leq k \leq 32$ $32 \leq d \leq 255$													
Initial Value	Depends on setting registered in the non-volatile memory (At the time of shipment: no string definition)													
Function	Defines the text search string for number n. If the text search string for number n is already defined, it is overwritten. M specifies the text search macro number to run. K specifies the size of the defined data in bytes. d specifies the defined data. When the parameter has an invalid value, no definition. This definition is applied to printer operations when this command is processed. This definition is registered to non-volatile memory by the ESC GS ) B <Function 80> command. This command is ignored when the text search macro is running. Disabled in Page Mode.													

**<Function 65> ESC GS ) B pL pH fn m k1 k2 d1...dk (fn = 65)**

Name	Define the text search macro
Code	ASCII    ESC    GS    )    B    pL    pH    fn    m    k1    k2    d1    ...    dk
	Hex.        1B    1D    29    42    pL    pH    fn    m    k1    k2    d1    ...    dk
	Decimal    27    29    41    66    pL    pH    fn    m    k1    k2    d1    ...    dk
Defined Region	$4 \leq (pL + pH \times 256) \leq 65535$ ( $0 \leq pL \leq 255, 0 \leq pH \leq 255$ ) fn = 65 $1 \leq m \leq 100$ $0 \leq (k = k1 + k2 \times 256) \leq 7680$ ( $0 \leq k1 \leq 255, 0 \leq k2 \leq 30$ ) (Size of defined area = 7,680 bytes) $0 \leq d \leq 255$
Initial Value	Depends on setting registered in the non-volatile memory (At the time of shipment: no text search macro definition)
Function	Defines the text search macro for number m. If the text search macro for number m is already defined, it is overwritten. (k = k1 + k2 x 256) specifies the size of the defined data in bytes. d specifies the defined data. If the parameter has an invalid value, processing of this command ends at that point. This definition is applied to printer operations when this command is processed. This definition is registered to non-volatile memory by the ESC GS ) B <Function 80> command. This command is ignored when the text search macro is running. Disabled in Page Mode.

**<Function 66> ESC GS ) B pL pH fn n t (fn = 66)**

Name	Define the text search macro
Code	ASCII    ESC    GS    )    B    pL    pH    fn    n    t Hex.        1B    1D    29    42    pL    pH    fn    n    t Decimal    27    29    41    66    pL    pH    fn    n    t
Defined Region	pL = 3, pH = 0 fn = 66 1 ≤ n ≤ 100 t = 0, 1
Initial Value	Depends on setting registered in the non-volatile memory (At the time of shipment: Soon after cutting)
Function	Sets when to execute a text search macro when there is a match for text search string n.

t	Setting
0	soon after cutting
1	soon before cutting

No setting when the parameter is not a valid value.

This setting is applied to printer operations when this command is processed.

This setting is registered to non-volatile memory by the ESC GS ) B <Function 80) command.

This command is ignored when the text search macro is running.

Disabled in Page Mode.

**<Function 80> ESC GS ) B pL pH fn m (fn = 80)**

Name Register text search settings and definitions in the non-volatile memory

Code	ASCII	ESC	GS	)	B	pL	pH	fn	m
	Hex.	1B	1D	29	42	pL	pH	fn	m
	Decimal	27	29	41	66	pL	pH	fn	m

Defined Region pL = 2, pH = 0  
fn = 80  
m = 0

Initial Value ---

Function Registers the text search setting to non-volatile memory.  
The following shows the contents to register.

Function No	Contents
Function 48	Enable and disables text search
Function 49	Set the number of times to run the text search macro
Function 50	Set to print the string that matches in the text search
Function 64	Define the text search string
Function 65	Define the text search macro
Function 66	Define the timing of the text search macro execution
Function 81	Initialize text search settings and definitions

After registration ends, resets the printer.

The printer operates by reading the setting registered using this command the next time the printer power is turned on.

This command is ignored when the text search macro is running.

Consider the life of the non-volatile memory and avoid over-sue of this command.

Disabled in Page Mode.

### <Function 81> ESC GS ) B pL pH fn m (fn = 81)

Name	Initialize text search settings and definitions									
Code	ASCII	ESC	GS	)	B	pL	pH	fn	m	
	Hex.	1B	1D	29	42	pL	pH	fn	m	
	Decimal	27	29	41	66	pL	pH	fn	m	

Defined Region pL = 2, pH = 0  
fn = 81  
m = 0

Initial Value ---

Function Initialize text search settings and definitions  
The following shows the contents to initialize.

Function No	Contents	Initial Value
Function 48	Enable and disables text search	Invalid
Function 49	Set the number of times to run the text search macro	1 time
Function 50	Set to print the string that matches in the text search	Prints the string
Function 64	Define the text search string	No text search string definition
Function 65	Define the text search macro	No text search macro definition
Function 66	Define the timing of the text search macro execution	soon after cutting

This setting is applied to printer operations when this command is processed.

This setting is registered to non-volatile memory by the ESC GS ) B <Function 80) command.

This command is ignored when the text search macro is running.

Disabled in Page Mode.



### <Function 96> ESC GS ) B pL pH fn m (fn = 96)

Name	Print the text search settings and definitions									
Code	ASCII	ESC	GS	)	B	pL	pH	fn	m	
	Hex.	1B	1D	29	42	pL	pH	fn	m	
	Decimal	27	29	41	66	pL	pH	fn	m	
Defined Region	pL = 2, pH = 0									
	fn = 96									
	m = 0									
Initial Value	---									
Function	Prints text search settings and definitions									
	The following shows the contents to print.									

Function No	Contents
Function 48	Enable and disables text search
Function 49	Set the number of times to run the text search macro
Function 50	Set to print the string that matches in the text search
Function 64	Define the text search string
Function 65	Define the text search macro
Function 66	Define the timing of the text search macro execution

The text search macro is not run at this time.

This command is ignored when the text search macro is running.

Disabled in Page Mode.

### <Function 97> ESC GS ) B pL pH fn m (fn = 97)

Name	Run the text search macro									
Code	ASCII	ESC	GS	)	B	pL	pH	fn	m	
	Hex.	1B	1D	29	42	pL	pH	fn	m	
	Decimal	27	29	41	66	pL	pH	fn	m	
Defined Region	pL = 2, pH = 0									
	fn = 97									
	$1 \leq m \leq 100$									
Initial Value	---									
Function	Runs the text search macro for number m.									
	This command is ignored when the text search macro is running.									

Disabled in Page Mode.

## 4-3-15 Star Original Printer Information Transmission Commands

### ESC GS ) I pL pH fn [parameter]

Name	Set graphics data							
Code	ASCII	ESC	)	I	pL	pH	fn	[parameter]
	Hex.	1B	29	49	pL	pH	fn	[parameter]
	Decimal	27	41	73	pL	pH	fn	[parameter]
Function	Executes printer information processing.							
	<ul style="list-style-type: none"> <li>• pL and pH specify the parameter count (pL + pH x 256) in bytes after fn.</li> <li>• See the function specifications for details on [parameter].</li> </ul>							

fn	Function No	Function Name
48	Function 48	Send the all kind of multibyte fonts

**<Function 48> ESC GS ) I pL pH fn d1 d2**

Name	Send the all kind of multibyte fonts									
Code	ASCII	ESC	GS	)	I	pL	pH	fn	d1	d2
	Hex.	1B	1D	29	49	pL	pH	fn	d1	d2
	Decimal	27	29	41	73	pL	pH	fn	d1	d2

Defined Region pL = 3, pH = 0  
fn = 48  
d1 = 0, d2 = 0

Function Sends the all kind of multibyte font in the printer.

Details Sends in the following format.

ESC GS ) I pL pH fn k1 k2 [multibyte font kind1, multibyte font kind2, ..... ] LF NUL

k1 and k2 indicate the number of transmission data bytes ( $k1 + k2 * 256$ ) after the multibyte font types.

When there are multiple multibyte font types in the printer, they are delimited by commas (2Ch).

The kind of multibyte font is sent as character string data.

Kind of multibyte fonts	Transmitting string
Japanese	KANJI JAPANESE
Simplified Chinese GB2312	CHINA GB2312
Simplified Chinese GB18030	CHINA GB18030
Traditional Chinese BIG5	TAIWAN BIG-5
Korean	KOREA C-5601C

Exemple: When "Simplified Chinese GB18030" and "Traditional Chinese BIG5 " are installed in the printer:

ESC GS ) I pL pH fn k1 k2 CHINA GB18030 , TAIWAN BIG-5 , LF NUL

(k1 = 29, k2 =0)

When the multibyte font is not installed in the printer, the following data is sent:

ESC GS ) I pL pH fn k1 k2 LF NUL

(k1 = 2, k2 =0)

## 4-3-16 Star Original Individual Logo Commands

### ESC GS ) L pL pH fn [parameter]

Name Set graphics data

Code ASCII ESC ) L pL pH fn [parameter]

Hex. 1B 29 4C pL pH fn [parameter]

Decimal 27 41 76 pL pH fn [parameter]

Function Executes graphics data processing.

- pL and pH specify the parameter count (pL + pH x 256) in bytes after fn.
- See the function specifications for details on [parameter].

fn	Function No	Function Name
48	Function 48	Send the registered individual logo CRC
49	Function 49	Send the registered individual NV graphics memory capacity
50	Function 50	Send all key code of the registered NV graphics

### <Function 48> ESC GS ) L pL pH fn kc1 kc2

Name	Send the registered individual logo CRC
Code	ASCII    ESC GS ) L pL pH    fn kc1 kc2
	Hex.     1B 1D 29 4C pL pH    fn kc1 kc2
	Decimal 27 29 41 76 pL pH    fn kc1 kc2
Defined Region	pL = 3, pH = 0 fn = 48 $32 \leq kc1 \leq 126$ , $32 \leq kc2 \leq 126$
Function	Sends a CRC of the logo already stored in the printer.

- Details
- The CRC operation is used only for the logo graphics data currently stored in the printer.
  - The key codes, size and color information are excluded from the CRC operation.
  - When the printer receives the command, it calculates the CRC and sends it.
  - If a logo containing multiple colors is stored, the logo data of the “n+1” color is added after the logo data of the “n-th” color and calculated.
  - The CRC operation is as follows.

CRC16:            Polynomial =  $x^{16} + x^{15} + x^2 + x^0$   
                       Initial value:        FFFF (Hex)  
                       Shift direction:      Right  
                       Output XOR:            FFFF (Hex)

\* See the sample codes for concrete implementation examples.

- The CRC of only the stored logo can be sent by the “GS ( L” or “GS 8 L” command.
- When logo data is stored, the CRC of the received data is operated.
- If the logo data exceeds the horizontal print area, the CRC is operated based on the data that is received when logo data is stored.
- A CRC of the logo, stored by the “FS q” command, cannot be sent.

The CRC is sent in the following format:

ESC GS ) L pL pH fn kc1 kc2 CRC-data LF NUL

\* The CRC data is converted into a character string and sent.

If a unregistered key code is specified, the following data is sent instead:

ESC GS ) L pL pH fn kc1 kc2 LF NUL

### <Command processing flow>

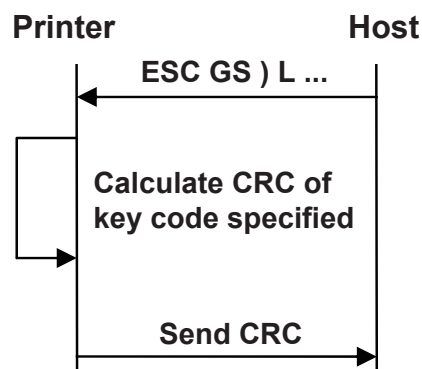

<CRC calculation procedure, sample codes, C language>

```
#define CRC16 0xA001

unsigned int CalcCrc16( int size, unsigned char data[] )
{
    unsigned int result;
    int i,j;

    result = 0xFFFF;

    for( i=0 ; i<size; i++)
    {
        result ^= data[i];
        for(j = 0x0001; j < 0x0100; j = j << 1)
        {
            if( result & 0x0001 )
            {
                result >>= 1;
                result ^= CRC16;
            }
            else
            {
                result >>= 1;
            }
        }
    }
    result = (~result) & 0xFFFF;
    return result;
}
```

Notes

- If a logo is registered by the “FS q” command, the logo data already existing is erased.
- If a logo is registered by the “GS (L” or “GS 8 L” command, the logo that has been registered by the “FS q” command is erased and the new one is registered.

Reference

GS ( L, GS 8 L

**<Function 49> ESC GS ) L pL pH fn kc1 kc2**

Name Send the registered individual logo CRC

Code ASCII ESC GS ) L pL pH fn kc1 kc2  
 Hex. 1B 1D 29 4C pL pH fn kc1 kc2  
 Decimal 27 29 41 76 pL pH fn kc1 kc2

Defined Region pL = 3, pH = 0  
 fn = 49  
 $32 \leq kc1 \leq 126, 32 \leq kc2 \leq 126$

Function Send the individual used capacity of NV graphics already stored in the printer.

- Details
- The used capacity is the total number of bytes of the used region.
  - The management data (14 bytes) are also included in the use capacity.
  - The only NV graphics memory capacity, stored by the “GS ( L” or “GS 8 L” command, cannot be sent.
  - The NV graphics memory capacity, stored by the “FS q” command, cannot be sent.

Sends the used capacity in the following format:

ESC GS ) L pL pH fn kc1 kc2 [ used capacity ] LF NUL

Ex.: When the used capacity is 1200 bytes:

“120” (Hex:31H, 32H, 30H, 30H, Decimal:49, 50, 48, 48) is converted to 4-bytes of data.

If a unregistered key code is specified, the following data is sent instead:

ESC GS ) L pL pH fn kc1 kc2 LF NUL

Reference GS ( L, GS 8 L

## <Function 50> ESC GS ) L p L pH fn d1 d2

Name	Send all key code of the registered NV graphics
Code	ASCII        ESC GS ) L p L pH fn d1 d2 Hex.         1B 1D 29 4C pL pH fn d1 d2 Decimal      27 29 41 76 pL pH fn d1 d2
Defined Region	pL = 3, pH = 0 fn = 50 d1 = 0, d2 = 0
Function	Send all key code of NV graphics already stored in the printer.
Details	<p>Specification A</p> <ul style="list-style-type: none"> <li>• All key code of only NV graphics, stored by the “GS ( L” or “GS 8 L” command, cannot be sent.</li> <li>• All key code of NV graphics, stored by the “FS q” command, cannot be sent.</li> </ul> <p>Sends all key code in the following format:</p> <p>ESC GS ) L pL pH fn kc1 kc2 [ key code key code .... ] LF NUL</p> <p>Where, k1 and k2 indicate the number of data bytes (<math>k1 + k2 * 256</math>) transmitted after the key codes.</p> <p>Ex.: When a NV graphics with key codes 01 and 02 is registered,              and <math>k1 = 6, k2 = 0</math>, [“key code” key code” ...] is “0102” (Hex: 30h, 31h, 30h, 32h; Decimal: 48, 49, 48, 50)</p> <p>When no NV graphics is registered, the following is transmitted.</p> <p>ESC GS ) L pL pH fn k1 k2 LF NUL (Where, <math>k1 = 2, k2 = 0</math>)</p> <p>Specification B</p> <ul style="list-style-type: none"> <li>- If NV graphics are registered with “GS ( L” or “GS 8 L” command, all of their key codes can be sent.</li> <li>- If NV graphics are registered with “FS q” command, none of their key codes can be sent.</li> </ul> <p>All key codes are sent in the following format.</p> <p>ESC GS ) L pL pH fn k1 k2 [key-code key-code ...] LF NUL</p> <p>Up to 512 key codes can be sent, but logo key codes exceeding this limit are not sent.</p> <p>k1 and k2 represent the number of transmission data bytes (<math>k1+k2*256</math>) after the key codes.</p> <p>Example: If NV graphics of key codes 01 and 02 are registered, <math>k1=6</math> and <math>k2=0</math>. [key-code key-code...] is “0102” (30h, 31h, 30h, 32h in Hex; and 48, 49, 48, 50 in Decimal).</p> <p>If NV graphics are not registered, the following data is sent.</p> <p>ESC GS ) L pL pH fn k1 k2 LF NUL (where, <math>k1=2</math> and <math>k2=0</math>)</p> <p>If the USB interface is used, the NSB must be made invalid.</p>
Reference	GS ( L, GS 8 L



## 4-3-17 Star Original Audio Commands

### ESC GS s O z a n c1 c2 d1 d2 t1 t2

Name	Playback NV Audio													
Code	ASCII	ESC	GS	s	O	z	a	n	c1	c2	d1	d2	t1	t2
	Hex.	1B	1D	73	4F	z	a	n	c1	c2	d1	d2	t1	t2
	Decimal	27	29	115	79	z	a	n	c1	c2	d1	d2	t1	t2

Defined Region Z = 0  
 a = 0, 1, 48, 49  
 $1 \leq n \leq 255$   
 $1 \leq c1 + c2 \times 256 \leq 65535$   
 $0 \leq d1 + d2 \times 256 \leq 65535$   
 $0 \leq t1 + t2 \times 256 \leq 65535$

Initial Value ---

Function Plays back the specified NV audio.  
 a specifies the area where the audio data to playback is stored.

a	Audio data storage area
1, 49	User area

n specifies the audio number to playback.  
 $(c1 + c2 \times 256)$  specifies the number of times.  
 $(d1 + d2 \times 256)$  specifies the delay time.  
 Delay time is the time from starting to process this command to the start of audio playback (in seconds).  
 $(t1 + t2 \times 256)$  specifies the interval time.  
 Interval time is the time from the end of the previous audio to the start of the next audio (in seconds).

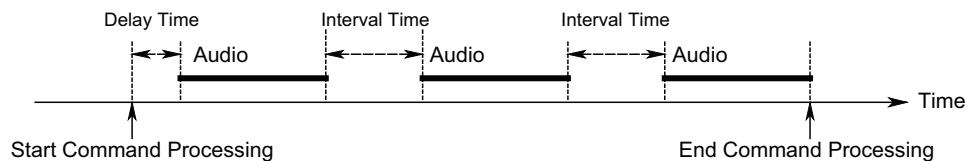

If audio is already being played back, playback after waiting for the end of the audio.

If the printer is printing, playback after printing is ended.

When the parameter has an invalid value, there is no audio playback.

If the audio data of the specified audio number has not been registered, there will be no playback.

Audio will stop by inputting the FEED switch while there is audio playback using this command.

Audio will stop using the NV audio stop command (ESC GS s P) while there is audio playback using this command.

### ESC GS s P

Name	Stop NV Audio					
Code	ASCII	ESC	GS	s	P	
	Hex.	1B	1D	73	50	
	Decimal	27	29	115	80	
Defined Region	---					
Initial Value	---					
Function	<p>Stops audio playback for the following reasons.</p> <ul style="list-style-type: none"> <li>• NV audio playback command ESC GS s O</li> <li>• NV audio lump playback command ESC GS s T</li> </ul> <p>When run in real-time when this command is received</p> <p>This command is ignored with there is no audio playback.</p>					

### ESC GS s R z n1 n2 n3 d1 ... dn

Name	Playback received audio												
Code	ASCII	ESC	GS	s	R	z	n1	n2	n3	d1	...	dn	
	Hex.	1B	1D	73	52	z	n1	n2	n3	d1	...	dn	
	Decimal	27	29	115	82	z	n1	n2	n3	d1	...	dn	
Defined Region	<p>Z = 0</p> $1 \leq (n = n1 + n2 \times 256 + n3 \times 65536) \leq 16,777,215$ $0 \leq d \leq 255$												
Initial Value	---												
Function	<p>Does not register audio data in the non-volatile memory and plays back one time while receiving data.</p> <p>(k1 + k2 x 256 + k3 x 65536) specifies the number of bytes of the audio data.</p> <p>d is audio data in sampling frequency of 11.025 kHz, ADPCM format in quantization bit rate of 4 bits.</p> <p>When data transfer from the host is slow (theoretical value: 44,100 bps or lower), playback is intermittent.</p>												

**ESC GS s l z e a n c1 c2 d1 d2 t1 t2 ... 0xFF**

Name	Register automatic audio setting information															
Code	ASCII	ESC	GS	s	l	z	e	a	n	c1	c2	d1	d2	t1	t2	... 0xFF
	Hex.	1B	1D	73	49	z	e	a	n	c1	c2	d1	d2	t1	t2	... FF
	Decimal	27	29	115	73	z	e	a	n	c1	c2	d1	d2	t1	t2	... 255

Defined Region

z = 0, 1

0 ≤ e ≤ 63 (0x3F)

a = 1, 49

0 ≤ n ≤ 255

0 ≤ c1 + c2 x 256 ≤ 65535

0 ≤ d1 + d2 x 256 ≤ 65535

0 ≤ t1 + t2 x 256 ≤ 65535

Initial Value

At the time of shipment: Set to automatic audio

e	Printer Internal Status	a	n	c1+ c2 x 256	d1 + d2 x 256	t1 + t2 x 256
0x00	Cutter error	0	1	1	0	0
0x01	Flash ROM error	0	2	1	0	0
0x02	EE-PROM error	0	3	1	0	0
0x03	SRAM error	0	4	1	0	0
0x04	Head temperature detection error	0	5	1	0	0
0x05	Power voltage error	0	6	1	0	0
0x06 to 0x0F	(Reserved)	0	0	0	0	0
0x10	BM Error	0	7	1	0	0
0x11	PE error	0	8	1	0	0
0x12	Cover open	0	9	1	5	0
0x13	NE error	0	10	1	0	0
0x14 to 0x1F	(Reserved)	0	0	0	0	0
0x20	Head high temperature stop error	0	11	1	0	0
0x21 to 0x2F	(Reserved)	0	0	0	0	0
0x30	Idling	0	0	0	0	0
0x31 to 0x3F	(Reserved)	0	0	0	0	0

Function

When z = 1, the automatic audio setting information returns to the default factory setting. (At this time, do not send parameters after e.)

When z = 0, register the automatic audio setting information to playback when the printer's internal status occurs.

e specifies the printer's internal status assigned to audio.

a specifies the area where the audio data to set is stored.

a	Audio data storage area
1, 49	User area

n specifies the audio number to playback.

However, when n = 0, or audio data of a specified number is not registered, automatic audio is invalid.

(c1 + c2 x 256) specifies the number of times.

Delay time is the time from the occurrence of the printer's internal status to the start of audio playback (in seconds).

$(t1 + t2 \times 256)$  specifies the interval time.

Interval time is the time from the end of the previous audio to the start of the next audio (in seconds).

You can register multiple times by repeating parameters e to t2.

Perform lump registration until 0xFF which is the end code.

When the parameter is determined to be free of error, the printer starts processing this command.

When the parameter has an invalid value, there is no setting. (Sets already determined to be free of problems are valid.)

This command should be specified at the top of the line. However, if there is unprinted data in the line buffer, this command is executed after printing that data.

After registering automatic audio setting information, reset the printer.

Error processing mechanical operations or status processing and the like are not possible while registering automatic audio setting information (the time from receiving 0xFF which is the end code until printer reset is completed after automatic audio registration ends).

Audio will stop by inputting the FEED switch while there is audio playback using this setting.

## Command Transmission Example

Cutter error ••• User area 12<sup>th</sup>/3 times/delay 2 seconds/interval 1 second,

Flash ROM error ••• User area 13<sup>th</sup>/4 times/delay 5 seconds/interval 6 seconds

ESC GS s l ze a n c1 c2 d1 d2 t1 t2

1B 1D 73 49 00 00 01 0C 03 00 02 00 01 00

01 01 0D 04 00 05 00 06 00 FF

## ESC GS s U z n [k1 k2 k3 d1 ... dk]1 ... [k1 k2 k3 d1 ... dk]n

Name Register user area NV audio data

Code ASCII ESC GS s U z n [k1 k2 k3 d1 ... dk]1 ... [k1 k2 k3 d1 ... dk]n  
 Hex. 1B 1D 73 55 z n [k1 k2 k3 d1 ... dk]1 ... [k1 k2 k3 d1 ... dk]n  
 Decimal 27 29 115 85 z n [k1 k2 k3 d1 ... dk]1 ... [k1 k2 k3 d1 ... dk]n

Defined Region Z = 0  
 $0 \leq n \leq 255$   
 $0 \leq [k1 + k2 \times 256 + k3 \times 65536] 1 + \dots + [k1 + k2 \times 256 + k3 \times 65536] n \leq 1701888$   
 $0 \leq d \leq 255$

Initial Value English (See table below)

n	English Audio
1	Welcome !
2	Thank you !
3	Order coming in.
4	Drink Order coming in.
5	Food Order coming in.
6	Order has been Cancelled.
7	New order coming in.
8	Order to go coming in.
9	Print finished.
10	Please take your receipt.
11	Please come again.
12	Please give your receipt to the operator.
13	Now printing, please wait a moment.
14	Please do not pull the paper until printing finishes.
15	Thank you for visiting.
16	Please take the number ticket.
17	Please have a seat and wait a moment.
18	Thank you for your purchase.
19	Please wait here, we will guide you shortly.

Function All data already registered in the user area is erased when starting processing of this command.

Registers n audio data to the user area. (However, when n = 0, nothing is registered.)

Audio numbers are set in ascending order in the order they are registered from user area audio number 1 to n.

(k1 + k2 x 256 + k3 x 65536) specifies the number of bytes of the audio data.

d is audio data in sampling frequency of 11.025 kHz, monoaural ADPCM format in quantization bit rate of 4 bits.

The size of the registration region is 1,662 KB (approx. 308 seconds).

This command should be specified at the top of the line. However, if there is unprinted data in the line buffer, this command is executed after printing that data.

When the first parameter is determined to be free of error, the printer starts processing this command.

If the defined area specified by the parameter is not empty, or if there is an error in the parameter specification, register processing is aborted.

(The pre-registered and complete data is effective.)

The printer should be reset if audio data registration is completed or register processing is forcibly aborted.

Error processing, mechanical operations and status processing and the like cannot be executed while registering audio data (the time from when the first parameter is determined to be OK until printer initialization is completed after registering audio data).

## ESC GS s T a t1 t2

Name	Batch Playback NV Audio						
Code	ASCII	ESC	GS	s	T	t1	t2
	Hex.	1B	1D	73	54	t1	t2
	Decimal	27	29	115	84	t1	t2

Defined Region a = 1, 49  
 $0 \leq t1 + t2 \times 256 \leq 65535$

Initial Value ---

Function Lump-playback of NV audio registered in the non-volatile memory from #1 in ascending order.  
 a specifies the audio data registration area.

a	Audio data storage area
1, 49	User area

$(t1 + t2 \times 256)$  specifies how many seconds from the top to playback each audio data.

However, when  $(t1 + t2 \times 256) = 0$ , plays back each audio data completely without specifying the number of seconds.

Insert 1 second of interval time between the previous audio and the next audio.

Audio will stop by inputting the FEED switch while this command is running.

Audio will stop using the NV audio stop command (ESC GS s P) while running this command.

## 4-3-17 Star Original Hold print control Commands

### ESC SYN DC3 n

Name	Hold print control settings				
Code	ASCII	ESC	SYN	DC3	n
	Hex.	1B	16	13	n
	Decimal	27	22	19	n

Defined Region n = 0, 1, 48, 49, 255

Initial Value Memory S/W setting

Function Hold print control settings

n	Hold print control
0, 48	Invalid
1, 49	Valid
255	Memory switch setting

When this is set to enabled, check that there is no paper in the hold print sensor, and then execute printing.

If there is paper in the hold print sensor, the next printing is put on hold until the paper is removed.

The hold time can be set with the memory switches, and it is possible to select automatic cancel when

timeout occurs.

When this is set to disabled and printing is performed regardless of the paper hold sensor status.

Set to disabled when performing continuous printing.

If unprinted data exists in the image buffer at the time this command is processed, the data is printed out first

and then the command is executed.

However when in page mode, printing is not executed even if unprinted data exists in the image buffer.

If printing is in progress at the time this command is processed, the printer waits for printing to stop, and then

executes this command.

This command setting will not be initialized by the ESC @, CAN commands.

The setting by this command will be initialized by a printer reset.



## ESC SYN DC4 n

Name	Hold print status control settings				
Code	ASCII	ESC	SYN	DC4	n
	Hex.	1B	16	14	n
	Decimal	27	22	20	n

Defined Region n = 0, 1, 48, 49, 255

Initial Value Memory S/W setting

Function Hold print status control settings

n	Hold print status control
0, 48	Invalid
1, 49	Valid
255	Memory switch setting

When this is set to enabled, it is possible to use the hold print status.

If paper is in the hold print sensor, the hold print status is "paper present".

The hold time can be set with the memory switches, and it is possible to select automatic cancel of the "paper present" status when timeout occurs.

When this is set to disabled, the hold print status is fixed at "no paper".

For information about the hold print status, refer to Appendix 2 "Status Specifications".

In line mode, if unprinted data exists in the image buffer, the data is printed out first and then this command is executed.

However printing is not executed in page mode.

If printing is in progress at the time this command is processed, the printer waits for printing to stop, and then executes this command.

This command setting will not be initialized by the ESC @, CAN commands.

The setting by this command will be initialized by a printer reset.

### ESC GS ) s pL pH fn m (fn = 48)

Name Send paper hold sensor installation data.

Code ASCII ESC SYN DC4 n  
 Hex. 1B 16 14 n  
 Decimal 27 22 20 n

Defined Region pL = 2, pH = 0  
 fn = 48  
 m = 1

Function Hold print sensor installation data is sent in the format below.

<ESC> <GS> “)” “s” pL pH fn m n <NUL>

n	installation data
0	Not installed
1	Installed

When outside the parameter definitions or out of the specified sensor installation specifications, <ESC> <GS> “)” “s” <0> <0> fn <LF> <NUL> is returned.

If unprinted data exists in the image buffer at the time this command is processed, the command is executed without executing printing first.

## 5. CHARACTER CODE TABLE

Refer to the separate "Character Code Tables".

## 6. APPENDIX

### 6-1 Appendix 1 Cautions

<Precautions relating to printing and paper feeds>

(1) This is a line printer. Printing is always accompanied by a paper feed. Therefore, if a value that is smaller than the print data is set for one line of a line feed, paper will be fed more than the set amount to print that data.

For example, if one line feed is set to 10 dots (10/180 inches), a paper feed of only 10 dots will occur, but if printing a bit image, paper will be fed 24 dots.

Paper Feed Amount

		Necessary Paper Feed Amount (Dots)
Standard Characters	Font A	24 x Vertical Direction Magnification
	Font B	24 x Vertical Direction Magnification
	Chinese Character Fonts	24 x Vertical Direction Magnification
Rotated Character	Font A	12 x Vertical Direction Magnification
	Font B	9 x Vertical Direction Magnification
	Chinese Character Fonts	24 x Vertical Direction Magnification
Bit Image (ESC *)		24

(2) When the printer enters a data wait state for data from the host, printing and a paper feed is temporarily stopped, but when starting printing with data input, the paper feed can occur between 1 to 3 dots when starting printing. This particularly affects printing of bit images.

(3) The auto-cutter is recommended to after printing more than ten lines or after a paper feed. (If the cut paper is too small, it may not be easy to discharge, or can cause a paper jam.)

## 6-2 Appendix 2 Status Specifications

### 6-2-1 Identifying Transmission Status

The status of commands is identifiable because those transmitted by this printer use a dedicated but value. However, if using ASB, the three bytes after confirming the first ASB byte, excluding XOFF, are processed as ASB data. Without this, it is not possible to identify statuses such as GS r (Send status) and statuses after the second byte of an ASB.

#### Identification of Transmission Status

Command/Functions	Status							
	Bit7	Bit6	Bit5	Bit4	Bit3	Bit2	Bit1	Bit0
GS I	0	*	*	0	*	*	*	*
GS r	0	*	*	0	*	*	*	*
X ON	0	0	0	1	0	0	0	1
X OFF	0	0	0	1	0	0	1	1
DLE EOT	0	*	*	1	*	*	1	0
ASB (1th Byte)	0	*	*	1	*	*	0	0
ASB (2th to 4th Byte)	0	*	*	0	*	*	*	*

### 6-2-2 Error Details Per Model

Error		TSP600	TSP700	TSP800	TSP900	TUP1000	TSP700II	TSP650	TSP500	TSP800II	FVP10	BSC10	TSP043	TSP650II	TSP650II SK
Recoverable Error	Cover Open Error	○	○	○	○	○	○	○	○	○	○	○	○	○	○
	Paper out error	○	○	○	○	○	○	○	○	○	○	○	○	○	○
	Near-end error	○	○	○	○	○	○	○	○	○	○	○	○	○	×
Auto-recovery Error	Heat high temperature error	○	○	○	○	○	○	○	○	○	○	○	○	○	○
	Auto-cutter error	○	×	×	×	×	×	×	×	×	×	×	×	×	×
Non-recoverable Error	Power voltage error	○	○	○	○	○	○	○	○	○	○	○	○	○	○
	Thermistor error	○	○	○	○	○	○	○	○	○	○	○	○	○	○
	SRAM error	○	○	○	○	○	○	○	○	○	○	○	○	○	○
	FLASH error	○	○	○	○	○	○	○	○	○	○	○	○	○	○
	EEPROM error	×	×	○	○	○	○	○	○	○	○	○	×	○	×
	Auto-cutter error	×	○	○	○	○	○	○	○	○	○	○	○	○	○
Paper jam at presenter	×	×	×	○	×	×	×	○	×	×	×	×	×	×	

### 6-2-3 DLE EOT Status

#### 1. Printer Status (n=1)

	Contents	Status		Compatibility Per Model													
		"0"	"1"	TSP600	TSP700	TSP800	TUP900	TSP1000	TSP700II	TSP650	TSP500	TSP800II	FVP10	BSC10	TSP043	TSP650II	TSP650IISK
7	Fixed at "0"			-	-	-	-	-	-	-	-	-	-	-	-	-	-
6	Undefined ("0")			-	-	-	-	-	-	-	-	-	-	-	-	-	-
5	Undefined ("0")			-	-	-	-	-	-	-	-	-	-	-	-	-	-
4	Fixed at "1"			-	-	-	-	-	-	-	-	-	-	-	-	-	-
3	ON LINE/OFFLINE Status	ONLINE	OFFLINE	o	o	o	o	o	o	o	o	o	o	o	o	o	o
2	Drawer kick connector pin #3	"L"	"H"	o	o	o	x	x	o	o	o	o	o	o	o	o	o
	Presenter Cover	Closed	Open	x	x	x	x	x	x	x	x	x	x	x	x	x	x
1	Fixed at "1"			-	-	-	-	-	-	-	-	-	-	-	-	-	-
0	Fixed at "0"			-	-	-	-	-	-	-	-	-	-	-	-	-	-

Bit-2: Drawer kick connector #3 pin status is allocated for models not equipped with a presenter; presenter cover status is allocated to those models equipped with a presenter. TUP900 is provided with a presenter, but this bit is invalid because it does not have a presenter cover.

#### 2. Offline Cause Status (n=2)

Bit	Contents	Status		Compatibility Per Model													
		"0"	"1"	TSP600	TSP700	TSP800	TUP900	TSP1000	TSP700II	TSP650	TUP500	TSP800II	FVP10	BSC10	TSP043	TSP650II	TSP650IISK
7	Fixed at "0"			-	-	-	-	-	-	-	-	-	-	-	-	-	-
6	Error	No error	Error	o	o	o	o	o	o	o	o	o	o	o	o	o	o
5	Printing stops because of paper out	None	Print stopped	o	o	o	o	o	o	o	o	o	o	o	o	o	o
4	Fixed at "1"			-	-	-	-	-	-	-	-	-	-	-	-	-	-
3	Paper SW input	No SW Input	SW Input	o	o	o	o	o	o	o	o	o	o	o	o	o	o
2	Cover Status	Closed	Open	o	o	o	o	o	o	o	o	o	o	o	o	o	o
1	Fixed at "1"			-	-	-	-	-	-	-	-	-	-	-	-	-	-
0	Fixed at "0"			-	-	-	-	-	-	-	-	-	-	-	-	-	-

Bit-6: Indicates this error is non-recoverable.

Bit-5: Bit-5 = "1" (Print stopped) when printing stops because there is no paper.

TSP600/TSP700/TSP800

When the printer is Busy in the Paper-end state and there is data in the receive buffer, this bit is set. While processing this command, this command is included in the receive buffer.

### 3. Error Cause Status (n=3)

Bit	Contents	Status		Compatibility Per Model													
		"0"	"1"	TSP600	TSP700	TSP800	TUP900	TSP1000	TSP700II	TSP650	TUP500	TSP800II	FVP10	BSC10	TSP043	TSP650II	TSP650IISK
7	Fixed at "0"			-	-	-	-	-	-	-	-	-	-	-	-	-	-
6	Auto-recovery Error	No error	Error	o	o	o	o	o	o	o	o	o	o	o	o	o	o
5	Non-recoverable Error	No error	Error	o	o	o	o	o	o	o	o	o	o	o	o	o	o
4	Fixed at "1"			-	-	-	-	-	-	-	-	-	-	-	-	-	-
3	Auto-cutter error	No error	Error	o	o	o	o	o	o	o	o	o	o	o	o	o	o
2	Black mark error	No error	Error	o	o	o	X	o	o	X	X	o	o	o	o	x	x
	Mechanical Error	No error	Error	X	X	X	o	X	X	X	o	X	X	X	X	x	x
1	Fixed at "1"			-	-	-	-	-	-	-	-	-	-	-	-	-	-
0	Fixed at "0"			-	-	-	-	-	-	-	-	-	-	-	-	-	-

Bit-2: Black mark error status is allocated for models not equipped with a presenter; mechanical error status is allocated to those models equipped with a presenter. Black mark error status is set only when the black mark is enabled.

A mechanical error on models provided with a presenter represents a paper jam in the presenter and black mark errors.

### 4. Continuous Paper Detector Status (n=4)

Bit	Contents	Status		Compatibility Per Model													
		"0"	"1"	TSP600	TSP700	TSP800	TUP900	TSP1000	TSP700II	TSP650	TUP500	TSP800II	FVP10	BSC10	TSP043	TSP650II	TSP650IISK
7	Fixed at "0"			-	-	-	-	-	-	-	-	-	-	-	-	-	-
6	Paper out sensor	Has paper	Paper Out	o	o	o	o	o	o	o	o	o	o	o	o	o	o
5	Paper out sensor	Has paper	Paper Out	o	o	o	o	o	o	o	o	o	o	o	o	o	o
4	Fixed at "1"			-	-	-	-	-	-	-	-	-	-	-	-	-	-
3	Near-end Sensor	Has paper	Paper Out	o	o	o	o	o	o	o	o	o	o	o	o	o	X
2	Near-end Sensor	Has paper	Paper Out	o	o	o	o	o	o	o	o	o	o	o	o	o	X
	Black mark sensor status	White detection	Black detection	o	o	o	X	X	o	-	X	o	X	X	X	-	-
1	Fixed at "1"			-	-	-	-	-	-	-	-	-	-	-	-	-	-
0	Fixed at "0"			-	-	-	-	-	-	-	-	-	-	-	-	-	-

Bit-2: This bit functions as the status indicating the near end sensor when the black mark is disabled. When using the black mark, it functions as the status to indicate the black mark sensor status.

However, on TUP900/TSP1000/TUP500/FVP10, it functions as the status to indicate the near end sensor even when using black marks.

## 5. Presenter Paper Detector Status (n =5)

Bit	Contents	Status		Compatibility Per Model													
		"0"	"1"	TSP600	TSP700	TSP800	TUP900	TSP1000	TSP700II	TSP650	TUP500	TSP800II	FVP10	BSC10	TSP043	TSP650II	TSP650IISK
7	Fixed at "0"			-	-	-	-	-	-	-	-	-	-	-	-	-	-
6	Undefined ("0")			-	-	-	-	-	-	-	-	-	-	-	-	-	-
5	Undefined ("0")			-	-	-	-	-	-	-	-	-	-	-	-	-	-
4	Fixed at "1"			-	-	-	-	-	-	-	-	-	-	-	-	-	-
3	Presenter paper status	Has paper	Paper Out (Recovered)	X	X	X	○	X	X	X	○	X	X	X	X	X	X
	Hold print status control	Paper Ou	Has paper	X	X	X	X	X	X	X	X	X	X	X	X	X	○
2	Undefined ("0")			-	-	-	-	-	-	-	-	-	-	-	-	-	-
1	Fixed at "1"			-	-	-	-	-	-	-	-	-	-	-	-	-	-
0	Fixed at "0"			-	-	-	-	-	-	-	-	-	-	-	-	-	-



## 6-2-4 ASB Status Specifications

This ASB status applies to the following I/F. The STAR mode ASB status is sent with a USB I/F. (Refer to the “STAR Line Mode Command Specifications Manual” for details regarding the STAR mode ASB status.)

- USB

With the USB I/F on the models below, Star Mode ASB status is sent.

(See the Star Line Mode Command Specifications for details on the Star Mode ASB status.)

TSP600/TSP700/TSP800/TUP900/TSP1000/TSP700II Ver. 1.0 to 1.4/TSP650 Ver. 1.0 to 1.4/

TUP500 Ver. 1.0

- RS-232C

- Parallel

- Ethernet (See section 6-2-5 Printer Status Transmission Specification When Using Ethernet and Wireless I/F for details.)

- Wireless LAN (See section 6-2-5 Printer Status Transmission Specification When Using Ethernet and Wireless I/F for details.)

- Bluetooth

### 1. First Byte (Printer Information)

Bit	Contents	Status		Targeted Status n					Compatibility Per Model														
		"0"	"1"	Bit7	Bit3	Bit2	Bit1	Bit0	TSP600	TSP700	TSP800	TUP900	TSP1000	TSP700II	TSP650	TUP500	TSP800II	FVP10	BSC10	TSP043	TSP650II	TSP650IISK	
7	Fixed at "0"								-	-	-	-	-	-	-	-	-	-	-	-	-	-	-
6	Paper SW input	No SW Input	SW Input				○		○	○	○	○	○	○	○	○	○	○	○	○	○	○	○
5	Cover Status	Closed	Open				○		○	○	○	○	○	○	○	○	○	○	○	○	○	○	○
4	Fixed at "1"								-	-	-	-	-	-	-	-	-	-	-	-	-	-	-
3	ONLINE/OFFLINE Status	ONLINE	OFFLINE				○		○	○	○	○	○	○	○	○	○	○	○	○	○	○	○
2	Drawer kick connector pin #3	"L"	"H"					○	○	○	○	X	X	○	○	X	○	○	○	○	○	○	○
	Presenter Cover	Closed	Open				○		X	X	X	X	X	X	X	X	X	X	X	X	X	X	X
1	Undefined ("0")								-	-	-	-	-	-	-	-	-	-	-	-	-	-	-
0	Undefined ("0")								-	-	-	-	-	-	-	-	-	-	-	-	-	-	-

Bit-2: Drawer kick connector #3 pin status is allocated for models not equipped with a presenter; presenter cover status is allocated to those models equipped with a presenter. TUP900 and TUP500 are provided with a presenter, but this bit is invalid because it does not have a presenter cover.

## 2. Second Byte (Error Information)

Bit	Contents	Status		Targeted Status n					Compatibility Per Model														
		"0"	"1"	Bit7	Bit3	Bit2	Bit1	Bit0	TSP600	TSP700	TSP800	TUP900	TSP1000	TSP700II	TSP650	TUP500	TSP800II	FVP10	BSC10	TSP043	TSP650II	TSP650II SK	
7	Fixed at "0"								-	-	-	-	-	-	-	-	-	-	-	-	-	-	-
6	Auto-recovery Error	No error	Error			o			o	o	o	o	o	o	o	o	o	o	o	o	o	o	o
5	Non-recoverable Error	No error	Error			o			o	o	o	o	o	o	o	o	o	o	o	o	o	o	o
4	Fixed at "0"								-	-	-	-	-	-	-	-	-	-	-	-	-	-	-
3	Auto-cutter Error	No error	Error			o			o	o	o	o	o	o	o	o	o	o	o	o	o	o	o
2	Black mark error	No error	Error	o					o	o	o	x	o	o	x	x	o	o	o	o	x	x	
	Mechanical Error	No error	Error			o			x	x	x	o	x	x	x	o	x	x	x	x	x	x	
1	Paper SW input	No SW Input	SW Input				o		x	x	x	o	x	x	x	o	x	x	x	x	x	x	
0	Online recovery wait	No waiting for recovery	Wait for recovery				o		x	x	x	o	x	x	x	o	x	x	x	x	x	x	

Bit-2: Black mark error status is allocated for models not equipped with a presenter; mechanical error status is allocated to those models equipped with a presenter.

Black mark error status is set only when the black mark is enabled.

A TUP900/TUP500 mechanical error represents a paper jam in the presenter and black mark errors.

## 3. Third Byte (Paper Detector Information)

Bit	Contents	Status		Targeted Status n					Compatibility Per Model														
		"0"	"1"	Bit7	Bit3	Bit2	Bit1	Bit0	TSP600	TSP700	TSP800	TUP900	TSP1000	TSP700II	TSP650	TUP500	TSP800II	FVP10	BSC10	TSP043	TSP650II	TSP650II SK	
7	Fixed at "0"								-	-	-	-	-	-	-	-	-	-	-	-	-	-	-
6	Undefined ("0")								-	-	-	-	-	-	-	-	-	-	-	-	-	-	-
5	Undefined ("0")								-	-	-	-	-	-	-	-	-	-	-	-	-	-	-
4	Fixed at "0"								-	-	-	-	-	-	-	-	-	-	-	-	-	-	-
3	Paper out sensor	Has paper	Paper Out		o				o	o	o	o	o	o	o	o	o	o	o	o	o	o	o
2	Paper out sensor	Has paper	Paper Out		o				o	o	o	o	o	o	o	o	o	o	o	o	o	o	o
1	Near-end Sensor	Has paper	Paper Out		o				o	o	o	o	o	o	o	o	o	o	o	o	o	o	x
0	Near-end Sensor	Has paper	Paper Out		o				o	o	o	o	o	o	o	o	o	o	o	o	o	o	x

#### 4. Fourth Byte (Paper Detector Information)

Bit	Contents	Status		Targeted Status n					Compatibility Per Model																
		"0"	"1"	Bit7	Bit3	Bit2	Bit1	Bit0	TSP600	TSP700	TSP800	TUP900	TSP1000	TSP700II	TSP650	TUP500	TSP800II	FVP10	BSC10	TSP043	TSP650II	TSP650II SK			
7	Fixed at "0"								-	-	-	-	-	-	-	-	-	-	-	-	-	-	-		
6	Black mark sensor status	White detection	Black detection	o					o	o	o	x	x	x	x	x	x	x	x	x	x	x	x		
5	Undefined ("0")								-	-	-	-	-	-	-	-	-	-	-	-	-	-	-		
4	Fixed at "0"								-	-	-	-	-	-	-	-	-	-	-	-	-	-	-		
3	Undefined ("0")								-	-	-	-	-	-	-	-	-	-	Fixed at "1"	Fixed at "1"	-	-	-		
2	Undefined ("0")								-	-	-	-	-	-	-	-	-	-	Fixed at "1"	Fixed at "1"	-	-	-		
1	Presenter paper status	Has paper	Paper Out (Recovered)		o				x	x	x	o	x	x	x	o	x	x	Fixed at "1"	Fixed at "1"	x	x	-		
	Stack sensor paper status	Has paper	Paper Out		o				x	x	x	x	o	x	x	x	x	x					x	x	-
	Hold print status control	Paper Out	Has paper		o				x	x	x	x	x	x	x	x	x	x					x	o	-
0	Undefined ("0")								-	-	-	-	-	-	-	-	-	-	Fixed at "1"	Fixed at "1"	-	-	-		

Bit-6: This bit is set only when black marks are effective.

## 6-2-5 Printer Status Transmission Specification When Using Ethernet and Wireless I/F

With a wireless LAN I/F, the printer status sending specifications are Star Original Expanded Status Specifications (\*2).

See the table below for printer status sending specifications for Ethernet I/F.

(1) Spec.	Printer Status Sending Specifications Star Original Expanded ASB Specifications (*2)	Automatic Status Sending Destination Specifications Distributes to All Hosts Connected to the Communication Port
--------------	---	---

	Ethernet I/F Used	Printer Status Sending Specifications	Automatic Status Sending Destination Specifications
(2) Spec.	IFBD-HE05/06 F/W Version (Main) Ver. 1.0.1	Star Original Expanded Status Specifications (*2)	Distributes to All Hosts Connected to the Communication Port
	IFBD-HE05/06 F/W Version (Main) Ver. 1.1.0	ESC/POS Standard Status Compatibility Specifications (*1)	Sends Only to Host for Print Session

(\*1) ESC/POS Standard Status Compatibility Specifications

In the same way as serial, parallel and USB, ASB is standard 4 bytes for ESC/POS, and the status using ESC/POS inquiry commands (DLE EOT, GS r, GS l, ESC v, ESC u etc.) is 1 byte for ESC/POS.

NSB function is fixed at invalid (does not send automatic status to the connected host), and ASB function can be set to valid/invalid.

(\*2) Star Original Expanded Status Specifications

The following describes the Star Original Expanded Status Specifications.

With these specifications, ESC/POS standard status (ASB or other statuses) are sent embedded in expanded status data attached to Star ASB.

See the STAR Line Mode Command Specifications for details on STAR ASB specifications.

NSB function is fixed at valid (sends automatic status to the connected host), and ASB function is fixed at valid.

The following will describe printer status transmission specifications for using an Ethernet interface and a wireless LAN interface.

See the Star Line Mode Command Specifications for details on Star's ASB specifications.

### 1) Transmission Format

- For transmitting only STAR ASB

STAR ASB (Second Byte Bit 7 = 1) + Length (Length = 0x0000)

- For transmitting printer status other than STAR ASB

STAR ASB (Second Byte Bit 7 = 1) + Length + Status Data

<Length Details>

- 2 byte value indicating status data byte count ( $0x0000 \leq \text{Length} \leq 0x0200$ )
- When the status data is 10 bytes: Length = 0x000a
- Apply Length = 0x0000 to only transmit STAR ASB.
- When STAR ASB Second Byte B-7 is applied with Length, set to Bit-7 = 1

Status analysis detects the total byte count of ASB using the first byte of STAR ASB, and detects whether Length is appended using the second byte bit-7 of STAR ASB. It is also possible to analyze the status by getting the byte count of subsequent byte counts.

2) Status Data Transmission Format

Status type + Separator character 1 + Data type + Status length + *Printer status* + Separator character 2

## 1. Status Type (2byte or 4Byte)

## • First and Second Bytes

Indicate the cause to generate a printer status.

- "00" Reserved
- "01" to "09" Reserved
- "10" to "49" Status Original Status Request Command
- "50" ESC/POS ASB
- "51" to "59" ESC/POS Real-time Status Request Command
- "60" to "A0" ESC/POS Status Request Command
- "A1" ESC/POS [Header to NUL ] Block Status Request Command
- "A2" to "FF" Reserved

## • Third and Fourth Bytes

When a cause occurs, these indicate the command n parameter.

If there is no n parameter, the third and fourth bytes can be omitted.

<Ex.> When n = 0x31 using the ESC SYN 3 n command, the third and fourth bytes are "31."

## 2 Separator character 1 (1 byte)

Sends ":"

## 3 Data Type (1byte)

Indicates printer status data; sends "B" (binary type).

## 4 Status Length (2 bytes)

2 byte value indicating printer status byte count.

## 5 Printer Status (Variable length)

Status sent by printer.

Status differs according to the cause.

See the command causes and automatic status for details on the content of statuses.

## 6 Separator character 2 (1 byte)

Sends ";

## 3) Status Transmission Specifications List

Status Cause	STAR ASB	Length	Status Data						
			Status Type		Separated	Data	Status	Printer	Separated
			First/Second Bytes Cause	Third/Fourth Bytes n Parameter	Character 1	Type	Length	Status	Character 2
ESC/POS ASB Automatic Status*1	STAR ASB	0x000B	"50"	Omitted	“.”	“B”	0x0004	Status	“.” “,”
DLE EOT n Printer Status Request	STAR ASB	0x000A	"51"	"01"≤n≤"05"	“.”	“B”	0x0001	Status	“.” “,”
GS I n Printer ID Request	STAR ASB	0x000A	"61"	"01"≤n≤"03" "31"≤n≤"33"	“.”	“B”	0x0001	Status	“.” “,”
GS r n Printer Status Request	STAR ASB	0x0008	"62"	"01"≤n≤"02" "31"≤n≤"32"	“.”	“B”	0x0001	Status	“.” “,”
ESC SYN 3 n Presenter Counter Request	STAR ASB	0x0011	"13"	"00"≤n≤"01" "30"≤n≤"31"	“.”	“B”	0x0008	Status	“.” “,”
ESC GS x I Request PDF417 Information	ASB	0x000C	"16"	Omitted	“.”	“B”	0x0005	Status	“.” “,”
ESC GS y I Request QR Code Information	ASB	0x000D	"19"	Omitted	“.”	“B”	0x0006	Status	“.” “,”
ESC GS ETX n1 n2 Print end counter request	ASB	0x000D	"20"	Omitted	“.”	“B”	0x0008	Status	“.” “,”
ESC u n Status request	ASB	0x000D	"A0"	"01"	“.”	“B”	0x0001	Status	“.” “,”
ESC v Status request	ASB	0x000D	"A0"	Omitted	“.”	“B”	0x0001	Status	“.” “,”
GS ( L / GS 8 L fn48, 51, 64 ESC GS ) L fn50 Command response request	ASB	Variable length	"A1"	Omitted	“.”	“B”	Variable length	Black Data	“.” “,”

\* The MSW region differs by model.

(\*1) ESC/POS automatic status is sent to all hosts connected to the TCP#9100 port.

### 6-3 Appendix-3 Blank Page Configuration

Blank code pages are code tables that are empty from character code 80H to FFH. They can be specified using the command below.

- ESC t n (n=255)
- ESC GS t n (n=255)

Also, it is possible to write data to the blank code page area using the command below.

- ESC GS = . . . . .

#### 1. Example configuration of Font-A data. (12 x 24 font)

	MSB				LSB					MSB				LSB			
d1									d2				0	0	0	0	
d3					.	.	.	.	d4				0	0	0	0	
d5			.	.	.	.	.	.	d6	.	.		0	0	0	0	
d7			.	.					d8	.	.		0	0	0	0	
d9	.	.							d10	.	.		0	0	0	0	
d11	.	.							d12	.	.		0	0	0	0	
d13	.	.							d14	.	.		0	0	0	0	
d15									d16	.	.		0	0	0	0	
d17									d18	.	.		0	0	0	0	
d19									d20	.	.		0	0	0	0	
d21								.	d22	.			0	0	0	0	
d23							.	.	d24				0	0	0	0	
d25							.	.	d26				0	0	0	0	
d27							.	.	d28				0	0	0	0	
d29					.	.	.		d30				0	0	0	0	
d31					.	.	.		d32				0	0	0	0	
d33					.	.			d34				0	0	0	0	
d35			.	.					d36				0	0	0	0	
d37	.	.	.						d38				0	0	0	0	
d39	.	.	.	.	.	.	.	.	d40	.	.	.	0	0	0	0	
d41	.	.	.	.	.	.	.	.	d42	.	.	.	0	0	0	0	
d43									d44				0	0	0	0	
d45									d46				0	0	0	0	
d47									d48				0	0	0	0	

## 2. Example configuration of Font-B data. (9 x 24 font)

	MSB						LSB							MSB						LSB															
d1													d2	0	0	0	0	0	0	0	0	0	0	0	0										
d3				•	•	•							d4	0	0	0	0	0	0	0	0	0	0	0	0										
d5			•	•	•	•							d6	0	0	0	0	0	0	0	0	0	0	0	0										
d7			•	•		•				•	•	•	d8	0	0	0	0	0	0	0	0	0	0	0	0										
d9	•	•									•	•	d10	0	0	0	0	0	0	0	0	0	0	0	0										
d11	•	•									•	•	d12	0	0	0	0	0	0	0	0	0	0	0	0										
d13	•	•									•	•	d14	0	0	0	0	0	0	0	0	0	0	0	0										
d15											•	•	d16	0	0	0	0	0	0	0	0	0	0	0	0										
d17											•	•	d18	0	0	0	0	0	0	0	0	0	0	0	0										
d19											•	•	d20	0	0	0	0	0	0	0	0	0	0	0	0										
d21											•	•	•	d22	0	0	0	0	0	0	0	0	0	0	0	0									
d23										•	•	•	•	d24	0	0	0	0	0	0	0	0	0	0	0	0									
d25										•	•	•	d26	0	0	0	0	0	0	0	0	0	0	0	0										
d27										•	•	•	d28	0	0	0	0	0	0	0	0	0	0	0	0										
d29										•	•	•	d30	0	0	0	0	0	0	0	0	0	0	0	0										
d31										•	•							d32	0	0	0	0	0	0	0	0	0	0	0	0					
d33										•	•							d34	0	0	0	0	0	0	0	0	0	0	0	0					
d35										•	•	•							d36	0	0	0	0	0	0	0	0	0	0	0	0				
d37										•	•	•							d38	0	0	0	0	0	0	0	0	0	0	0	0				
d39										•	•	•	•	•	•	•							d40	0	0	0	0	0	0	0	0	0	0	0	0
d41										•	•	•	•	•	•							d42	0	0	0	0	0	0	0	0	0	0	0	0	
d43																						d44	0	0	0	0	0	0	0	0	0	0	0	0	
d45																						d46	0	0	0	0	0	0	0	0	0	0	0	0	
d47																						d48	0	0	0	0	0	0	0	0	0	0	0	0	



## 6-4 Appendix 4 Standard Mode

EPSON has models that have 180 DPI and 203 DPI print heads. STAR's print head is 203 DPI. Therefore, when targeting models with the EPSON 180 DPI print head, it is necessary to correct the line spacing that will be caused by the difference in the head's print density. Correction is done using the memory switches (Print dot count: ESC/POS Compatible Mode/Max). Setting the memory switches to ESC/POS compatible mode artificially makes the number of dot counts the same as an EPSON printer. However, if the target model has a 203 DPI print head, correction is unnecessary so memory switches for print dot settings are not equipped.

### 6-4-1 Printing Region

#### 1. TSP600/TSP700

##### Print Region Initial Values

Print Region Setting (Memory Switch Setting)	Printing Dot Count Setting (Memory Switch Setting)	Initial Value		
		nL	nH	Print region
80mm	ESC/POS Compatible Mode	56	2	71mm
	Max.	128	2	80mm
72mm	ESC/POS Compatible Mode	0	2	64mm
	Max.	64	2	72mm
52.5mm	ESC/POS Compatible Mode	120	1	47mm
	Max.	164	1	52.5mm
50.8mm	ESC/POS Compatible Mode	104	1	45mm
	Max.	150	1	50.8mm

Basic calculated pitch initial value: X=1/180 (inch), Y=1/360 (inch)

#### 2 TSP800

##### Print Region Initial Values

Print Region Setting (Memory Switch Setting)	Initial Value		
	nL	nH	Print region
104mm	64	3	104mm

Basic calculated pitch initial value: X=1/180 (inch), Y=1/360 (inch)

#### 3 TUP900

##### Print Region Initial Values

Print Region Setting (Memory Switch Setting)	Initial Value		
	nL	nH	Print region
104mm	64	3	104mm
80mm	128	2	80mm
72mm	64	2	72mm
56mm	192	1	56mm

Basic calculated pitch initial value: X=1/203 (inch), Y=1/203 (inch)

## 4 TSP1000

## Print Region Initial Values

Print Region Setting (Memory Switch Setting)	Initial Value		
	nL	nH	Print region
80mm	128	2	80mm
72mm	64	2	72mm
55mm	184	1	55mm
52mm	160	1	52mm
47mm	120	1	47mm
42mm	80	1	42mm

Basic calculated pitch initial value: X=1/203 (inch), Y=1/203 (inch)

## 5 TSP700II

## Initial Value of Print Region

Print Region Setting (Memory Switch Setting)	Print Position Setting (Memory Switch Setting)	Initial Value		
		nL	nH	Print region
80mm	ESC/POS Compatible Mode	56	2	71mm
	Max.	128	2	80mm
72mm	ESC/POS Compatible Mode	0	2	64mm
	Max.	64	2	72mm
52.5mm	ESC/POS Compatible Mode	120	1	47mm
	Max.	164	1	52.5mm
50.8mm	ESC/POS Compatible Mode	104	1	45mm
	Max.	150	1	50.8mm
52mm	ESC/POS Compatible Mode	112	1	46mm
	Max.	160	1	52mm

Basic calculation pitch initial value: X=1/180(inch), Y=1/360(inch)

## 6 TSP650/BSC10/TSP043/TSP650II

## Initial Value of Print Region

Print Region Setting (Memory Switch Setting)	Print Position Setting (Memory Switch Setting)	Initial Value		
		nL	nH	Print region
72mm	ESC/POS Compatible Mode	0	2	64mm
	Max.	64	2	72mm
50.8mm	ESC/POS Compatible Mode	104	1	45mm
	Max.	150	1	50.8mm

Basic calculation pitch initial value: X=1/180(inch), Y=1/360(inch)

## 7 TUP500

## Initial value of the print region

Print Region Setting (Memory Switch Setting)	Initial Value		
	nL	nH	Print Region
80 mm	128	2	80 mm
72 mm	64	2	72 mm
52 mm	160	1	52 mm

Basic calculated pitch initial value: X = 1/203 (inches), Y = 1/203 (inches)

\* TUP500 can set the print region in 1 mm units.

## • TSP800II

Initial value of the print region

Printing Region Setting (Memory Switch Setting)	Initial Value		
	nL	nH	Left Margin
104mm	64	3	104mm
72mm	64	2	72mm

Basic Calculated Pitch Initial Value: X = 1/203 (inch), Y = 1/203 (inch)

## • FVP10

Initial value of the print region

Printing Region Setting (Memory Switch Setting)	Printing Position Setting (Memory Switch Setting)	Initial Value		
		nL	nH	Left Margin
72mm	ESC/POS Compatibility Mode	0	2	64mm
	Max.	64	2	72mm
52.5mm	ESC/POS Compatibility Mode	120	1	47mm
	Max.	164	1	52.5mm
50.8mm	ESC/POS Compatibility Mode	104	1	45mm
	Max.	150	1	50.8mm
52mm	ESC/POS Compatibility Mode	112	1	46mm
	Max.	160	1	52mm

Basic Calculated Pitch Initial Value: X = 1/180 (inch), Y = 1/360 (inch)

## • TSP650IISK

Initial value of the print region

Printing Region Setting (Memory Switch Setting)	Printing Position Setting (Memory Switch Setting)	Initial Value		
		nL	nH	Left Margin
72mm	ESC/POS Compatibility Mode	0	2	64mm
	Max.	64	2	72mm
50.8mm	ESC/POS Compatibility Mode	104	1	45mm
	Max.	150	1	50.8mm
34.5mm	Max.	20	1	34.5mm
32mm	Max.	0	1	32mm

Basic Calculated Pitch Initial Value: X = 1/180 (inch), Y = 1/360 (inch)

## 6-4-2 Left Margin

- TSP600/TSP700

### Left Margin Initial Value

Print Region Setting (Memory Switch Setting)	Printing Dot Count Setting (Memory Switch Setting)	Initial Value		
		nL	nH	Left Margin
80mm	ESC/POS Compatible Mode	40	0	5mm
	Max.	0	0	0mm
72mm	ESC/POS COMPATIBLE MODE	32	0	4mm
	Max.	0	0	0mm
52.5mm	ESC/POS COMPATIBLE MODE	24	0	3mm
	Max.	0	0	0mm
50.8mm	ESC/POS COMPATIBLE MODE	24	0	3mm
	Max.	0	0	0mm

Basic calculated pitch initial value: X=1/180 (inch), Y=1/360 (inch)

- TSP800

### Left Margin Initial Value

Print Region Setting (Memory Switch Setting)	Initial Value		
	nL	nH	Left Margin
104mm	0	0	0mm

Basic calculated pitch initial value: X=1/180 (inch), Y=1/360 (inch)

- TUP900

### Left Margin Initial Value

Print Region Setting (Memory Switch Setting)	Initial Value		
	nL	nH	Left Margin
104mm	0	0	0mm
80mm	0	0	0mm
72mm	0	0	0mm
56mm	0	0	0mm

Basic calculated pitch initial value: X=1/203 (inch), Y=1/203 (inch)

- TSP1000

### Left Margin Initial Values

Print Region Setting (Memory Switch Setting)	Initial Value		
	nL	nH	Left Margin
80mm	0	0	0mm
72mm	0	0	0mm
55mm	0	0	0mm
52mm	0	0	0mm
47mm	0	0	0mm
42mm	0	0	0mm

Basic calculated pitch initial value: X=1/203 (inch), Y=1/203 (inch)

## • TSP700II

## Left Margin Initial Value

Print Region Setting (Memory Switch Setting)	Printing Dot Count Setting (Memory Switch Setting)	Initial Value		
		nL	nH	Left Margin
80mm	ESC/POS Compatible Mode	40	0	5mm
	Max.	0	0	0mm
72mm	ESC/POS COMPATIBLE MODE	32	0	4mm
	Max.	0	0	0mm
52.5mm	ESC/POS COMPATIBLE MODE	24	0	3mm
	Max.	0	0	0mm
50.8mm	ESC/POS COMPATIBLE MODE	24	0	3mm
	Max.	0	0	0mm
52mm	ESC/POS COMPATIBLE MODE	24	0	3mm
	Max.	0	0	0mm

Basic calculated pitch initial value: X=1/180 (inch), Y=1/360 (inch)

## • TSP650/BSC10/TSP043/TSP650II

## Left Margin Initial Value

Print Region Setting (Memory Switch Setting)	Printing Dot Count Setting (Memory Switch Setting)	Initial Value		
		nL	nH	Left Margin
72mm	ESC/POS COMPATIBLE MODE	32	0	4mm
	Max.	0	0	0mm
50.8mm	ESC/POS COMPATIBLE MODE	24	0	3mm
	Max.	0	0	0mm

Basic calculated pitch initial value: X=1/180 (inch), Y=1/360 (inch)

## • TUP500

## Left Margin Initial Value

Print Region Setting (Memory Switch Setting)	Initial Value		
	nL	nH	Print Region
80 mm	0	0	0 mm
72 mm	0	0	0 mm
52 mm	0	0	0 mm

Basic calculated pitch initial value: X = 1/203 (inches), Y = 1/203 (inches)

\* TUP500 can set the print region in 1 mm units.

- TSP800II

## Left margin initial value

Printing Region Setting (Memory Switch Setting)	Initial Value		
	nL	nH	Left Margin
104mm	0	0	0mm
72mm	0	0	0mm

Basic Calculated Pitch Initial Value: X = 1/203 (inch), Y = 1/203 (inch)

- FVP10

## Left margin initial value

Printing Region Setting (Memory Switch Setting)	Printing Position Setting (Memory Switch Setting)	Initial Value		
		nL	nH	Left Margin
72mm	ESC/POS Compatibility Mode	32	0	4mm
	Max.	0	0	0mm
52.5mm	ESC/POS Compatibility Mode	24	0	3mm
	Max.	0	0	0mm
50.8mm	ESC/POS Compatibility Mode	24	0	3mm
	Max.	0	0	0mm
52mm	ESC/POS Compatibility Mode	24	0	3mm
	Max.	0	0	0mm

Basic Calculated Pitch Initial Value: X = 1/180 (inch), Y = 1/360 (inch)

- TSP650IISK

## Left margin initial value

Printing Region Setting (Memory Switch Setting)	Printing Position Setting (Memory Switch Setting)	Initial Value		
		nL	nH	Left Margin
72mm	ESC/POS Compatibility Mode	32	0	4mm
	Max.	0	0	0mm
52.5mm	ESC/POS Compatibility Mode	24	0	3mm
	Max.	0	0	0mm
50.8mm	ESC/POS Compatibility Mode	24	0	3mm
	Max.	0	0	0mm
52mm	ESC/POS Compatibility Mode	24	0	3mm
	Max.	0	0	0mm

Basic Calculated Pitch Initial Value: X = 1/180 (inch), Y = 1/360 (inch)

## 6-5 Appendix 5 Page Mode

### 6-5-1 Page Mode Print Region

EPSON has models that have 180 DPI and 203 DPI print heads. STAR's print head is 203 DPI. Therefore, when targeting models with the EPSON 180 DPI print head, it is necessary to correct the line spacing that will be caused by the difference in the head's print density. Correction is done using the memory switches (Print dot count: ESC/POS Compatible Mode/Max). Setting the memory switches to ESC/POS compatible mode artificially makes the number of dot counts the same as an EPSON printer. The page mode printing region initial value (= maximum value) changes according to the basic calculated pitch correction when the memory switch print dot count in page mode is set to ESC/POS Compatible mode. However, if the target model has a 203 DPI print head, correction is unnecessary so memory switches for print dot settings are not equipped.

The following illustrates the basic calculated pitch correction of the print region in page mode on TSP700.

<Basic calculated pitch correction conceptual view; TSP700; Print dots = ESC/POS compatible mode; Print region setting is 72 mm>

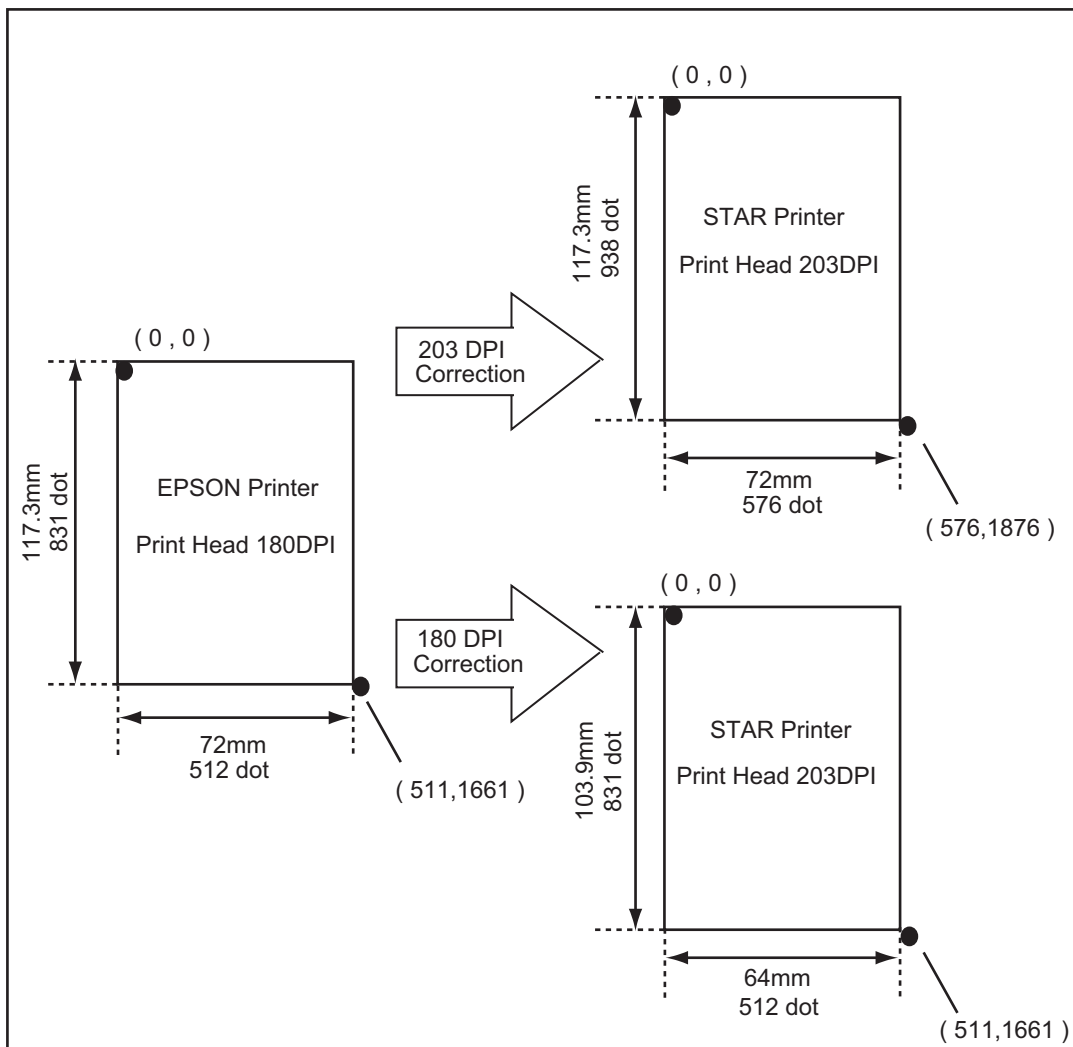

## • TSP600/TSP700

Page mode print region initial value (dxL, dxH, dyL, dyH) &lt;Print Dot count: ESC/POS compatible mode&gt;

Print region Setting (Memory Switch Setting)	Basic Calculated Pitch Correction (DIPSW Setting)	Initial Value (= Maximum Value)					
		dxL	dxH	dyL	dyH	Printable Region Width	
						X Dir.	Y Dir.
80mm	203DPI	128	2	84	7	80mm	117.3mm
	180DPI	56	2	126	6	71mm	103.9mm
72mm	203DPI	64	2	84	7	72mm	117.3mm
	180DPI	0	2	126	6	64mm	103.9mm
52.5mm	203DPI	164	1	84	7	52.5mm	117.3mm
	180DPI	120	1	126	6	47mm	103.9mm
50.8mm	203DPI	150	1	84	7	50.8mm	117.3mm
	180DPI	104	1	126	6	45mm	103.9mm

Basic calculated pitch initial value: X=1/180 (inch), Y=1/360 (inch)

Page mode print region initial value (dxL, dxH, dyL, dyH) &lt;Print Dot count: Maximum&gt;

Print region Setting (Memory Switch Setting)	Basic Calculated Pitch Correction (DIPSW Setting)	Initial Value (= Maximum Value)					
		dxL	dxH	dyL	dyH	Printable Region Width	
						X Dir.	Y Dir.
80mm	203/180 DPI	128	2	84	7	80mm	117.3mm
72mm	203/180 DPI	64	2	84	7	72mm	117.3mm
52.5mm	203/180 DPI	164	1	8	7	52.5mm	117.3mm
50.8mm	203/180 DPI	150	1	84	7	50.8mm	117.3mm

Basic calculated pitch initial value: X=1/180 (inch), Y=1/360 (inch)

## • TSP800

Page mode print region initial value (dxL, dxH, dyL, dyH)

Print region Setting (Memory Switch Setting)	Basic Calculated Pitch Correction (DIPSW Setting)	Initial Value (= Maximum Value)					
		dxL	dxH	dyL	dyH	Printable Region Width	
						X Dir.	Y Dir.
104mm	203/180 DPI	64	3	128	6	104mm	104mm

Basic calculated pitch initial value: X=1/180 (inch), Y=1/360 (inch)



## • TUP900

Page mode print region initial value (dxL, dxH, dyL, dyH)

Print region Setting (Memory Switch Setting)	Basic Calculated Pitch Correction (DIPSW Setting)	Initial Value (= Maximum Value)					
		dxL	dxH	dyL	dyH	Printable Region Width	
						X Dir.	Y Dir.
104mm	203/180 DPI	64	3	96	9	104mm	300mm
80mm	203/180 DPI	128	2	96	9	80mm	300mm
72mm	203/180 DPI	64	2	96	9	72mm	300mm
56mm	203/180 DPI	192	1	96	9	56mm	300mm

Basic calculated pitch initial value: X=1/203 (inch), Y=1/203 (inch)

## • TSP1000

Page mode print region initial value (dxL, dxH, dyL, dyH)

Print region Setting (Memory Switch Setting)	Basic Calculated Pitch Correction (DIPSW Setting)	Initial Value (= Maximum Value)					
		dxL	dxH	dyL	dyH	Printable Region Width	
						X Dir.	Y Dir.
80mm	--	128	2	96	9	80mm	300mm
72mm	--	64	2	96	9	72mm	300mm
55mm	--	184	1	96	9	55mm	300mm
52mm	--	160	1	96	9	52mm	300mm
47mm	--	120	1	96	9	47mm	300mm
42mm	--	80	1	96	9	42mm	300mm

Basic calculated pitch initial value: X=1/203 (inch), Y=1/203 (inch)

## • TSP700II

Page mode print region initial value (dxL, dxH, dyL, dyH) &lt;Print positions: ESC/POS compatible mode&gt;

Print region Setting (Memory Switch Setting)	Basic Calculated Pitch Correction (DIPSW Setting)	Initial Value (= Maximum Value)						Maximum Value	
		dxL	dxH	dyL	dyH	Printable Region Width		Printable Region Width	
						X Dir.	Y Dir.	X Dir.	Y Dir.
80mm	203DPI	128	2	84	7	80mm	117.3mm	80mm	300mm
	180DPI	56	2	126	6	71mm	103.9mm	80mm	300mm
72mm	203DPI	64	2	84	7	72mm	117.3mm	72mm	300mm
	180DPI	0	2	126	6	64mm	103.9mm	72mm	300mm
52.5mm	203DPI	164	1	84	7	52.5mm	117.3mm	52.5mm	300mm
	180DPI	120	1	126	6	47mm	103.9mm	52.5mm	300mm
50.8mm	203DPI	150	1	84	7	50.8mm	117.3mm	50.8mm	300mm
	180DPI	104	1	126	6	45mm	103.9mm	50.8mm	300mm
52mm	203DPI	160	1	84	7	52mm	117.3mm	52mm	300mm
	180DPI	112	1	126	6	46mm	103.9mm	52mm	300mm

Basic calculated pitch initial value: X=1/180 (inch), Y=1/360 (inch)

Page mode print region initial value (dxL, dxH, dyL, dyH) &lt;Print positions: Maximum&gt;

Print region Setting (Memory Switch Setting)	Basic Calculated Pitch Correction (DIPSW Setting)	Initial Value (= Maximum Value)						Maximum Value	
		dxL	dxH	dyL	dyH	Printable Region Width		Printable Region Width	
						X Dir.	Y Dir.	X Dir.	Y Dir.
80mm	203/180DPI	128	2	84	7	80mm	117.3mm	80mm	300mm
72mm	203/180DPI	64	2	84	7	72mm	117.3mm	72mm	300mm
52.5mm	203/180DPI	164	1	8	7	52.5mm	117.3mm	52.5mm	300mm
50.8mm	203/180DPI	150	1	84	7	50.8mm	117.3mm	50.8mm	300mm
52mm	203/180DPI	160	1	84	7	52mm	117.3mm	52mm	300mm

Basic calculated pitch initial value: X=1/180 (inch), Y=1/360 (inch)

## • TSP650/TSP650II

Page mode print region initial value (dxL, dxH, dyL, dyH) &lt;Print positions: ESC/POS compatible mode&gt;

Print region Setting (Memory Switch Setting)	Basic Calculated Pitch Correction (DIPSW Setting)	Initial Value (= Maximum Value)						Maximum Value	
		dxL	dxH	dyL	dyH	Printable Region Width		Printable Region Width	
						X Dir.	Y Dir.	X Dir.	Y Dir.
72mm	203DPI	64	2	84	7	72mm	117.3mm	72mm	250mm
	180DPI	0	2	126	6	64mm	103.9mm	64mm	250mm
50.8mm	203DPI	150	1	84	7	50.8mm	117.3mm	50.8mm	250mm
	180DPI	104	1	126	6	45mm	103.9mm	50.8mm	250mm

Basic calculated pitch initial value: X=1/180 (inch), Y=1/360 (inch)

Page mode print region initial value (dxL, dxH, dyL, dyH) &lt;Print positions: Maximum&gt;

Print region Setting (Memory Switch Setting)	Basic Calculated Pitch Correction (DIPSW Setting)	Initial Value (= Maximum Value)						Maximum Value	
		dxL	dxH	dyL	dyH	Printable Region Width		Printable Region Width	
						X Dir.	Y Dir.	X Dir.	Y Dir.
72mm	203/180DPI	64	2	84	7	72mm	117.3mm	72mm	250mm
50.8mm	203/180DPI	150	1	84	7	50.8mm	117.3mm	50.8mm	250mm

Basic calculated pitch initial value: X=1/180 (inch), Y=1/360 (inch)

## • TUP500

Page mode print region initial value (dxL, dxH, dyL, dyH)

Print region Setting (Memory Switch Setting)	Basic Calculated Pitch Correction (DIPSW Setting)	Initial Value (= Maximum Value)					
		dxL	dxH	dyL	dyH	Printable Region Width	
						X Dir.	Y Dir.
80 mm	--	128	2	96	9	80 mm	300 mm
72 mm	--	64	2	96	9	72 mm	300 mm
52 mm	--	160	1	96	9	52 mm	300 mm

Basic calculated pitch initial value: X=1/203 (inch), Y=1/203 (inch)

\* TUP500 can set the print region in 1 mm units.

## • TSP800II

Page mode print region initial value (dxL, dxH, dyL, dyH)

Printing Region Setting (Memory Switch Setting)	Basic Calculated Pitch Offset (Set by DIP switches)	Initial Value (= Max. Value)					
		dxL	dxH	dyL	dyH	Printable Region Width	
						X Dir.	Y Dir.
104mm	--	64	3	208	7	104mm	250mm
72mm	--	64	3	208	7	72mm	250mm

Basic Calculated Pitch Initial Value: X = 1/180 (inch), Y = 1/360 (inch)

## • FVP10

Page mode print region initial value (dxL, dxH, dyL, dyH) &lt;Print Dot Count: ESC/POS Compatibility Mode&gt;

Printing Region Setting (Memory Switch Setting)	Basic Calculated Pitch Offset (Set by DIP switches)	Initial Value				Maximum Value			
		dxL	dxH	dyL	dyH	Printable Region Width		Printable Region Width	
						X Direction	Y Direction	X Direction	Y Direction
72mm	203 DPI	64	2	84	7	72mm	117.3mm	72mm	300mm
	180 DPI	0	2	126	6	64mm	103.9mm	72mm	300mm
52.5mm	203 DPI	164	1	84	7	52.5mm	117.3mm	52.5mm	300mm
	180 DPI	120	1	126	6	47mm	103.9mm	52.5mm	300mm
50.8mm	203 DPI	150	1	84	7	50.8mm	117.3mm	50.8mm	300mm
	180 DPI	104	1	126	6	45mm	103.9mm	50.8mm	300mm
52mm	203DPI	160	1	84	7	52mm	117.3mm	52mm	300mm
	180DPI	112	1	126	6	46mm	103.9mm	52mm	300mm

Basic Calculated Pitch Initial Value: X = 1/180 (inch), Y = 1/360 (inch)

Page mode print region initial value (dxL, dxH, dyL, dyH) &lt;Print Dot Count: Max&gt;

Printing Region Setting (Memory Switch Setting)	Basic Calculated Pitch Offset (Set by DIP switches)	Initial Value				Maximum Value			
		dxL	dxH	dyL	dyH	Printable Region Width		Printable Region Width	
						X Direction	Y Direction	X Direction	Y Direction
72mm	203/180 DPI	64	2	84	7	72mm	117.3mm	72mm	300mm
52.5mm	203/180 DPI	164	1	8	7	52.5mm	117.3mm	52.5mm	300mm
50.8mm	203/180 DPI	150	1	84	7	50.8mm	117.3mm	50.8mm	300mm
52mm	203/180 DPI	160	1	84	7	52mm	117.3mm	52mm	300mm

Basic Calculated Pitch Initial Value: X = 1/180 (inch), Y = 1/360 (inch)

## • BSC10/TSP043

Page mode print region initial value (dxL, dxH, dyL, dyH) &lt;Print positions: ESC/POS compatible mode&gt;

Print region Setting (Memory Switch Setting)	Basic Calculated Pitch Correction (DIPSW Setting)	Initial Value (= Maximum Value)				Maximum Value			
		dxL	dxH	dyL	dyH	Printable Region Width		Printable Region Width	
						X Dir.	Y Dir.	X Dir.	Y Dir.
72mm	203DPI	64	2	84	7	72mm	117.3mm	72mm	300mm
	180DPI	0	2	126	6	64mm	103.9mm	64mm	300mm
50.8mm	203DPI	150	1	84	7	50.8mm	117.3mm	50.8mm	300mm
	180DPI	104	1	126	6	45mm	103.9mm	50.8mm	300mm

Basic calculated pitch initial value: X=1/180 (inch), Y=1/360 (inch)

Page mode print region initial value (dxL, dxH, dyL, dyH) &lt;Print positions: Maximum&gt;

Print region Setting (Memory Switch Setting)	Basic Calculated Pitch Correction (DIPSW Setting)	Initial Value (= Maximum Value)				Maximum Value			
		dxL	dxH	dyL	dyH	Printable Region Width		Printable Region Width	
						X Dir.	Y Dir.	X Dir.	Y Dir.
72mm	203/180DPI	64	2	84	7	72mm	117.3mm	72mm	300mm
50.8mm	203/180DPI	150	1	84	7	50.8mm	117.3mm	50.8mm	300mm

Basic calculated pitch initial value: X=1/180 (inch), Y=1/360 (inch)

## • TSP650IISK

Page mode print region initial value (dxL, dxH, dyL, dyH) &lt;Print positions: ESC/POS compatible mode&gt;

Print region Setting (Memory Switch Setting)	Basic Calculated Pitch Correction (DIPSW Setting)	Initial Value (= Maximum Value)						Maximum Value	
		dxL	dxH	dyL	dyH	Printable Region Width		Printable Region Width	
						X Dir.	Y Dir.	X Dir.	Y Dir.
72mm	203DPI	64	2	84	7	72mm	117.3mm	72mm	250mm
	180DPI	0	2	126	6	64mm	103.9mm	72mm	250mm
50.8mm	203DPI	150	1	84	7	50.8mm	117.3mm	50.8mm	250mm
	180DPI	104	1	126	6	45mm	103.9mm	50.8mm	250mm
34.5mm	203DPI	20	1	84	7	50.8mm	117.3mm	50.8mm	250mm
32mm	203DPI	0	1	84	7	50.8mm	117.3mm	50.8mm	250mm

Basic calculated pitch initial value: X=1/180 (inch), Y=1/360 (inch)

Page mode print region initial value (dxL, dxH, dyL, dyH) &lt;Print positions: Maximum&gt;

Print region Setting (Memory Switch Setting)	Basic Calculated Pitch Correction (DIPSW Setting)	Initial Value (= Maximum Value)						Maximum Value	
		dxL	dxH	dyL	dyH	Printable Region Width		Printable Region Width	
						X Dir.	Y Dir.	X Dir.	Y Dir.
72mm	203/180DPI	64	2	84	7	72mm	117.3mm	72mm	250mm
50.8mm	203/180DPI	150	1	84	7	50.8mm	117.3mm	50.8mm	250mm
34.5mm	203DPI	20	1	84	7	34.5mm	117.3mm	34.5mm	250mm
32mm	203DPI	0	1	84	7	32mm	117.3mm	32mm	250mm

Basic calculated pitch initial value: X=1/180 (inch), Y=1/360 (inch)

## 6-5-2 Usage Example of Page Mode

This section provides a detailed description of how to use the page mode.

The following outlines the representative command transmission procedures when using the page mode.

1. Page mode is used by the printer receiving the ESC L (Select page mode) command.
2. The print region is specified by the ESC W (Select print region in page mode) command.
3. The print direction is specified by the ESC T (Select character print direction in page mode) command.
4. Send print data.
5. The printer prints the print data send, using the FF (Print and recover page mode) command.
6. After printing, the printer recovers to standard mode.

### <Example 1: Sample Program using Basic>

(It is already possible to send to the printer using file #1 with an OPEN statement.)

```

100 PRINT #1, CHR$(&H1B); "L";
110 PRINT #1, CHR$(&H1B); "W"; CHR$(0); CHR$(0); CHR$(0); CHR$(0);
120 PRINT #1, CHR$(200); CHR$(0); CHR$(144); CHR$(1);
130 PRINT #1, CHR$(&H1B); "T"; CHR$(0);
140 PRINT #1, "Page mode lesson TEST 1"
150 PRINT #1, CHR$(&HC);
    
```

With the program in example 1, the print region of the size of 200 x 400 pitch is ensured from the origin point (0,0). Printing is performed on that first line.

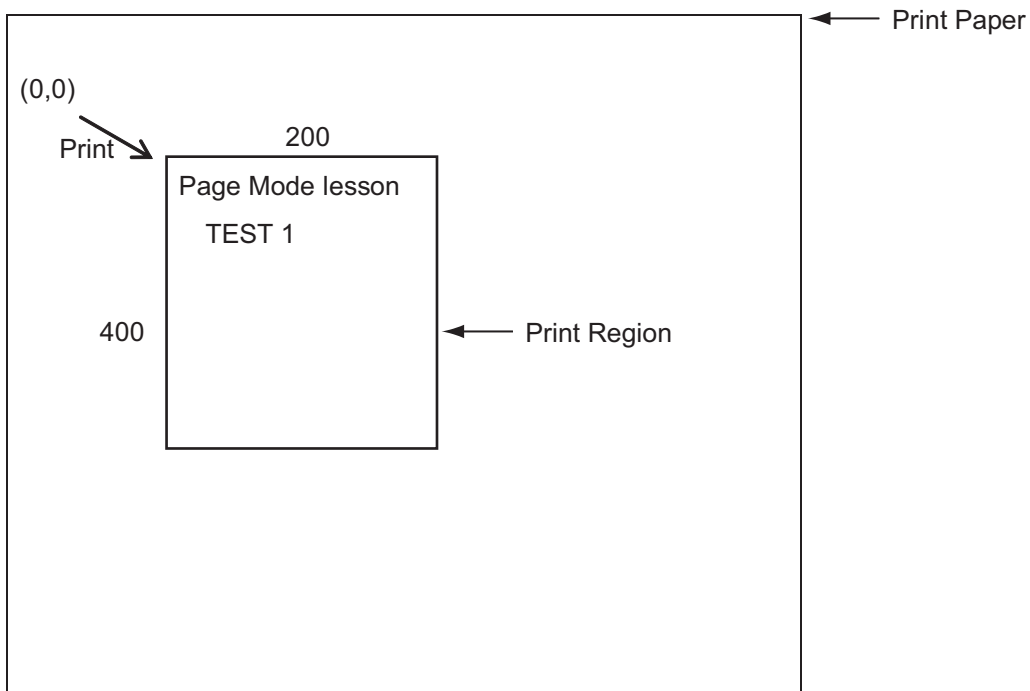

The reason for the line break between lesson and Test 1 in the figure above is because it was automatically inserted due to the fact that a space could not be inserted after lesson in the horizontal direction in the print range of 200 x 400 pitch. This line feed amount is a value specified by ESC 3 (Set line feed amount). Also, several print regions can be set until FF is executed. However, when print regions are overlapped, an OR operation is used for data that is newly written and data that was already written.

To delete only a portion of the buffered data, use the CAN (Cancel print data in page mode) command. CAN deletes all data in the print region currently specified. Therefore, specify the print region that encloses the portion to delete using ESC W, then use the CAN command to delete that data.

However, be careful because the portion in the specified print region, even if a portion of the characters, will be deleted.

<Example 2: Sample Program using Basic>

```

100 PRINT #1, CHR$(&H1B); "L";
110 PRINT #1, CHR$(&H1B); "W"; CHR$(0); CHR$(0); CHR$(0); CHR$(0);
120 PRINT #1, CHR$(200); CHR$(0); CHR$(144); CHR$(1);
130 PRINT #1, CHR$(&H1B); "T"; CHR$(0);
140 PRINT #1, "Page mode lesson 2 CAN command"
150 PRINT #1, CHR$(&HA);
160 PRINT #1, "ABCDEFGH IJKLMNOPQRST1234567890"
170 PRINT #1, CHR$(&HC);
    
```

Initially, send ESC L to switch to page mode (line number 100). Next, use ESC W to send eight arguments from xL to dyH to ensure the print region. In this example, to ensure a printer region of the size of 200 in the x direction and 400 in the y direction from the origin (0,0), send arguments in the order of 0,0,0,0,200,0,144,1. (Line numbers 110 to 120) Also, specify using ESC T. Specify the print direction with 0. (Line number 130) These settings send the print data "Page mode lesson 2 CAN command" and "ABCDEFGH IJKLMNOPQRST1234567890" (line numbers 140 to 160). By sending FF, (line number 170), the following will be printed.

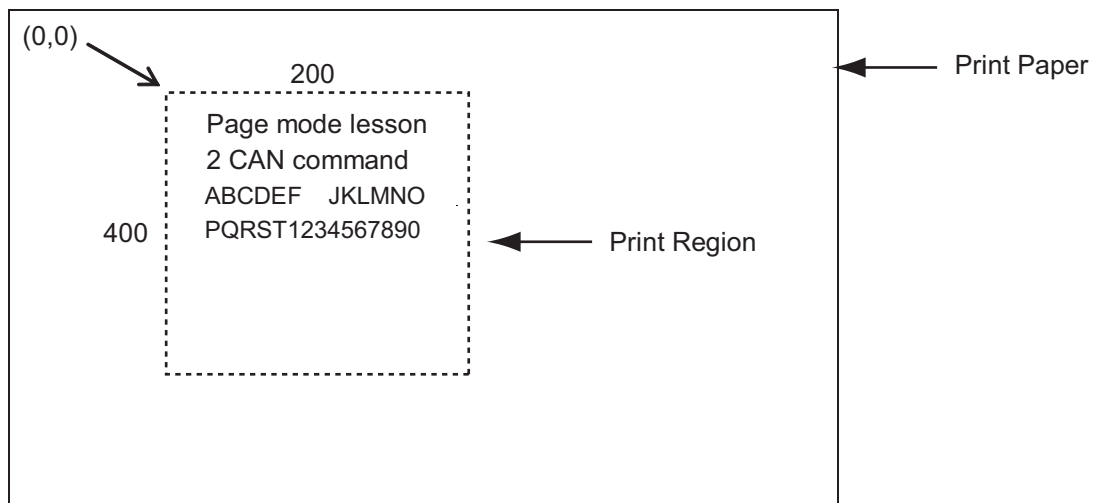

It is possible to delete a portion of the data by adding the next program before sending FF.

```

170 PRINT #1, CHR$(&H1B); "W"; CHR$(72); CHR$(0); CHR$(120); CHR$(0);
180 PRINT #1, CHR$(36); CHR$(0); CHR$(48); CHR$(0);
190 PRINT #1, CHR$(&H18);
200 PRINT #1, CHR$(&HC);
    
```

The character string GHI, in the figure below, is deleted as a result of adding the program above. Also, if deleting using the CAN command, a space is used without filling the deleted portion.

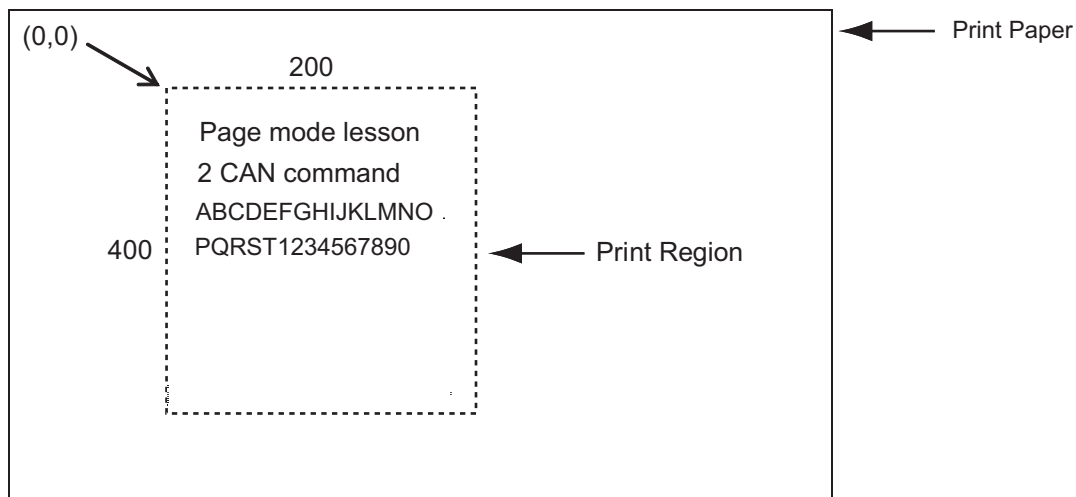

## 6-6 Appendix 6 CODE 128 Bar Codes, GS-1 Bar Codes

### 6-6-1 General Description of CODE 128 Bar Codes

With CODE 128 bar codes, it is possible to express one character of full ASCII128 character groups or two digits numbers with one bar code character by combining 103 bar code types and three types of code sets.

- Code Set A Expresses ASCII characters of 00H to 5FH
- Code Set B Expresses ASCII characters of 20H to 7FH
- Code Set C Expresses two-digit numbers with one character  
(100 types of 00 to 99)

Also in CODE 128, the following special characters are available.

- Shift characters (SHIFT)  
In code set A, 1 character immediately after a shift is handled as a character from code set B.  
In code set B, 1 character immediately after is handled as a character from code set A.  
Note that this is not used with code set C.
- Code set selection characters (Code A, Code B, Code C)  
Switches the following code set to A, B or C.
- Function characters (FNC1, FNC2, FNC3, FNC4)  
The use of function keys depends on the application. Note that only FNC1 is used with code set C.



**Code Tables**

## 1. Characters printable with code set A

Character	Transmission Data		Character	Transmission Data		Character	Transmission Data	
	Hex.	Decimal		Hex.	Decimal		Hex.	Decimal
NUL	00	0	(	28	40	P	50	80
SOH	01	1	)	29	41	Q	51	81
STX	02	2	*	2A	42	R	52	82
ETX	03	3	+	2B	43	S	53	83
EOT	04	4	,	2C	44	T	54	84
ENQ	05	5	-	2D	45	U	55	85
ACK	06	6	.	2E	46	V	56	86
BEL	07	7	/	2F	47	W	57	87
BS	08	8	0	30	48	X	58	88
HT	09	9	1	31	49	Y	59	89
LF	0A	10	2	32	50	Z	5A	90
VT	0B	11	3	33	51	[	5B	91
FF	0C	12	4	34	52	\	5C	92
CR	0D	13	5	35	53	]	5D	93
SO	0E	14	6	36	54	^	5E	94
SI	0F	15	7	37	55	_	5F	95
DLE	10	16	8	38	56	FNC1	7B,31	123,49
DC1	11	17	9	39	57	FNC2	7B,32	123,50
DC2	12	18	:	3A	58	FNC3	7B,33	123,51
DC3	13	19	;	3B	59	FNC4	7B,34	123,52
DC4	14	20	<	3C	60	SHIFT	7B,53	123,83
NAK	15	21	=	3D	61	CODE B	7B,42	123,66
SYN	16	22	>	3E	62	CODE C	7B,43	123,67
ETB	17	23	?	3F	63			
CAN	18	24	@	40	64			
EM	19	25	A	41	65			
SUB	1A	26	B	42	66			
ESC	1B	27	C	43	67			
FS	1C	28	D	44	68			
GS	1D	29	E	45	69			
RS	1E	30	F	46	70			
US	1F	31	G	47	71			
SP	20	32	H	48	72			
!	21	33	I	49	73			
"	22	34	J	4A	74			
#	23	35	K	4B	75			
\$	24	36	L	4C	76			
%	25	37	M	4D	77			
&	26	38	N	4E	78			
'	27	39	O	4F	79			

## 2. Characters printable with code set B

Character	Transmission Data		Character	Transmission Data		Character	Transmission Data	
	Hex.	Decimal		Hex.	Decimal		Hex.	Decimal
SP	20	32	H	48	72	p	70	112
!	21	33	I	49	73	q	71	113
"	22	34	J	4A	74	r	72	114
#	23	35	K	4B	75	s	73	115
\$	24	36	L	4C	76	t	74	116
%	25	37	M	4D	77	u	75	117
&	26	38	N	4E	78	v	76	118
'	27	39	O	4F	79	w	77	119
(	28	40	P	50	80	x	78	120
)	29	41	Q	51	81	y	79	121
*	2A	42	R	52	82	z	7A	122
+	2B	43	S	53	83	{	7B,7B	123
,	2C	44	T	54	84		7C	124
-	2D	45	U	55	85	}	7D	125
.	2E	46	V	56	86	to	7E	126
/	2F	47	W	57	87	DEL	7F	127
0	30	48	X	58	88	FNC1	7B,31	123,49
1	31	49	Y	59	89	FNC2	7B,32	123,50
2	32	50	Z	5A	90	FNC3	7B,33	123,51
3	33	51	[	5B	91	FNC4	7B,34	123,52
4	34	52	\	5C	92	SHIFT	7B,35	123,53
5	35	53	]	5D	93	CODE A	7B,41	123,65
6	36	54	^	5E	94	CODE C	7B,43	123,67
7	37	55	~	5F	95			
8	38	56	`	60	96			
9	39	57	a	61	97			
:	3A	58	b	62	98			
;	3B	59	c	63	99			
<	3C	60	d	64	100			
=	3D	61	e	65	101			
>	3E	62	f	66	102			
?	3F	63	g	67	103			
@	40	64	h	68	104			
A	41	65	i	69	105			
B	42	66	j	6A	106			
C	43	67	k	6B	107			
D	44	68	l	6C	108			
E	45	69	m	6D	109			
F	46	70	n	6E	110			
G	47	71	o	6F	111			

## 3. Characters printable with code set C

Character	Transmission Data		Character	Transmission Data		Character	Transmission Data	
	Hex.	Decimal		Hex.	Decimal		Hex.	Decimal
00	00	0	40	28	40	80	50	80
01	01	1	41	29	41	81	51	81
02	02	2	42	2A	42	82	52	82
03	03	3	43	2B	43	83	53	83
04	04	4	44	2C	44	84	54	84
05	05	5	45	2D	45	85	55	85
06	06	6	46	2E	46	86	56	86
07	07	7	47	2F	47	87	57	87
08	08	8	48	30	48	88	58	88
09	09	9	49	31	49	89	59	89
10	0A	10	50	32	50	90	5A	90
11	0B	11	51	33	51	91	5B	91
12	0C	12	52	34	52	92	5C	92
13	0D	13	53	35	53	93	5D	93
14	0E	14	54	36	54	94	5E	94
15	0F	15	55	37	55	95	5F	95
16	10	16	56	38	56	96	60	96
17	11	17	57	39	57	97	61	97
18	12	18	58	3A	58	98	62	98
19	13	19	59	3B	59	99	63	99
20	14	20	60	3C	60	FNC1	7B,31	123,49
21	15	21	61	3D	61	CODE A	7B,41	123,65
22	16	22	62	3E	62	CODE B	7B,42	123,66
23	17	23	63	3F	63			
24	18	24	64	40	64			
25	19	25	65	41	65			
26	1A	26	66	42	66			
27	1B	27	67	43	67			
28	1C	28	68	44	68			
29	1D	29	69	45	69			
30	1E	30	70	46	70			
31	1F	31	71	47	71			
32	20	32	72	48	72			
33	21	33	73	49	73			
34	22	34	74	4A	74			
35	23	35	75	4B	75			
36	24	36	76	4C	76			
37	25	37	77	4D	77			
38	26	38	78	4E	78			
39	27	39	79	4F	79			

## 6-6-2 General Description of GS-1 Bar Codes

Basic structure of data

Start character	FNC1	AI	Data	check digit A	check digit B	Stop character
Added automatically		(d1...dn)			Added automatically	

Connection structure of data

Start character	FNC1	AI	Data	check digit A	FNC1	AI	Data	check digit A	check digit B	Stop character
Added automatically		(d1...dn)						Added automatically		

The following four special characters(SP, “(, ”, “\*)” operate as shown below.

Special Characters			
Characters	Hex.	Decimal	
SP	20	32	The first SP after d1 is the data division identifier for identifying (AI). The SP is reflected by the HRI but is not included in the encoding data.
(	28	40	“(” is reflected by the HRI. This is useful when using “(, ”) to highlight the AI. It is not included in encoding data.
)	29	41	The first “)” after d1 is the data division identifier for identifying (AI). The “)” is reflected by the HRI but is not included in the encoding data.
*	2A	42	The check digit calculated by modulus 10 is inserted automatically at the position specified in “*”. The check digit is reflected in the HRI instead of the “*”.

Data added automatically is not entered in the HRI characters.

Special HRI characters are processed as shown below.

- Start characters (CODE A, CODE B, CODE C) are not printed in HRI characters.
- SP is used for HRI characters for function characters (FNC1 and FNC3) and control characters (00H to 1FH and 7FH).
- HRI characters for SP and “(, ”) are printed as they are.
- The check digit is printed in the “\*” position.

The available data ranges for each code set (CODE A, CODE B, CODE C) are shown in the following table. Bar code data for special characters (FNC1, FNC3) or “(, ”, “\*”, “{” sends double-byte characters as shown in the following table.

d		character		
Hex.	Decimal	CODE A	CODE B	CODE C
00	0	NUL		00
01	1	SOH		01
02	2	STX		02
03	3	ETX		03
04	4	EOT		04
05	5	ENQ		05
06	6	ACK		06
07	7	BEL		07
08	8	BS		08
09	9	HT		09
0A	10	LF		10
0B	11	VT		11
0C	12	FF		12
0D	13	CR		13
0E	14	SO		14
0F	15	SI		15
10	16	DLE		16
11	17	DC1		17
12	18	DC2		18
13	19	DC3		19
14	20	DC4		20
15	21	NAK		21
16	22	SYN		22
17	23	ETB		23
18	24	CAN		24
19	25	EM		25
1A	26	SUB		26
1B	27	ESC		27
1C	28	FS		28
1D	29	GS		29
1E	30	RS		30
1F	31	US		31
20	32			
21	33	!	!	33
22	34	"	"	34
23	35	#	#	35
24	36	\$	\$	36

d		character		
Hex.	Decimal	CODE A	CODE B	CODE C
25	37	%	%	37
26	38	&	&	38
27	39	'	'	39
7B, 28	123, 40	(	(	40
7B, 29	123, 41	)	)	41
7B, 2A	123, 42	*	*	42
2B	43	+	+	43
2C	44	,	,	44
2D	45	-	-	45
2E	46	.	.	46
2F	47	/	/	47
30	48	0	0	48
31	49	1	1	49
32	50	2	2	50
33	51	3	3	51
34	52	4	4	52
35	53	5	5	53
36	54	6	6	54
37	55	7	7	55
38	56	8	8	56
39	57	9	9	57
3A	58	:	:	58
3B	59	;	;	59
3C	60	<	<	60
3D	61	=	=	61
3E	62	>	>	62
3F	63	?	?	63
40	64	@	@	64
41	65	A	A	65
42	66	B	B	66
43	67	C	C	67
44	68	D	D	68
45	69	E	E	69
46	70	F	F	70
47	71	G	G	71
48	72	H	H	72
49	73	I	I	73

d		character		
Hex.	Decimal	CODE A	CODE B	CODE C
4A	74	J	J	74
4B	75	K	K	75
4C	76	L	L	76
4D	77	M	M	77
4E	78	N	N	78
4F	79	O	O	79
50	80	P	P	80
51	81	Q	Q	81
52	82	R	R	82
53	83	S	S	83
54	84	T	T	84
55	85	U	U	85
56	86	V	V	86
57	87	W	W	87
58	88	X	X	88
59	89	Y	Y	89
5A	90	Z	Z	90
5B	91	[	[	91
5C	92	\	\	92
5D	93	]	]	93
5E	94	^	^	94
5F	95	_	_	95
60	96	/	`	96
61	97	/	a	97
62	98	/	b	98
63	99	/	c	99
64	100	/	d	/
65	101	/	e	/
66	102	/	f	/
67	103	/	g	/
68	104	/	h	/
69	105	/	i	/
6A	106	/	j	/
6B	107	/	k	/
6C	108	/	l	/
6D	109	/	m	/
6E	110	/	n	/

d		character		
Hex.	Decimal	CODE A	CODE B	CODE C
6F	111	/	o	/
70	112	/	p	/
71	113	/	q	/
72	114	/	r	/
73	115	/	s	/
74	116	/	t	/
75	117	/	u	/
76	118	/	v	/
77	119	/	w	/
78	120	/	x	/
79	121	/	y	/
7A	122	/	z	/
7B, 7B	123, 123	/	{	/
7C	124	/		/
7D	125	/	}	/
7E	126	/	~	/
7F	127	/	DEL	/

d		character		
Hex.	Decimal	CODE A	CODE B	CODE C
7B, 31	123, 49	FNC1	FNC1	FNC1
7B, 33	123, 51	FNC3	FNC3	/
20	32	SP	SP	SP
28	40	(	(	(
29	41	)	)	)
2A	42	*	*	*

### 6-6-3 GS1 Databar Omnidirectional

Sends 13 digits of data except for AI (application identifiers) and check digits.

AI ("01") is added automatically.

One check digit is added automatically.

When HRI printing is enabled, 18 digits of ["(01)", (d1...d13), check digit] are printed by the HRI.

When the setting for the bar code height is smaller than [module width x33], the bar code height is printed at the [module width x33]. (Except for HRI heights)

### 6-6-4 GS1 Databar Truncated

Sends 13 digits of data except for AI (application identifiers) and check digits.

AI ("01") is added automatically.

One check digit is added automatically.

When HRI printing is enabled, 18 digits of ["(01)", (d1...d13), check digit] are printed by the HRI.

When the setting for the bar code height is smaller than [module width x13], the bar code height is printed at the [module width x13]. (Except for HRI heights)

### 6-6-5 GS1 Databar Limited

Sends 13 digits of data except for AI (application identifiers) and check digits.

When HRI printing is enabled, 18 digits of ["(01)", (d1...d13), check digit] are printed by the HRI.

When the setting for the bar code height is smaller than [module width x10], the bar code height is printed at the [module width x10]. (Except for HRI heights)

### 6-6-6 GS1 Databar Expanded

When sending special characters (FNC1) or ("(", ")"), the following double-byte data is sent.

Data	Send data		
	ASCII	Hex.	Decimal
FNC1	{ + 1	7B + 31	123 + 49
(	{ + (	7B + 28	123 + 40
)	{ + )	7B + 29	123 + 41

The special character ("(", ")") is processed as shown in the following table.

Special characters			
character	Hex.	Decimal	
(	28	40	"(" is entered in the HRI character. AI can be highlighted by using in combination with "). " " is not encoded.
)	29	41	The first ")" after d1 is handled as an AI and the data divider. ")" is entered in the HRI character. ")" " is not encoded.

When HRI character printing is enabled, special characters are handled in the HRI as shown below.

Control characters (FNC1) are not printed.

Special characters ("(", ")") are printed.

Bar code data [{" + ("(", ")")] is printed as ("(", ")").

When the setting for the bar code height is smaller than [module width x34], the bar code height is printed at the [module width x34]. (Except for HRI heights)

## 6-7 Appendix 7 Maximum Number of Input Characters for Each Version of QR Code

### 1) Model 1 Version and Maximum Number of Input Characters

Version	Cell Count on One Side	Mistake Correction Level	Number of Characters	English Characters	Binary	Kanji
1	21	L	40	24	17	10
		M	33	20	14	8
		Q	25	15	11	6
		H	16	10	7	4
2	25	L	81	49	34	20
		M	66	40	28	17
		Q	52	31	22	13
		H	33	20	14	8
3	29	L	131	79	55	33
		M	100	60	42	25
		Q	81	49	34	20
		H	52	31	22	13
4	33	L	186	113	78	48
		M	138	84	58	35
		Q	114	69	48	29
		H	76	46	32	19
5	37	L	253	154	106	65
		M	191	116	80	49
		Q	157	95	66	40
		H	105	63	44	27
6	41	L	321	194	134	82
		M	249	151	104	64
		Q	201	122	84	51
		H	133	81	56	34
7	45	L	402	244	168	103
		M	311	188	130	80
		Q	253	154	106	65
		H	167	101	70	43
8	49	L	493	299	206	126
		M	378	229	158	97
		Q	301	183	126	77
		H	203	123	85	52
9	53	L	585	354	244	150
		M	441	267	184	113
		Q	369	223	154	94
		H	239	145	100	61
10	57	L	690	418	287	177
		M	526	319	219	135
		Q	433	262	180	111
		H	291	176	121	74
11	61	L	800	485	333	205
		M	608	368	253	156
		Q	493	299	205	126
		H	342	207	142	87
12	65	L	915	555	381	234
		M	694	421	289	178
		Q	579	351	241	148
		H	390	236	162	100
13	69	L	1030	624	429	264
		M	790	479	329	202
		Q	656	398	273	168
		H	454	275	189	116
14	73	L	1167	707	486	299
		M	877	531	365	225
		Q	738	447	307	189
		H	498	302	207	127



## 2) Model 2 Version and Maximum Number of Input Characters

Version	Cell Count on One Side	Mistake Correction Level	Number of Characters	English Characters	Binary	Kanji
1	21	L	41	25	17	10
		M	34	20	14	8
		Q	27	16	11	7
		H	17	10	7	4
2	25	L	77	47	32	20
		M	63	38	26	16
		Q	48	29	20	12
		H	34	20	14	8
3	29	L	127	77	53	32
		M	101	61	42	26
		Q	77	47	32	20
		H	58	35	24	15
4	33	L	187	114	78	48
		M	149	90	62	38
		Q	111	67	46	28
		H	82	50	34	21
5	37	L	255	154	106	65
		M	202	122	84	52
		Q	144	87	60	37
		H	106	64	44	27
6	41	L	322	195	134	82
		M	255	154	106	65
		Q	178	108	74	45
		H	139	84	58	36
7	45	L	370	224	154	95
		M	293	178	122	75
		Q	207	125	86	53
		H	154	93	64	39
8	49	L	461	279	192	118
		M	365	221	152	93
		Q	259	157	108	66
		H	202	122	84	52
9	53	L	552	335	230	141
		M	432	262	180	111
		Q	312	189	130	80
		H	235	143	98	60
10	57	L	652	395	271	167
		M	513	311	213	131
		Q	364	221	151	93
		H	288	174	119	74
11	61	L	772	468	321	198
		M	604	366	251	155
		Q	427	259	177	109
		H	331	200	137	85
12	65	L	883	535	367	226
		M	691	419	287	177
		Q	489	296	203	125
		H	374	227	155	96
13	69	L	1022	619	425	262
		M	796	483	331	204
		Q	580	352	241	149
		H	427	259	177	109
14	73	L	1101	667	458	282
		M	871	528	362	223
		Q	621	376	258	159
		H	468	283	194	120
15	77	L	1250	758	520	320
		M	991	600	412	254
		Q	703	426	292	180
		H	530	321	220	136

Version	Cell Count on One Side	Mistake Correction Level	Number of Characters	English Characters	Binary	Kanji
16	81	L	1408	854	586	361
		M	1082	656	450	277
		Q	775	470	322	198
		H	602	365	250	154
17	85	L	1548	938	644	397
		M	1212	734	504	310
		Q	876	531	364	224
		H	674	408	280	173
18	89	L	1725	1046	718	442
		M	1346	816	560	345
		Q	948	574	394	243
		H	746	452	310	191
19	93	L	1903	1153	792	488
		M	1500	909	624	384
		Q	1063	644	442	272
		H	813	493	338	208
20	97	L	2061	1249	858	528
		M	1600	970	666	410
		Q	1159	702	482	297
		H	919	557	382	235
21	101	L	2232	1352	929	572
		M	1708	1035	711	438
		Q	1224	742	509	314
		H	969	587	403	248
22	105	L	2409	1460	1003	618
		M	1872	1134	779	480
		Q	1358	823	565	348
		H	1056	640	439	270
23	109	L	2620	1588	1091	672
		M	2059	1248	857	528
		Q	1468	890	611	376
		H	1108	672	461	284
24	113	L	2812	1704	1171	721
		M	2188	1326	911	561
		Q	1588	963	661	407
		H	1228	744	511	315
25	117	L	3057	1853	1273	784
		M	2395	1451	997	614
		Q	1718	1041	715	440
		H	1286	779	535	330
26	121	L	3283	1990	1367	842
		M	2544	1542	1059	652
		Q	1804	1094	751	462
		H	1425	864	593	365
27	125	L	3514	2132	1465	902
		M	2701	1637	1125	692
		Q	1933	1172	805	496
		H	1501	910	625	385
28	129	L	3669	2223	1528	940
		M	2857	1732	1190	732
		Q	2085	1263	868	534
		H	1581	958	658	405
29	133	L	3909	2369	1628	1002
		M	3035	1839	1264	778
		Q	2181	1322	908	559
		H	1677	1016	698	430
30	137	L	4158	2520	1732	1066
		M	3289	1994	1370	843
		Q	2358	1429	982	604
		H	1782	1080	742	457

Version	Cell Count on One Side	Mistake Correction Level	Number of Characters	English Characters	Binary	Kanji
31	141	L	4417	2677	1840	1132
		M	3486	2113	1452	894
		Q	2473	1499	1030	634
		H	1897	1150	790	486
32	145	L	4686	2840	1952	1201
		M	3693	2238	1538	947
		Q	2670	1618	1112	684
		H	2022	1226	842	518
33	149	L	4965	3009	2068	1273
		M	3909	2369	1628	1002
		Q	2805	1700	1168	719
		H	2157	1307	898	553
34	153	L	5253	3183	2188	1347
		M	4134	2506	1722	1060
		Q	2949	1787	1228	756
		H	2301	1394	958	590
35	157	L	5529	3351	2303	1417
		M	4343	2632	1809	1113
		Q	3081	1867	1283	790
		H	2361	1431	983	605
36	161	L	5836	3537	2431	1496
		M	4588	2780	1911	1176
		Q	3244	1966	1351	832
		H	2524	1530	1051	647
37	165	L	6153	3729	2563	1577
		M	4775	2894	1989	1224
		Q	3417	2071	1423	876
		H	2625	1591	1093	673
38	169	L	6479	3927	2699	1661
		M	5039	3054	2099	1292
		Q	3599	2181	1499	923
		H	2735	1658	1139	701
39	173	L	6743	4087	2809	1729
		M	5313	3220	2213	1362
		Q	3791	2298	1579	972
		H	2927	1774	1219	750
40	177	L	7089	4296	2953	1817
		M	5596	3391	2331	1435
		Q	3993	2420	1663	1024
		H	3057	1852	1273	784

## 6-8 Appendix 8 Explanation of Print Startup Control Starting Printing When Set to Page Units

When print startup control is set to page units, printing starts when the image buffer length is full or the following commands are run.

If the following commands are not received, start printing after a 1-second timeout.

For details on image buffer length and how to set print startup control, see the product specifications manual.

### Print starting trigger

- Cutter command: <GS> V n, <GS> V m n
- BM detection command: <GS> <FF>, <FF> (When BM is valid)
- Print startup command: <ESC><GS> g 0 m n

**6-9 Appendix 9**
**Explanation of Printing NV bit image data defined by  
 “GS ( L <fn=67>” or “GS ( 8 <fn=67>”, by “FS p” command**

The portion of NV bit image data defined by “GS ( L <fn=67>” or “GS ( 8 <fn=67>” is possible to print by FS p n command. The following table shows the contrast table of the parameter at that time. <SP> in the table below is space (20H).

n	kc1	kc2	n	kc1	kc2	n	kc1	kc2	n	kc1	kc2
1	0	1	64	6	4	128	<SP>	<	192	<SP>	
2	0	2	65	6	5	129	<SP>	=	193	<SP>	]
3	0	3	66	6	6	130	<SP>	>	194	<SP>	~
4	0	4	67	6	7	131	<SP>	?	195	!	<SP>
5	0	5	68	6	8	132	<SP>	@	196	!	!
6	0	6	69	6	9	133	<SP>	A	197	!	”
7	0	7	70	7	0	134	<SP>	B	198	!	#
8	0	8	71	7	1	135	<SP>	C	199	!	\$
9	0	9	72	7	2	136	<SP>	D	200	!	%
10	1	0	73	7	3	137	<SP>	E	201	!	&
11	1	1	74	7	4	138	<SP>	F	202	!	'
12	1	2	75	7	5	139	<SP>	G	203	!	(
13	1	3	76	7	6	140	<SP>	H	204	!	)
14	1	4	77	7	7	141	<SP>	I	205	!	*
15	1	5	78	7	8	142	<SP>	J	206	!	+
16	1	6	79	7	9	143	<SP>	K	207	!	.
17	1	7	80	8	0	144	<SP>	L	208	!	-
18	1	8	81	8	1	145	<SP>	M	209	!	.
19	1	9	82	8	2	146	<SP>	N	210	!	/
20	2	0	83	8	3	147	<SP>	O	211	!	0
21	2	1	84	8	4	148	<SP>	P	212	!	1
22	2	2	85	8	5	149	<SP>	Q	213	!	2
23	2	3	86	8	6	150	<SP>	R	214	!	3
24	2	4	87	8	7	151	<SP>	S	215	!	4
25	2	5	88	8	8	152	<SP>	T	216	!	5
26	2	6	89	8	9	153	<SP>	U	217	!	6
27	2	7	90	9	0	154	<SP>	V	218	!	7
28	2	8	91	9	1	155	<SP>	W	219	!	8
29	2	9	92	9	2	156	<SP>	X	220	!	9
30	3	0	93	9	3	157	<SP>	Y	221	!	:
31	3	1	94	9	4	158	<SP>	Z	222	!	:
32	3	2	95	9	5	159	<SP>	[	223	!	<
33	3	3	96	9	6	160	<SP>	¥	224	!	=
34	3	4	97	9	7	161	<SP>	]	225	!	>
35	3	5	98	9	8	162	<SP>	^	226	!	?
36	3	6	99	9	9	163	<SP>	_	227	!	@
37	3	7	100	<SP>	<SP>	164	<SP>	`	228	!	A
38	3	8	101	<SP>	!	165	<SP>	a	229	!	B
39	3	9	102	<SP>	”	166	<SP>	b	230	!	C
40	4	0	103	<SP>	#	167	<SP>	c	231	!	D
41	4	1	104	<SP>	\$	168	<SP>	d	232	!	E
42	4	2	105	<SP>	%	169	<SP>	e	233	!	F
43	4	3	106	<SP>	&	170	<SP>	f	234	!	G
44	4	4	107	<SP>	'	171	<SP>	g	235	!	H
45	4	5	108	<SP>	(	172	<SP>	h	236	!	I
46	4	6	109	<SP>	)	173	<SP>	i	237	!	J
47	4	7	110	<SP>	*	174	<SP>	j	238	!	K
48	4	8	111	<SP>	+	175	<SP>	k	239	!	L
49	4	9	112	<SP>	.	176	<SP>	l	240	!	M
50	5	0	113	<SP>	-	177	<SP>	m	241	!	N
51	5	1	114	<SP>	.	178	<SP>	n	242	!	O
52	5	2	115	<SP>	/	179	<SP>	o	243	!	P
53	5	3	116	<SP>	0	180	<SP>	p	244	!	Q
54	5	4	117	<SP>	1	181	<SP>	q	245	!	R
55	5	5	118	<SP>	2	182	<SP>	r	246	!	S
56	5	6	119	<SP>	3	183	<SP>	s	247	!	T
57	5	7	120	<SP>	4	184	<SP>	t	248	!	U
58	5	8	121	<SP>	5	185	<SP>	u	249	!	V
59	5	9	122	<SP>	6	186	<SP>	v	250	!	W
60	6	0	123	<SP>	7	187	<SP>	w	251	!	X
61	6	1	124	<SP>	8	188	<SP>	x	252	!	Y
62	6	2	125	<SP>	9	189	<SP>	y	253	!	Z
63	6	3	126	<SP>	:	190	<SP>	z	254	!	[
			127	<SP>	:	191	<SP>	{	255	!	¥

## **6-10 Appendix 10 Special Specifications when the Bluetooth Interface (IFBD-HB03) is used**

### **6-10-1 Self-printing**

1) When the Bluetooth information is printed at the end of self-printing, the communication with the host device is terminated.

Therefore, if you continue to transmit data using commands after self-printing, you need to open the virtual COM port again.

## 7. APPENDIX COMMAND LIST BY MODEL

### 7-1 RS-232C Interface

#### • Standard Commands

Commands	Model Name														
	TSP700	TSP600	TSP800	TUP900	TSP1000	TSP700II	TSP650	TUP500	TSP800II	FVP10	BSC10	TSP043	TSP650II	TSP650IIISK	
HT	○	○	○	○	○	○	○	○	○	○	○	○	○	○	
LF	○	○	○	○	○	○	○	○	○	○	○	○	○	○	
FF	○	○	○	○	○	○	○	○	○	○	○	○	○	○	
CR	X	X	X	X	X	X	X	X	X	X	X	X	X	X	
CAN	○	○	○	○	○	○	○	○	○	○	○	○	○	○	
DLE EOT	Spec. A	Spec. A	Spec. A	Spec. B	Spec. B	Spec. B-1 Ver. 1.4 or older Spec. B-2 Ver. 2.0 or later	Spec. B-1 Ver. 1.4 or older Spec. B-2 Ver. 2.0 or later	Spec. B-1 Ver. 1.0 or older Spec. B-2 Ver. 2.0 or later	Spec. B-2	Spec. B-2	Spec. B-2	Spec. B-2	Spec. B-2	Spec. B-2	
DLE ENQ	X	○	X	X	X	X	X	X	X	X	X	X	X	X	
DLE DC4	○	○	○	X	X	○	○	X	○	○	○	○	○	○	
ESC FF	○	○	○	○	○	○	○	○	○	○	○	○	○	○	
ESC SP	○	○	○	○	○	○	○	○	○	○	○	○	○	○	
ESC !	○	○	○	○	○	○	○	○	○	○	○	○	○	○	
ESC \$	○	○	○	○	○	○	○	○	○	○	○	○	○	○	
ESC %	○	○	○	○	○	○	○	○	○	○	○	○	○	○	
ESC &	○	○	○	○	○	○	○	○	○	○	○	○	○	○	
ESC *	Spec. A	Spec. A	Spec. A	Spec. A	Spec. A	Spec. A	Spec. A	Spec. A	Spec. A	Spec. A	Spec. A	Spec. A	Spec. B	Spec. B	
ESC -	○	○	○	○	○	○	○	○	○	○	○	○	○	○	
ESC 2	○	○	○	○	○	○	○	○	○	○	○	○	○	○	
ESC 3	○	○	○	○	○	○	○	○	○	○	○	○	○	○	
ESC =	○	○	○	X	X	○	○	○	○	○	○	○	○	○	
ESC ?	○	○	○	○	○	○	○	○	○	○	○	○	○	○	
ESC @	○	○	○	○	○	○	○	○	○	○	○	○	○	○	
ESC D	○	○	○	○	○	○	○	○	○	○	○	○	○	○	
ESC E	○	○	○	○	○	○	○	○	○	○	○	○	○	○	
ESC G	○	○	○	○	○	○	○	○	○	○	○	○	○	○	
ESC J	○	○	○	○	○	○	○	○	○	○	○	○	○	○	
ESC L	○	○	○	○	○	○	○	○	○	○	○	○	○	○	
ESC M	○	○	○	○	○	○	○	○	○	○	○	○	○	○	
ESC R	Spec. A	Spec. A	Spec. A	Spec. A	Spec. A	Spec. A	Spec. A	Spec. A	Spec. A	Spec. A	Spec. A Ver. 1.0 to Ver. 1.2 Spec. B Ver. 1.3 or later	Spec. A Ver. 1.0 to Ver. 1.2 Spec. B Ver. 1.3 or later	Spec. B	Spec. B	
ESC S	○	○	○	○	○	○	○	○	○	○	○	○	○	○	
ESC T	○	○	○	○	○	○	○	○	○	○	○	○	○	○	
ESC V	○	○	○	○	○	○	○	○	○	○	○	○	○	○	
ESC W	○	○	○	○	○	○	○	○	○	○	○	○	○	○	
ESC \	○	○	○	○	○	○	○	○	○	○	○	○	○	○	
ESC a	○	○	○	○	○	○	○	○	○	○	○	○	○	○	
ESC c 3	X	X	X	X	X	X	X	X	X	X	X	X	X	X	
ESC c 4	○	○	○	○	○	○	○	○	○	○	○	○	○	○	
ESC c 5	○	○	○	○	○	○	○	○	○	○	○	○	○	○	
ESC d	○	○	○	○	○	○	○	○	○	○	○	○	○	○	
ESC p	○	○	○	X	X	○	○	X	○	○	○	○	○	○	
ESC t	Spec. A	Spec. A	Spec. A	Spec. A	Spec. A	Spec. A	Spec. A	Spec. A	Spec. A	Spec. A	Spec. B	Spec. B	Spec. B	Spec. B	
ESC {	○	○	○	○	○	○	○	○	○	○	○	○	○	○	

Commands	Model Name													
	TSP700	TSP600	TSP800	TUP900	TSP1000	TSP700II	TSP650	TUP500	TSP800II	FVP10	BSC10	TSP043	TSP650II	TSP650IIISK
FS g 1	X	X	X	X	X	X	X	X	X	X	X	X	X	X
FS g 2	X	X	X	X	X	X	X	X	X	X	X	X	X	X
FS p	o	o	o	o	o	o	o	o	o	o	o	o	o	o
FS q	o	o	o	o	o	o	o	o	o	o	o	o	o	o
GS !	o	o	o	o	o	o	o	o	o	o	o	o	o	o
GS \$	o	o	o	o	o	o	o	o	o	o	o	o	o	o
GS *	o	o	o	o	o	o	o	o	o	o	o	o	o	o
GS ( A	o	o	o	o	o	o	o	o	o	o	o	o	o	o
GS (K (fn=49)	X	X	X	Spec. A	Spec. A	Spec. A	Spec. A	Spec. A	Spec. B	Spec. B	Spec. C	Spec. C	Spec. C	X
GS (K (fn=50)	X	X	X	X	X	X	X	X	X	X	Spec. A	Spec. A	Spec. A	Spec. B
GS (L (fn=48)	X	X	X	X	X	X	X	X	X	X	o	o	o	o
GS (L (fn=51)	X	X	X	X	X	X	X	X	X	X	o	o	o	o
GS (L (fn=64)	X	X	X	X	X	X	X	X	X	X	o	o	o	o
GS (L (fn=65)	X	X	X	X	X	X	X	X	X	X	o	o	o	o
GS (L (fn=66)	X	X	X	X	X	X	X	X	X	X	o	o	o	o
GS (L (fn=67)	X	X	X	X	X	X	X	X	X	X	o	o	o	o
GS (L (fn=69)	X	X	X	X	X	X	X	X	X	X	o	o	o	o
GS (L (fn=112)	X	X	X	X	X	Ver.2.0 or later	Ver.2.0 or later	o	o	o	o	o	o	o
GS 8 L (fn=48)	X	X	X	X	X	X	X	X	X	X	o	o	o	o
GS 8 L (fn=51)	X	X	X	X	X	X	X	X	X	X	o	o	o	o
GS 8 L (fn=64)	X	X	X	X	X	X	X	X	X	X	o	o	o	o
GS 8 L (fn=65)	X	X	X	X	X	X	X	X	X	X	o	o	o	o
GS 8 L (fn=66)	X	X	X	X	X	X	X	X	X	X	o	o	o	o
GS 8 L (fn=67)	X	X	X	X	X	X	X	X	X	X	o	o	o	o
GS 8 L (fn=69)	X	X	X	X	X	X	X	X	X	X	o	o	o	o
GS 8L (fn=112)	X	X	X	X	X	Ver.2.0 or later	Ver.2.0 or later	o	o	o	o	o	o	o
GS ( N	X	X	X	o	o	o	o	o	o	o	X	X	o	X
GS ( k (cn=48,fn=65)	X	X	X	X	X	X	X	X	X	X	o	o	o	o
GS ( k (cn=48,fn=66)	X	X	X	X	X	X	X	X	X	X	o	o	o	o
GS ( k (cn=48,fn=67)	X	X	X	X	X	X	X	X	X	X	o	o	o	o
GS ( k (cn=48,fn=68)	X	X	X	X	X	X	X	X	X	X	o	o	o	o
GS ( k (cn=48,fn=69)	X	X	X	X	X	X	X	X	X	X	o	o	o	o
GS ( k (cn=48,fn=70)	X	X	X	X	X	X	X	X	X	X	o	o	o	o
GS ( k (cn=48,fn=80)	X	X	X	X	X	X	X	X	X	X	o	o	o	o
GS ( k (cn=48,fn=81)	X	X	X	X	X	X	X	X	X	X	o	o	o	o
GS ( k (cn=48,fn=82)	X	X	X	X	X	X	X	X	X	X	o Ver. 1.8 or older x Ver.1.9 or later	o	o Ver. 1.2 or older x Ver.2.0 or later	X
GS ( k (cn=49,fn=65)	X	X	X	X	X	X	X	X	X	X	o	o	o	o
GS ( k (cn=49,fn=67)	X	X	X	X	X	X	X	X	X	X	o	o	o	o
GS ( k (cn=49,fn=69)	X	X	X	X	X	X	X	X	X	X	o	o	o	o
GS ( k (cn=49,fn=80)	X	X	X	X	X	X	X	X	X	X	o	o	o	o
GS ( k (cn=49,fn=81)	X	X	X	X	X	X	X	X	X	X	o	o	o	o
GS ( k (cn=49,fn=82)	X	X	X	X	X	X	X	X	X	X	o Ver. 1.8 or older x Ver.1.9 or later	o	o Ver. 1.2 or older x Ver.2.0 or later	X



Commands	Model Name													
	TSP700	TSP600	TSP800	TUP900	TSP1000	TSP700II	TSP650	TUP500	TSP800II	FVP10	BSC10	TSP043	TSP650II	TSP650IIISK
GS ( k (cn=51,fn=67)	X	X	X	X	X	X	X	X	X	X	X	X	Ver.2.0 or later	o
GS ( k (cn=51,fn=71)	X	X	X	X	X	X	X	X	X	X	X	X	Ver.2.0 or later	o
GS ( k (cn=51,fn=80)	X	X	X	X	X	X	X	X	X	X	X	X	Ver.2.0 or later	o
GS ( k (cn=51,fn=81)	X	X	X	X	X	X	X	X	X	X	X	X	Ver.2.0 or later	o
GS ( k (cn=52,fn=67)	X	X	X	X	X	X	X	X	X	X	X	X	Ver.2.0 or later	o
GS ( k (cn=52,fn=71)	X	X	X	X	X	X	X	X	X	X	X	X	Ver.2.0 or later	o
GS ( k (cn=52,fn=72)	X	X	X	X	X	X	X	X	X	X	X	X	Ver.2.0 or later	o
GS ( k (cn=52,fn=80)	X	X	X	X	X	X	X	X	X	X	X	X	Ver.2.0 or later	o
GS ( k (cn=52,fn=81)	X	X	X	X	X	X	X	X	X	X	X	X	Ver.2.0 or later	o
GS /	o	o	o	o	o	o	o	o	o	o	o	o	o	o
GS :	o	o	o	o	o	o	o	o	o	o	o	o	o	o
GS B	o	o	o	o	o	o	o	o	o	o	o	o	o	o
GS C 0	X	X	X	o	o	o	o	o	o	o	X	X	o	o
GS C 1	X	X	X	o	o	o	o	o	o	o	X	X	o	o
GS C 2	X	X	X	o	o	o	o	o	o	o	X	X	o	o
GS C :	X	X	X	o	o	o	o	o	o	o	X	X	o	o
GS E	X	X	X	Spec. A	Spec. A	Spec. A	Spec. A	Spec. A	Spec. A	Spec. A	X	X	Spec. A	Spec. B
GS H	o	o	o	o	o	o	o	o	o	o	o	o	o	o
GS I	Spec. A	Spec. A	Spec. A	Spec. A Ver. 4.4 or older Spec. B Ver. 4.5 or later	Spec. A	Spec. A Ver. 3.0 or older Spec. B Ver. 3.1 or later	Spec. A Ver. 3.0 or older Spec. B Ver. 3.1 or later	Spec. A Ver. 3.1 or older Spec. B Ver. 3.2 or later	Spec. A	Spec. B	Spec. B	Spec. B	Spec. B	Spec. B
GS L	o	o	o	o	o	o	o	o	o	o	o	o	o	o
GS P	o	o	o	X	X	o	o	X	o	o	o	o	o	o
GS T	X	X	X	o	o	o	o	o	o	o	o	o	o	o
GS V	o	o	o	o	o	o	o	o	o	o	o	o	o	o
GS W	o	o	o	o	o	o	o	o	o	o	o	o	o	o
GS \	o	o	o	o	o	o	o	o	o	o	o	o	o	o
GS ^	o	o	o	o	o	o	o	o	o	o	o	o	o	o
GS c	X	X	X	X	X	X	X	X	X	X	Ver. 1.3 or later	Ver. 1.3 or later	o	o
GS f	X	X	X	o	o	o	o	o	o	o	X	X	o	o
GS h	o	o	o	o	o	o	o	o	o	o	o	o	o	o
GS k	Spec. A Spec. B	Spec. A Spec. B	Spec. A Spec. B	Spec. A Spec. B	Spec. A Spec. B	Spec. A Spec. B	Spec. A Spec. B	Spec. A Spec. B	Spec. A Spec. B	Spec. A Spec. B	Spec. A Spec. B	Spec. A Spec. B	Spec. A,B Ver. 1.2 or older Spec. A,B,C Ver.2.0 or later	Spec. A Spec. B Spec. C
GS r	o	o	o	o	o	o	o	o	o	o	o	o	o	o
GS v 0	o	o	o	o	o	o	o	o	o	o	o	o	o	o
GS w	o	o	o	o	o	o	o	o	o	o	o	o	o	o

## • Kanji Control Commands (DBCS Settings, Kanji Specifications Only)

Commands	Model Name													
	TSP700	TSP600	TSP800	TUP900	TSP1000	TSP700II	TSP650	TUP500	TSP800II	FVP10	BSC10	TSP043	TSP650I	TSP650IIISK
FS !	○	○	○	○	○	○	○	○	○	○	○	○	○	○
FS &	Spec. A	Spec. A	Spec. A	Spec. A	Spec. A	Spec. A	Spec. A	Spec. A	Spec. A	Spec. A	Spec. B	Spec. B	Spec. A	Spec. A
FS -	○	○	○	○	○	○	○	○	○	○	○	○	○	○
FS .	○	○	○	○	○	○	○	○	○	○	○	○	○	○
FS 2	○	○	○	○	○	○	○	○	○	○	○	○	○	○
FS C	○	○	○	○	○	○	○	○	○	○	X	X	○	○
FS S	○	○	○	○	○	○	○	○	○	○	○	○	○	○
FS W	○	○	○	○	○	○	○	○	○	○	○	○	○	○

## • ESC/POS Black Mark Related Commands (When black marks are effective)

Commands	Model Name													
	TSP700	TSP600	TSP800	TUP900	TSP1000	TSP700II	TSP650	TUP500	TSP800II	FVP10	BSC10	TSP043	TSP650II	TSP650IIISK
FF	○	○	○	○	○	○	X	○	○	○	○	○	X	X
DLE ENQ	○	○	○	○	○	○	X	○	○	○	○	○	X	X
GS FF	X	X	X	○	○	○	X	○	○	○	○	○	X	X
GS ( F	X	X	X	○	○	X	X	X	X	X	X	X	X	X
GS ( M n=1	X	X	X	○	○	X	X	X	X	X	X	X	X	X
GS ( M n=2	X	X	X	○	○	X	X	X	X	X	X	X	X	X
GS ( M n=3	X	X	X	○	○	X	X	X	X	X	X	X	X	X
GS <	○	○	○	X	X	○	X	X	○	○	○	○	X	X
GS V	○	○	○	○	○	○	X	○	○	○	○	○	X	X

## • STAR Original Commands

Commands	Model Name													
	TSP700	TSP600	TSP800	TUP900	TSP1000	TSP700II	TSP650	TUP500	TSP800II	FVP10	BSC10	TSP043	TSP650II	TSP650II SK
ESC GS =	o	o	o	o	o	o	o	o	o	o	o	o	o	o
ESC GS t	Spec. A	Spec. A	Spec. A	Spec. A	Spec. A	Spec. A	Spec. A	Spec. A	Spec. A	Spec. A	Spec. B	Spec. B	Spec. B	Spec. B
ESC GS +	x	x	x	x	x	o	o	o	o	o	o	o	o	o
ESCGS#m	Spec. B	Spec. B	Spec. B	Spec. B Ver1.0 to 4.4 Spec.C Ver5.0 or later	Spec. B	Spec. B Ver1.0 to 2.0 Spec.C Ver3.0 or later	Spec. B Ver1.0 to 2.0 Spec.C Ver3.0 or later	Spec. B Ver1.0 to 2.0 Spec.C Ver3.0 or later	Spec. C	Spec. C	Spec. C	Spec. C	Spec. C	Spec. C
ESCRSF	x	x	x	x	o	o	o	o	o	o	o	o	o	o
ESCRSC	x	x	x	x	x	o	o	o	o	o	x	x	o	x
ESCRSL	x	x	x	x	x	Spec. A Ver. 1.3 to Ver. 1.4 Spec. B Ver. 2.0 or later	Spec. A Ver. 1.0 to Ver. 1.4 Spec. B Ver. 2.0 or later	Spec. B	Spec. B	Spec. B	Spec. B	Spec. B	Spec. B	Spec. B
ESCGSETX	x	x	x	x	x	Spec.A Ver. 2.0 or later Spec.B Ver. 3.0 or later	Spec.A Ver. 2.0 or later Spec.B Ver. 3.0 or later	Spec.A Ver. 2.0 or later Spec.B Ver. 3.0 or later	Spec.A Ver. 1.0 Spec.B Ver. 1.1 or later	Spec. B	Spec. B	Spec. B	Spec. B	Spec. B

## • STAR Original Presenter Control Commands

Commands	Model Name													
	TSP700	TSP600	TSP800	TUP900	TSP1000	TSP700II	TSP650	TUP500	TSP800II	FVP10	BSC10	TSP043	TSP650II	TSP650II SK
ESC SYN 0	x	x	x	o	x	x	x	o	x	x	x	x	x	x
ESC SYN 1	x	x	x	o	x	x	x	o	x	x	x	x	x	x
ESC SYN 3	x	x	x	o	x	x	x	o	x	x	x	x	x	x
ESC SYN 4	x	x	x	o	x	x	x	o	x	x	x	x	x	x
ESC GS SUB DC1	x	x	x	x	x	x	x	o	x	x	x	x	x	x
ESC GS SUB DC2	x	x	x	x	x	x	x	o	x	x	x	x	x	x
ESC GS SUB DC3	x	x	x	x	x	x	x	o	x	x	x	x	x	x

## • Star Original Mark Commands

Commands	Model Name													
	TSP700	TSP600	TSP800	TUP900	TSP1000	TSP700II	TSP650	TUP500	TSP800II	FVP10	BSC10	TSP043	TSP650II	TSP650IISK
ESC GS * 0	Ver4.0 or later	X	X	Ver3.0 or later	o	o	o	o	o	o	o	o	o	o
ESC GS * 1	Ver4.0 or later	X	X	Ver3.0 or later	o	o	o	o	o	o	o	o	o	o
ESC GS * 2	Ver4.0 or later	X	X	Ver3.0 or later	o	o	o	o	o	o	o	o	o	o
ESC GS * W	Ver4.0 or later	X	X	Ver3.0 or later	o	o	o	o	o	o	o	o	o	o
ESC GS * C	Ver4.0 or later	X	X	Ver3.0 or later	o	o	o	o	o	o	o	o	o	o

## • STAR Original Auto Logo Commands

Commands	Model Name													
	TSP700	TSP600	TSP800	TUP900	TSP1000	TSP700II	TSP650	TUP500	TSP800II	FVP10	BSC10	TSP043	TSP650II	TSP650IISK
ESCGS/W	Ver4.0 or later	X	X	X	X	o	o	X	o	o	Ver. 1.3 or later	Ver. 1.3 or later	o	o
ESC GS / C	Ver4.0 or later	X	X	X	X	o	o	X	o	o	Ver. 1.3 or later	Ver. 1.3 or later	o	o
ESC GS / 1	Ver4.0 or later	X	X	X	X	o	o	X	o	o	Ver. 1.3 or later	Ver. 1.3 or later	o	o
ESC GS / 2	Ver4.0 or later	X	X	X	X	o	o	X	o	o	Ver. 1.3 or later	Ver. 1.3 or later	o	o
ESC GS / 3	Ver4.0 or later	X	X	X	X	o	o	X	o	o	Ver. 1.3 or later	Ver. 1.3 or later	o	o
ESC GS / 4	Ver4.0 or later	X	X	X	X	o	o	X	o	o	Ver. 1.3 or later	Ver. 1.3 or later	o	o
ESC GS / 5	Ver4.0 or later	X	X	X	X	o	o	X	o	o	Ver. 1.3 or later	Ver. 1.3 or later	o	o
ESC GS / 6	Ver4.0 or later	X	X	X	X	o	o	X	o	o	Ver. 1.3 or later	Ver. 1.3 or later	o	o

## • Star Original User ID Commands

Commands	Model Name													
	TSP700	TSP600	TSP800	TUP900	TSP1000	TSP700II	TSP650	TUP500	TSP800II	FVP10	BSC10	TSP043	TSP650II	TSP650IISK
ESC GS % W	X	X	X	X	o	o	o	o	o	o	o	o	o	o
ESC GS % 0	X	X	X	X	o	o	o	o	o	o	o	o	o	o
ESC GS % 1	X	X	X	X	o	o	o	o	o	o	o	o	o	o
ESC GS % P	X	X	X	X	o	o	o	o	o	o	o	o	o	o

## • Star Original Buzzer Commands

Commands	Model Name													
	TSP700	TSP600	TSP800	TUP900	TSP1000	TSP700II	TSP650	TUP500	TSP800II	FVP10	BSC10	TSP043	TSP650II	TSP650IISK
ESC GS BEL	Ver 5.0 or later	X	X	X	o	o	o	X	o	o	o	o	o	o
ESC GS EM DC1	X	X	X	X	X	Ver 1.3 or later	o	X	o	o	o	o	o	o
ESC GS EM DC2	X	X	X	X	X	Ver 1.3 or later	o	X	o	o	o	o	o	o

• Star Original PDF417 Commands

Commands	Model Name													
	TSP700	TSP600	TSP800	TUP900	TSP1000	TSP700II	TSP650	TUP500	TSP800II	FVP10	BSC10	TSP043	TSP650II	TSP650IISK
ESC GS x S 0	X	X	X	Ver 3.1 or later	○	○	X	○	○	○	X	X	X	X
ESC GS x S 1	X	X	X	Ver 3.1 or later	○	○	X	○	○	○	X	X	X	X
ESC GS x S 2	X	X	X	Ver 3.1 or later	○	○	X	○	○	○	X	X	X	X
ESC GS x S 3	X	X	X	Ver 3.1 or later	○	○	X	○	○	○	X	X	X	X
ESC GS x D	X	X	X	Ver 3.1 or later	○	○	X	○	○	○	X	X	X	X
ESC GS x P	X	X	X	Ver 3.1 or later	○	○	X	○	○	○	X	X	X	X
ESC GS x I	X	X	X	Ver 3.1 or later	○	○ Ver 5.1 or earlier x Ver 6.0 or later	X	○ Ver 4.2 or earlier x Ver 6.0 or later	○ Ver 2.1 or earlier x Ver 6.0 or later	○	X	X	X	X

• Star Original Print Starting Trigger Control Commands

Commands	Model Name													
	TSP700	TSP600	TSP800	TUP900	TSP1000	TSP700II	TSP650	TUP500	TSP800II	FVP10	BSC10	TSP043	TSP650II	TSP650IISK
ESC GS g 0	X	X	X	X	Ver1.1 or later	○	○	○	○	○	○	○	○	○
ESC GS g 1	X	X	X	X	Ver1.1 or later	○	○	○	○	○	○	○	○	○

• Star Original QR Commands

Commands	Model Name													
	TSP700	TSP600	TSP800	TUP900	TSP1000	TSP700II	TSP650	TUP500	TSP800II	FVP10	BSC10	TSP043	TSP650II	TSP650IISK
ESC GS y S 0	X	X	X	X	Ver1.2 or later	○	X	○	○	○	X	X	X	X
ESC GS y S 1	X	X	X	X	Ver1.2 or later	○	X	○	○	○	X	X	X	X
ESC GS y S 2	X	X	X	X	Ver1.2 or later	○	X	○	○	○	X	X	X	X
ESC GS y D 1	X	X	X	X	Ver1.2 or later	○	X	○	○	○	X	X	X	X
ESC GS y D 2	X	X	X	X	Ver1.2 or later	○	X	○	○	○	X	X	X	X
ESC GS y P	X	X	X	X	Ver1.2 or later	○	X	○	○	○	X	X	X	X
ESC GS y I	X	X	X	X	Ver1.2 or later	○ Ver 5.1 or earlier x Ver 6.0 or later	X	○ Ver 4.2 or earlier x Ver 6.0 or later	○ Ver 2.1 or earlier x Ver 6.0 or later	○	X	X	X	X

• Star Original Page Function Commands

Commands	Model Name													
	TSP700	TSP600	TSP800	TUP900	TSP1000	TSP700II	TSP650	TUP500	TSP800II	FVP10	BSC10	TSP043	TSP650II	TSP650IISK
ESC GS h 0	X	X	X	X	X	○	X	○	○	○	○	○	○	○
ESC GS h 1	X	X	X	X	X	○	X	○	○	○	Ver. 1.3 or later	Ver. 1.3 or later	○	○

## • Star Original Reduced Printing Function Command

Commands	Model Name														
	TSP700	TSP600	TSP800	TUP900	TSP1000	TSP700II	TSP650	TUP500	TSP800II	FVP10	BSC10	TSP043	TSP650II	TSP650IIISK	
ESC GS c	X	X	X	X	X	X	X	X	X	○	○	○	○	X	

## • Star Original Text Search Commands

Commands	Model Name														
	TSP700	TSP600	TSP800	TUP900	TSP1000	TSP700II	TSP650	TUP500	TSP800II	FVP10	BSC10	TSP043	TSP650II	TSP650IIISK	
ESC GS ) B (fn = 48)	X	X	X	X	X	X	X	X	X	○	○	○	○	○	
ESC GS ) B (fn = 49)	X	X	X	X	X	X	X	X	X	○	○	○	○	○	
ESC GS ) B (fn = 50)	X	X	X	X	X	X	X	X	X	○	○	○	○	○	
ESC GS ) B (fn = 64)	X	X	X	X	X	X	X	X	X	○	○	○	○	○	
ESC GS ) B (fn = 65)	X	X	X	X	X	X	X	X	X	○	○	○	○	○	
ESC GS ) B (fn = 66)	X	X	X	X	X	X	X	X	X	X	Ver. 1.3 or later	Ver. 1.3 or later	○	○	
ESC GS ) B (fn = 80)	X	X	X	X	X	X	X	X	X	○	○	○	○	○	
ESC GS ) B (fn = 81)	X	X	X	X	X	X	X	X	X	○	○	○	○	○	
ESC GS ) B (fn = 96)	X	X	X	X	X	X	X	X	X	○	○	○	○	○	
ESC GS ) B (fn = 97)	X	X	X	X	X	X	X	X	X	○	○	○	○	○	

## • Star Original Printer Information Transmission Command

Commands	Model Name														
	TSP700	TSP600	TSP800	TUP900	TSP1000	TSP700II	TSP650	TUP500	TSP800II	FVP10	BSC10	TSP043	TSP650II	TSP650IIISK	
ESC GS ) I (fn = 48)	X	X	X	X	X	X	X	X	X	X	Ver. 1.3 or later	Ver. 1.3 or later	○	○	

## • Star Original Individual Logo Command

Commands	Model Name														
	TSP700	TSP600	TSP800	TUP900	TSP1000	TSP700II	TSP650	TUP500	TSP800II	FVP10	BSC10	TSP043	TSP650II	TSP650IIISK	
ESC GS ) L (fn = 48)	X	X	X	X	X	X	X	X	X	X	○	○	○	○	
ESC GS ) L (fn = 49)	X	X	X	X	X	X	X	X	X	X	Ver. 1.3 or later	Ver. 1.3 or later	○	○	
ESC GS ) L (fn = 50)	X	X	X	X	X	X	X	X	X	X	Spec.A Ver. 1.3 or later	Spec.A Ver. 1.3 or later	Spec. B	Spec. B	

## • Star Original Audio Commands

Commands	Model Name														
	TSP700	TSP600	TSP800	TUP900	TSP1000	TSP700II	TSP650	TUP500	TSP800II	FVP10	BSC10	TSP043	TSP650II	TSP650IIISK	
ESC GS s O	X	X	X	X	X	X	X	X	X	○	X	X	X	X	
ESC GS s P	X	X	X	X	X	X	X	X	X	○	X	X	X	X	
ESC GS s R	X	X	X	X	X	X	X	X	X	○	X	X	X	X	
ESC GS s I	X	X	X	X	X	X	X	X	X	○	X	X	X	X	
ESC GS s U	X	X	X	X	X	X	X	X	X	○	X	X	X	X	
ESC GS s T	X	X	X	X	X	X	X	X	X	○	X	X	X	X	

## • Star Original Hold print control Command

Commands	Model Name													
	TSP700	TSP600	TSP800	TUP900	TSP1000	TSP700II	TSP650	TUP500	TSP800II	FVP10	BSC10	TSP043	TSP650II	TSP650IISK
ESC SYN DC3	x	x	x	x	x	x	x	x	x	x	x	x	x	o
ESC SYN DC4	x	x	x	x	x	x	x	x	x	x	x	x	x	o
ESC GS ) s	x	x	x	x	x	x	x	x	x	x	x	x	x	o

## 7-2 Parallel Interface

### • Standard Commands

Commands	Model Name													
	TSP700	TSP600	TSP800	TUP900	TSP1000	TSP700II	TSP650	TUP500	TSP800II	FVP10	BSC10	TSP043	TSP650II	TSP650II SK
HT	○	○	○	○	○	○	○	○	○	○	○	○	○	○
LF	○	○	○	○	○	○	○	○	○	○	○	○	○	○
FF	○	○	○	○	○	○	○	○	○	○	○	○	○	○
CR	○	○	○	○	○	○	○	○	○	○	○	○	○	○
CAN	○	○	○	○	○	○	○	○	○	○	○	○	○	○
DLE EOT	Spec. A	Spec. A	Spec. A	Spec. B	Spec. B	Spec. B-1 Ver. 1.4 or older Spec. B-2 Ver. 2.0 or later	Spec. B-1 Ver. 1.4 or older Spec. B-2 Ver. 2.0 or later	Spec. B-1 Ver. 1.0 or older Spec. B-2 Ver. 2.0 or later	Spec. B-2	Spec. B-2	Spec. B-2	Spec. B-2	Spec. B-2	Spec. B-2
DLE ENQ	X	○	X	X	X	X	X	X	X	X	X	X	X	X
DLE DC4	○	○	○	X	X	○	○	X	○	○	○	○	○	○
ESC FF	○	○	○	○	○	○	○	○	○	○	○	○	○	○
ESC SP	○	○	○	○	○	○	○	○	○	○	○	○	○	○
ESC !	○	○	○	○	○	○	○	○	○	○	○	○	○	○
ESC \$	○	○	○	○	○	○	○	○	○	○	○	○	○	○
ESC %	○	○	○	○	○	○	○	○	○	○	○	○	○	○
ESC &	○	○	○	○	○	○	○	○	○	○	○	○	○	○
ESC *	Spec. A	Spec. A	Spec. A	Spec. A	Spec. A	Spec. A	Spec. A	Spec. A	Spec. A	Spec. A	Spec. A	Spec. A	Spec. B	Spec. B
ESC -	○	○	○	○	○	○	○	○	○	○	○	○	○	○
ESC 2	○	○	○	○	○	○	○	○	○	○	○	○	○	○
ESC 3	○	○	○	○	○	○	○	○	○	○	○	○	○	○
ESC =	○	○	○	X	X	○	○	○	○	○	○	○	○	○
ESC ?	○	○	○	○	○	○	○	○	○	○	○	○	○	○
ESC @	○	○	○	○	○	○	○	○	○	○	○	○	○	○
ESC D	○	○	○	○	○	○	○	○	○	○	○	○	○	○
ESC E	○	○	○	○	○	○	○	○	○	○	○	○	○	○
ESC G	○	○	○	○	○	○	○	○	○	○	○	○	○	○
ESC J	○	○	○	○	○	○	○	○	○	○	○	○	○	○
ESC L	○	○	○	○	○	○	○	○	○	○	○	○	○	○
ESC M	○	○	○	○	○	○	○	○	○	○	○	○	○	○
ESC R	Spec. A	Spec. A	Spec. A	Spec. A	Spec. A	Spec. A	Spec. A	Spec. A	Spec. A	Spec. A	Spec. A Ver. 1.0 to Ver. 1.2 Spec. B Ver. 1.3 or later	Spec. A Ver. 1.0 to Ver. 1.2 Spec. B Ver. 1.3 or later	Spec. B	Spec. B
ESC S	○	○	○	○	○	○	○	○	○	○	○	○	○	○
ESC T	○	○	○	○	○	○	○	○	○	○	○	○	○	○
ESC V	○	○	○	○	○	○	○	○	○	○	○	○	○	○
ESC W	○	○	○	○	○	○	○	○	○	○	○	○	○	○
ESC \	○	○	○	○	○	○	○	○	○	○	○	○	○	○
ESC a	○	○	○	○	○	○	○	○	○	○	○	○	○	○
ESC c 3	Spec. B- $\alpha$ Ver 4.0 or later	Spec. B- $\alpha$ Ver 4.0 or later	Spec. B- $\alpha$ Ver 5.0 or later	Spec. B- $\beta$	Spec. B- $\beta$	Spec. B- $\alpha$	Spec. B- $\alpha$	Spec. B- $\beta$	Spec. B- $\alpha$	Spec. B- $\alpha$	Spec. B- $\alpha$	Spec. B- $\alpha$	Spec. B- $\alpha$	Spec. B- $\alpha$
ESC c 4	○	○	○	○	○	○	○	○	○	○	○	○	○	○
ESC c 5	○	○	○	○	○	○	○	○	○	○	○	○	○	○
ESC d	○	○	○	○	○	○	○	○	○	○	○	○	○	○
ESC p	○	○	○	X	X	○	○	X	○	○	○	○	○	○
ESC t	Spec. A	Spec. A	Spec. A	Spec. A	Spec. A	Spec. A	Spec. A	Spec. A	Spec. A	Spec. A	Spec. B	Spec. B	Spec. B	Spec. B



Commands	Model Name													
	TSP700	TSP600	TSP800	TUP900	TSP1000	TSP700II	TSP650	TUP500	TSP800II	FVP10	BSC10	TSP043	TSP650II	TSP650II SK
ESC {	o	o	o	o	o	o	o	o	o	o	o	o	o	o
FS g 1	x	x	x	x	x	x	x	x	x	x	x	x	x	x
FS g 2	x	x	x	x	x	x	x	x	x	x	x	x	x	x
FS p	o	o	o	o	o	o	o	o	o	o	o	o	o	o
FS q	o	o	o	o	o	o	o	o	o	o	o	o	o	o
GS !	o	o	o	o	o	o	o	o	o	o	o	o	o	o
GS \$	o	o	o	o	o	o	o	o	o	o	o	o	o	o
GS *	o	o	o	o	o	o	o	o	o	o	o	o	o	o
GS (A	o	o	o	o	o	o	o	o	o	o	o	o	o	o
GS ( K (fn=49)	x	x	x	Spec. A	Spec. A	Spec. A	Spec. A	Spec. A	Spec. B	Spec. B	Spec. C	Spec. C	Spec. C	X
GS ( K (fn=50)	x	x	x	X	X	X	X	X	X	X	Spec. A	Spec. A	Spec. A	Spec. B
GS ( L (fn=48)	x	x	x	X	X	X	X	X	X	X	o	o	o	o
GS ( L (fn=51)	x	x	x	X	X	X	X	X	X	X	o	o	o	o
GS ( L (fn=64)	x	x	x	X	X	X	X	X	X	X	o	o	o	o
GS ( L (fn=65)	x	x	x	X	X	X	X	X	X	X	o	o	o	o
GS ( L (fn=66)	x	x	x	X	X	X	X	X	X	X	o	o	o	o
GS ( L (fn=67)	x	x	x	X	X	X	X	X	X	X	o	o	o	o
GS ( L (fn=69)	x	x	x	X	X	X	X	X	X	X	o	o	o	o
GS ( L (fn=112)	x	x	x	X	X	Ver.2.0 or later	Ver.2.0 or later	o	o	o	o	o	o	o
GS 8 L (fn=48)	x	x	x	X	X	X	X	X	X	X	o	o	o	o
GS 8 L (fn=51)	x	x	x	X	X	X	X	X	X	X	o	o	o	o
GS 8 L (fn=64)	x	x	x	X	X	X	X	X	X	X	o	o	o	o
GS 8 L (fn=65)	x	x	x	X	X	X	X	X	X	X	o	o	o	o
GS 8 L (fn=66)	x	x	x	X	X	X	X	X	X	X	o	o	o	o
GS 8 L (fn=67)	x	x	x	X	X	X	X	X	X	X	o	o	o	o
GS 8 L (fn=69)	x	x	x	X	X	X	X	X	X	X	o	o	o	o
GS 8 L (fn=112)	x	x	x	X	X	Ver.2.0 or later	Ver.2.0 or later	o	o	o	o	o	o	o
GS ( N	x	x	x	o	o	o	o	o	o	o	o	o	o	o
GS ( k (cn=48,fn=65)	x	x	x	X	X	X	X	X	X	X	o	o	o	o
GS ( k (cn=48,fn=66)	x	x	x	X	X	X	X	X	X	X	o	o	o	o
GS ( k (cn=48,fn=67)	x	x	x	X	X	X	X	X	X	X	o	o	o	o
GS ( k (cn=48,fn=68)	x	x	x	X	X	X	X	X	X	X	o	o	o	o
GS ( k (cn=48,fn=69)	x	x	x	X	X	X	X	X	X	X	o	o	o	o
GS ( k (cn=48,fn=70)	x	x	x	X	X	X	X	X	X	X	o	o	o	o
GS ( k (cn=48,fn=80)	x	x	x	X	X	X	X	X	X	X	o	o	o	o
GS ( k (cn=48,fn=81)	x	x	x	X	X	X	X	X	X	X	o	o	o	o
GS ( k (cn=48,fn=82)	x	x	x	X	X	X	X	X	X	X	Ver. 1.8 or older x Ver.1.9 or later	o	Ver. 1.2 or older x Ver.2.0 or later	X
GS ( k (cn=49,fn=65)	x	x	x	X	X	X	X	X	X	X	o	o	o	o
GS ( k (cn=49,fn=67)	x	x	x	X	X	X	X	X	X	X	o	o	o	o
GS ( k (cn=49,fn=69)	x	x	x	X	X	X	X	X	X	X	o	o	o	o
GS ( k (cn=49,fn=80)	x	x	x	X	X	X	X	X	X	X	o	o	o	o
GS ( k (cn=49,fn=81)	x	x	x	X	X	X	X	X	X	X	o	o	o	o
GS ( k (cn=49,fn=82)	x	x	x	X	X	X	X	X	X	X	Ver. 1.8 or older x Ver.1.9 or later	o	Ver. 1.2 or older x Ver.2.0 or later	X
<b>Commands</b>	<b>Model Name</b>													

	TSP700	TSP600	TSP800	TUP900	TSP1000	TSP700II	TSP650	TUP500	TSP800II	FVP10	BSC10	TSP043	TSP650II	TSP650IIISK
GS ( k (cn=51,fn=67)	X	X	X	X	X	X	X	X	X	X	X	X	Ver.2.0 or later	Ver.2.0 or later
GS ( k (cn=51,fn=71)	X	X	X	X	X	X	X	X	X	X	X	X	Ver.2.0 or later	Ver.2.0 or later
GS ( k (cn=51,fn=80)	X	X	X	X	X	X	X	X	X	X	X	X	Ver.2.0 or later	Ver.2.0 or later
GS ( k (cn=51,fn=81)	X	X	X	X	X	X	X	X	X	X	X	X	Ver.2.0 or later	Ver.2.0 or later
GS ( k (cn=52,fn=67)	X	X	X	X	X	X	X	X	X	X	X	X	Ver.2.0 or later	Ver.2.0 or later
GS ( k (cn=52,fn=71)	X	X	X	X	X	X	X	X	X	X	X	X	Ver.2.0 or later	Ver.2.0 or later
GS ( k (cn=52,fn=72)	X	X	X	X	X	X	X	X	X	X	X	X	Ver.2.0 or later	Ver.2.0 or later
GS ( k (cn=52,fn=80)	X	X	X	X	X	X	X	X	X	X	X	X	Ver.2.0 or later	Ver.2.0 or later
GS ( k (cn=52,fn=81)	X	X	X	X	X	X	X	X	X	X	X	X	Ver.2.0 or later	Ver.2.0 or later
GS /	o	o	o	o	o	o	o	o	o	o	o	o	o	o
GS :	o	o	o	o	o	o	o	o	o	o	o	o	o	o
GS B	o	o	o	o	o	o	o	o	o	o	o	o	o	o
GS C 0	X	X	X	o	o	o	o	o	o	o	X	X	o	o
GS C 1	X	X	X	o	o	o	o	o	o	o	X	X	o	o
GS C 2	X	X	X	o	o	o	o	o	o	o	X	X	o	o
GS C :	X	X	X	o	o	o	o	o	o	o	X	X	o	o
GS E	X	X	X	Spec. A	Spec. A	Spec. A	Spec. A	Spec. A	Spec. A	Spec. A	X	X	Spec. A	Spec. B
GS H	o	o	o	o	o	o	o	o	o	o	o	o	o	o
GS I	Spec. A	Spec. A	Spec. A	Spec. A Ver. 4.4 or older Spec. B Ver. 4.5 or later	Spec. A	Spec. A Ver. 3.0 or older Spec. B Ver. 3.1 or later	Spec. A Ver. 3.0 or older Spec. B Ver. 3.1 or later	Spec. A Ver. 3.1 or older Spec. B Ver. 3.2 or later	Spec. A	Spec. B	Spec. B	Spec. B	Spec. B	Spec. B
GS L	o	o	o	o	o	o	o	o	o	o	o	o	o	o
GS P	o	o	o	X	X	o	o	X	o	o	o	o	o	o
GS T	X	X	X	o	o	o	o	o	o	o	o	o	o	o
GS V	o	o	o	o	o	o	o	o	o	o	o	o	o	o
GS W	o	o	o	o	o	o	o	o	o	o	o	o	o	o
GS \	o	o	o	o	o	o	o	o	o	o	o	o	o	o
GS ^	o	o	o	o	o	o	o	o	o	o	o	o	o	o
GS b	X	X	X	X	X	X	X	X	X	X	Ver. 1.3 or later	Ver. 1.3 or later	o	o
GS c	X	X	X	o	o	o	o	o	o	o	X	X	o	o
GS f	o	o	o	o	o	o	o	o	o	o	o	o	o	o
GS h	o	o	o	o	o	o	o	o	o	o	o	o	o	o
GS k	Spec. A Spec. B	Spec. A Spec. B	Spec. A Spec. B	Spec. A Spec. B	Spec. A Spec. B	Spec. A Spec. B	Spec. A Spec. B	Spec. A Spec. B	Spec. A Spec. B	Spec. A Spec. B	Spec. A Spec. B	Spec. A Spec. B	Spec. A,B: Ver. 1.2 or older Spec. A,B,C: Ver.2.0 or later	Spec. A Spec. B Spec. C
GS r	o	o	o	o	o	o	o	o	o	o	o	o	o	o
GS v 0	o	o	o	o	o	o	o	o	o	o	o	o	o	o
GS w	o	o	o	o	o	o	o	o	o	o	o	o	o	o

• Kanji Control Commands (DBCS Settings, Kanji Specifications Only)

Commands	Model Name													
	TSP700	TSP600	TSP800	TUP900	TSP1000	TSP700II	TSP650	TUP500	TSP800II	FVP10	BSC10	TSP043	TSP650II	TSP650IISK
FS !	○	○	○	○	○	○	○	○	○	○	○	○	○	○
FS &	Spec. A	Spec. A	Spec. A	Spec. A	Spec. A	Spec. A	Spec. A	Spec. A	Spec. A	Spec. A	Spec. B	Spec.B	Spec.A	Spec.A
FS -	○	○	○	○	○	○	○	○	○	○	○	○	○	○
FS .	○	○	○	○	○	○	○	○	○	○	○	○	○	○
FS 2	○	○	○	○	○	○	○	○	○	○	○	○	○	○
FS C	○	○	○	○	○	○	○	○	○	○	X	X	○	○
FS S	○	○	○	○	○	○	○	○	○	○	○	○	○	○
FS W	○	○	○	○	○	○	○	○	○	○	○	○	○	○

• ESC/POS Black Mark Related Commands (When black marks are effective)

Commands	Model Name													
	TSP700	TSP600	TSP800	TUP900	TSP1000	TSP700II	TSP650	TUP500	TSP800II	FVP10	BSC10	TSP043	TSP650II	TSP650IISK
FF	○	○	○	○	○	○	X	○	○	○	○	○	X	X
DLE ENQ	○	○	○	○	○	○	X	○	○	○	○	○	X	X
GS FF	X	X	X	○	○	○	X	○	○	○	○	○	X	X
GS ( F	X	X	X	○	○	X	X	X	X	X	X	X	X	X
GS ( M n=1	X	X	X	○	○	X	X	X	X	X	X	X	X	X
GS ( M n=2	X	X	X	○	○	X	X	X	X	X	X	X	X	X
GS ( M n=3	X	X	X	○	○	X	X	X	X	X	X	X	X	X
GS <	○	○	○	X	X	○	X	X	○	○	○	○	X	X
GS V	○	○	○	○	○	○	X	○	○	○	○	○	X	X

• STAR Original Commands

Commands	Model Name													
	TSP700	TSP600	TSP800	TUP900	TSP1000	TSP700II	TSP650	TUP500	TSP800II	FVP10	BSC10	TSP043	TSP650II	TSP650II SK
ESC GS =	o	o	o	o	o	o	o	o	o	o	o	o	o	o
ESC GS t	Spec. A	Spec. A	Spec. A	Spec. A	Spec. A	Spec. A	Spec. A	Spec. A	Spec. A	Spec. A	Spec. B	Spec. B	Spec. B	Spec. B
ESC GS +	x	x	x	x	x	o	o	o	o	o	o	o	o	o
ESCGS#m	Spec. B	Spec. B	Spec. B	Spec. B Ver1.0 to 4.4 Spec.C Ver.5.0 or later	Spec. B	Spec. B Ver1.0 to 2.0 Spec.C Ver.3.0 or later	Spec. B Ver1.0 to 2.0 Spec.C Ver.3.0 or later	Spec. B Ver1.0 to 2.0 Spec.C Ver.3.0 or later	Spec. C	Spec. C	Spec. C	Spec. C	Spec. C	Spec. C
ESCRSF	x	x	x	x	o	o	o	o	o	o	o	o	o	o
ESCRSC	x	x	x	x	x	o	o	o	o	o	x	x	o	x
ESCRSL	x	x	x	x	x	Spec. A Ver. 1.3 ~1.4 Spec. B Ver. 2.0 or later	Spec. A Ver. 1.0 ~1.4 Spec. B Ver. 2.0 or later	Spec. B	Spec. B	Spec. B	Spec. B	Spec. B	Spec. B	Spec. B
ESCGSETX	x	x	x	x	x	Spec. A Ver. 2.0 or older Spec. B Ver. 3.0 or later	Spec. A Ver. 2.0 or older Spec. B Ver. 3.0 or later	Spec. A Ver. 2.0 or older Spec. B Ver. 3.0 or later	Spec. A Ver. 1.0 Spec. B Ver. 1.1 or later	Spec. B	Spec. B	Spec. B	Spec. B	Spec. B

• STAR Original Presenter Control Commands

Commands	Model Name													
	TSP700	TSP600	TSP800	TUP900	TSP1000	TSP700II	TSP650	TUP500	TSP800II	FVP10	BSC10	TSP043	TSP650II	TSP650II SK
ESC SYN 0	x	x	x	o	x	x	x	o	x	x	x	x	x	x
ESC SYN 1	x	x	x	o	x	x	x	o	x	x	x	x	x	x
ESC SYN 3	x	x	x	o	x	x	x	o	x	x	x	x	x	x
ESC SYN 4	x	x	x	o	x	x	x	o	x	x	x	x	x	x
ESC GS SUB DC1	x	x	x	x	x	x	x	o	x	x	x	x	x	x
ESC GS SUB DC2	x	x	x	x	x	x	x	o	x	x	x	x	x	x
ESC GS SUB DC3	x	x	x	x	x	x	x	o	x	x	x	x	x	x

• Star Original Mark Commands

Commands	Model Name													
	TSP700	TSP600	TSP800	TUP900	TSP1000	TSP700II	TSP650	TUP500	TSP800II	FVP10	BSC10	TSP043	TSP650II	TSP650IISK
ESC GS * 0	Ver4.0 or later	X	X	Ver3.0 or later	o	o	o	o	o	o	o	o	o	o
ESC GS * 1	Ver4.0 or later	X	X	Ver3.0 or later	o	o	o	o	o	o	o	o	o	o
ESC GS * 2	Ver4.0 or later	X	X	Ver3.0 or later	o	o	o	o	o	o	o	o	o	o
ESCGS*W	Ver4.0 or later	X	X	Ver3.0 or later	o	o	o	o	o	o	o	o	o	o
ESC GS * C	Ver4.0 or later	X	X	Ver3.0 or later	o	o	o	o	o	o	o	o	o	o

• STAR Original Auto Logo Commands

Commands	Model Name													
	TSP700	TSP600	TSP800	TUP900	TSP1000	TSP700II	TSP650	TUP500	TSP800II	FVP10	BSC10	TSP043	TSP650II	TSP650IISK
ESCGS / W	Ver4.0 or later	X	X	X	X	o	o	X	o	o	Ver. 1.3 or older	Ver. 1.3 or older	o	o
ESC GS / C	Ver4.0 or later	X	X	X	X	o	o	X	o	o	Ver. 1.3 or older	Ver. 1.3 or older	o	o
ESC GS / 1	Ver4.0 or later	X	X	X	X	o	o	X	o	o	Ver. 1.3 or older	Ver. 1.3 or older	o	o
ESC GS / 2	Ver4.0 or later	X	X	X	X	o	o	X	o	o	Ver. 1.3 or older	Ver. 1.3 or older	o	o
ESC GS / 3	Ver4.0 or later	X	X	X	X	o	o	X	o	o	Ver. 1.3 or older	Ver. 1.3 or older	o	o
ESC GS / 4	Ver4.0 or later	X	X	X	X	o	o	X	o	o	Ver. 1.3 or older	Ver. 1.3 or older	o	o
ESC GS / 5	Ver4.0 or later	X	X	X	X	o	o	X	o	o	Ver. 1.3 or older	Ver. 1.3 or older	o	o
ESC GS / 6	Ver4.0 or later	X	X	X	X	o	o	X	o	o	Ver. 1.3 or older	Ver. 1.3 or older	o	o

• Star Original Buzzer Commands

Commands	Model Name													
	TSP700	TSP600	TSP800	TUP900	TSP1000	TSP700II	TSP650	TUP500	TSP800II	FVP10	BSC10	TSP043	TSP650II	TSP650IISK
ESC GS BEL	Ver5.0 or later	X	X	X	o	o	o	X	o	o	o	o	o	o
ESC GS EM DC1	X	X	X	X	X	Ver1.3 or later	o	X	o	o	o	o	o	o
ESC GS EM DC2	X	X	X	X	X	Ver1.3 or later	o	X	o	o	o	o	o	o



• Star Original PDF417 Commands

Commands	Model Name													
	TSP700	TSP600	TSP800	TUP900	TSP1000	TSP700II	TSP650	TUP500	TSP800II	FVP10	BSC10	TSP043	TSP650II	TSP650IISK
ESC GS x S 0	X	X	X	Ver3.1 or later	o	o	X	o	o	o	X	X	X	X
ESC GS x S 1	X	X	X	Ver3.1 or later	o	o	X	o	o	o	X	X	X	X
ESC GS x S 2	X	X	X	Ver3.1 or later	o	o	X	o	o	o	X	X	X	X
ESC GS x S 3	X	X	X	Ver3.1 or later	o	o	X	o	o	o	X	X	X	X
ESC GS x D	X	X	X	Ver3.1 or later	o	o	X	o	o	o	X	X	X	X
ESC GS x P	X	X	X	Ver3.1 or later	o	o	X	o	o	o	X	X	X	X
ESC GS x I	X	X	X	o Ver 3.1 or later	o	o Ver 5.1 or earlier x Ver 6.0 or later	X	o Ver 4.2 or earlier x Ver 6.0 or later	o Ver 2.1 or earlier x Ver 6.0 or later	o	X	X	X	X

• Star Original Print Starting Trigger Control Commands

Commands	Model Name													
	TSP700	TSP600	TSP800	TUP900	TSP1000	TSP700II	TSP650	TUP500	TSP800II	FVP10	BSC10	TSP043	TSP650II	TSP650IISK
ESC GS g 0	X	X	X	X	Ver1.1 or later	o	o	o	o	o	o	o	o	o
ESC GS g 1	X	X	X	X	Ver1.1 or later	o	o	o	o	o	o	o	o	o

• Star Original QR Commands

Commands	Model Name													
	TSP700	TSP600	TSP800	TUP900	TSP1000	TSP700II	TSP650	TUP500	TSP800II	FVP10	BSC10	TSP043	TSP650II	TSP650IISK
ESC GS y S 0	X	X	X	X	Ver1.2 or later	o	X	o	o	o	X	X	X	X
ESC GS y S 1	X	X	X	X	Ver1.2 or later	o	X	o	o	o	X	X	X	X
ESC GS y S 2	X	X	X	X	Ver1.2 or later	o	X	o	o	o	X	X	X	X
ESC GS y D 1	X	X	X	X	Ver1.2 or later	o	X	o	o	o	X	X	X	X
ESC GS y D 2	X	X	X	X	Ver1.2 or later	o	X	o	o	o	X	X	X	X
ESC GS y P	X	X	X	X	Ver1.2 or later	o	X	o	o	o	X	X	X	X
ESC GS y I	X	X	X	X	Ver1.2 or later	o Ver 5.1 or earlier x Ver 6.0 or later	X	o Ver 4.2 or earlier x Ver 6.0 or later	o Ver 2.1 or earlier x Ver 6.0 or later	o	X	X	X	X

• Star Original Page Function Commands

Commands	Model Name													
	TSP700	TSP600	TSP800	TUP900	TSP1000	TSP700II	TSP650	TUP500	TSP800II	FVP10	BSC10	TSP043	TSP650II	TSP650IISK
ESC GS h 0	X	X	X	X	X	○	X	○	○	○	○	○	○	○
ESC GS h 1	X	X	X	X	X	○	X	○	○	○	Ver. 1.3 or later	Ver. 1.3 or later	○	○

• Star Original Reduced Printing Function Command

Commands	Model Name													
	TSP700	TSP600	TSP800	TUP900	TSP1000	TSP700II	TSP650	TUP500	TSP800II	FVP10	BSC10	TSP043	TSP650II	TSP650IISK
ESC GS c	X	X	X	X	X	X	X	X	X	○	○	○	○	X

• Star Original Text Search Commands

Commands	Model Name													
	TSP700	TSP600	TSP800	TUP900	TSP1000	TSP700II	TSP650	TUP500	TSP800II	FVP10	BSC10	TSP043	TSP650II	TSP650IISK
ESC GS ) B (fn = 48)	x	x	x	x	x	x	x	x	x	○	○	○	○	○
ESC GS ) B (fn = 49)	x	x	x	x	x	x	x	x	x	○	○	○	○	○
ESC GS ) B (fn = 50)	x	x	x	x	x	x	x	x	x	○	○	○	○	○
ESC GS ) B (fn = 64)	x	x	x	x	x	x	x	x	x	○	○	○	○	○
ESC GS ) B (fn = 65)	x	x	x	x	x	x	x	x	x	○	○	○	○	○
ESC GS ) B (fn = 66)	x	x	x	x	x	x	x	x	x	x	Ver. 1.3 or later	Ver. 1.3 or later	○	○
ESC GS ) B (fn = 80)	x	x	x	x	x	x	x	x	x	○	○	○	○	○
ESC GS ) B (fn = 81)	x	x	x	x	x	x	x	x	x	○	○	○	○	○
ESC GS ) B (fn = 96)	x	x	x	x	x	x	x	x	x	○	○	○	○	○
ESC GS ) B (fn = 97)	x	x	x	x	x	x	x	x	x	○	○	○	○	○

• Star Original Printer Information Transmission Command

Commands	Model Name													
	TSP700	TSP600	TSP800	TUP900	TSP1000	TSP700II	TSP650	TUP500	TSP800II	FVP10	BSC10	TSP043	TSP650II	TSP650IISK
ESC GS ) I (fn = 48)	X	X	X	X	X	X	X	X	X	X	Ver. 1.3 or later	Ver. 1.3 or later	○	○

• Star Original Individual Logo Command

Commands	Model Name													
	TSP700	TSP600	TSP800	TUP900	TSP1000	TSP700II	TSP650	TUP500	TSP800II	FVP10	BSC10	TSP043	TSP650II	TSP650IISK
ESC GS ) L (fn = 48)	x	x	x	x	x	x	x	x	x	x	○	○	○	○
ESC GS ) L (fn = 49)	x	x	x	x	x	x	x	x	x	x	Ver. 1.3 or later	Ver. 1.3 or later	○	○
ESC GS ) L (fn = 50)	x	x	x	x	x	x	x	x	x	x	Spec. A Ver. 1.3 or later	Spec. A Ver. 1.3 or later	Spec. B	Spec. B



• Star Original Audio Commands

Commands	Model Name													
	TSP700	TSP600	TSP800	TUP900	TSP1000	TSP700II	TSP650	TUP500	TSP800II	FVP10	BSC10	TSP043	TSP650II	TSP650IISK
ESC GS s O	X	X	X	X	X	X	X	X	X	○	X	X	X	X
ESC GS s P	X	X	X	X	X	X	X	X	X	○	X	X	X	X
ESC GS s R	X	X	X	X	X	X	X	X	X	○	X	X	X	X
ESC GS s I	X	X	X	X	X	X	X	X	X	○	X	X	X	X
ESC GS s U	X	X	X	X	X	X	X	X	X	○	X	X	X	X
ESC GS s T	X	X	X	X	X	X	X	X	X	○	X	X	X	X

• Star Original Hold print control Command

Commands	Model Name													
	TSP700	TSP600	TSP800	TUP900	TSP1000	TSP700II	TSP650	TUP500	TSP800II	FVP10	BSC10	TSP043	TSP650II	TSP650IISK
ESC SYN DC3	X	X	X	X	X	X	X	X	X	X	X	X	X	○
ESC SYN DC4	X	X	X	X	X	X	X	X	X	X	X	X	X	○
ESC GS )s	X	X	X	X	X	X	X	X	X	X	X	X	X	○



### 7-3 USB I/F (Ver 1.0) • Ethernet I/F (Silex 1.0)

#### • Standard Commands

Commands	Model Name													
	TSP700	TSP600	TSP800	TUP900	TSP1000	TSP700II	TSP650	TSP650	TSP800II	FVP10	BSC10	TSP043	TSP650II	TSP650IIISK
HT	X	X	X	○	X	X	X	X	X	X	X	X	X	X
LF	X	X	X	○	X	X	X	X	X	X	X	X	X	X
FF	X	X	X	○	X	X	X	X	X	X	X	X	X	X
CR	X	X	X	○	X	X	X	X	X	X	X	X	X	X
CAN	X	X	X	○	X	X	X	X	X	X	X	X	X	X
DLE EOT	X	X	X	X	X	X	X	X	X	X	X	X	X	X
DLE ENQ	X	X	X	X	X	X	X	X	X	X	X	X	X	X
DLE DC4	X	X	X	X	X	X	X	X	X	X	X	X	X	X
ESC FF	X	X	X	○	X	X	X	X	X	X	X	X	X	X
ESC SP	X	X	X	○	X	X	X	X	X	X	X	X	X	X
ESC !	X	X	X	○	X	X	X	X	X	X	X	X	X	X
ESC \$	X	X	X	○	X	X	X	X	X	X	X	X	X	X
ESC %	X	X	X	○	X	X	X	X	X	X	X	X	X	X
ESC &	X	X	X	○	X	X	X	X	X	X	X	X	X	X
ESC *	X	X	X	Spec. A	X	X	X	X	X	X	X	X	X	X
ESC -	X	X	X	○	X	X	X	X	X	X	X	X	X	X
ESC 2	X	X	X	○	X	X	X	X	X	X	X	X	X	X
ESC 3	X	X	X	○	X	X	X	X	X	X	X	X	X	X
ESC =	X	X	X	X	X	X	X	X	X	X	X	X	X	X
ESC ?	X	X	X	○	X	X	X	X	X	X	X	X	X	X
ESC @	X	X	X	○	X	X	X	X	X	X	X	X	X	X
ESC D	X	X	X	○	X	X	X	X	X	X	X	X	X	X
ESC E	X	X	X	○	X	X	X	X	X	X	X	X	X	X
ESC G	X	X	X	○	X	X	X	X	X	X	X	X	X	X
ESC J	X	X	X	○	X	X	X	X	X	X	X	X	X	X
ESC L	X	X	X	○	X	X	X	X	X	X	X	X	X	X
ESC M	X	X	X	○	X	X	X	X	X	X	X	X	X	X
ESC R	X	X	X	Spec. A	X	X	X	X	X	X	X	X	X	X
ESC S	X	X	X	○	X	X	X	X	X	X	X	X	X	X
ESC T	X	X	X	○	X	X	X	X	X	X	X	X	X	X
ESC V	X	X	X	○	X	X	X	X	X	X	X	X	X	X
ESC W	X	X	X	○	X	X	X	X	X	X	X	X	X	X
ESC \	X	X	X	○	X	X	X	X	X	X	X	X	X	X
ESC a	X	X	X	○	X	X	X	X	X	X	X	X	X	X
ESC c 3	X	X	X	X	X	X	X	X	X	X	X	X	X	X
ESC c 4	X	X	X	○	X	X	X	X	X	X	X	X	X	X
ESC c 5	X	X	X	○	X	X	X	X	X	X	X	X	X	X
ESC d	X	X	X	○	X	X	X	X	X	X	X	X	X	X
ESC p	X	X	X	X	X	X	X	X	X	X	X	X	X	X
ESC t	X	X	X	Spec. A	X	X	X	X	X	X	X	X	X	X
ESC {	X	X	X	○	X	X	X	X	X	X	X	X	X	X
FS g 1	X	X	X	X	X	X	X	X	X	X	X	X	X	X
FS g 2	X	X	X	X	X	X	X	X	X	X	X	X	X	X
FS p	X	X	X	○	X	X	X	X	X	X	X	X	X	X
FS q	X	X	X	○ (*)	X	X	X	X	X	X	X	X	X	X
GS !	X	X	X	○	X	X	X	X	X	X	X	X	X	X
GS \$	X	X	X	○	X	X	X	X	X	X	X	X	X	X

Commands	Model Name													
	TSP700	TSP600	TSP800	TUP900	TSP1000	TSP700II	TSP650	TSP650	TSP800II	FVP10	BSC10	TSP043	TSP650II	TSP650IIISK
GS *	X	X	X	○	X	X	X	X	X	X	X	X	X	X
GS ( A	X	X	X	○	X	X	X	X	X	X	X	X	X	X
GS ( K (fn=49)	X	X	X	Spec. A	X	X	X	X	X	X	X	X	X	X
GS ( K (fn=50)	X	X	X	X	X	X	X	X	X	X	X	X	X	X
GS ( L (fn=48)	X	X	X	X	X	X	X	X	X	X	X	X	X	X
GS ( L (fn=51)	X	X	X	X	X	X	X	X	X	X	X	X	X	X
GS ( L (fn=64)	X	X	X	X	X	X	X	X	X	X	X	X	X	X
GS ( L (fn=65)	X	X	X	X	X	X	X	X	X	X	X	X	X	X
GS ( L (fn=66)	X	X	X	X	X	X	X	X	X	X	X	X	X	X
GS ( L (fn=67)	X	X	X	X	X	X	X	X	X	X	X	X	X	X
GS ( L (fn=69)	X	X	X	X	X	X	X	X	X	X	X	X	X	X
GS ( L (fn=112)	X	X	X	X	X	X	X	X	X	X	X	X	X	X
GS 8 L (fn=48)	X	X	X	X	X	X	X	X	X	X	X	X	X	X
GS 8 L (fn=51)	X	X	X	X	X	X	X	X	X	X	X	X	X	X
GS 8 L (fn=64)	X	X	X	X	X	X	X	X	X	X	X	X	X	X
GS 8 L (fn=65)	X	X	X	X	X	X	X	X	X	X	X	X	X	X
GS 8 L (fn=66)	X	X	X	X	X	X	X	X	X	X	X	X	X	X
GS 8 L (fn=67)	X	X	X	X	X	X	X	X	X	X	X	X	X	X
GS 8 L (fn=69)	X	X	X	X	X	X	X	X	X	X	X	X	X	X
GS 8 L (fn=112)	X	X	X	X	X	X	X	X	X	X	X	X	X	X
GS ( N	X	X	X	○	X	X	X	X	X	X	X	X	X	X
GS ( k (cn=48,fn=65)	X	X	X	X	X	X	X	X	X	X	X	X	X	X
GS ( k (cn=48,fn=66)	X	X	X	X	X	X	X	X	X	X	X	X	X	X
GS ( k (cn=48,fn=67)	X	X	X	X	X	X	X	X	X	X	X	X	X	X
GS ( k (cn=48,fn=68)	X	X	X	X	X	X	X	X	X	X	X	X	X	X
GS ( k (cn=48,fn=69)	X	X	X	X	X	X	X	X	X	X	X	X	X	X
GS ( k (cn=48,fn=70)	X	X	X	X	X	X	X	X	X	X	X	X	X	X
GS ( k (cn=48,fn=80)	X	X	X	X	X	X	X	X	X	X	X	X	X	X
GS ( k (cn=48,fn=81)	X	X	X	X	X	X	X	X	X	X	X	X	X	X
GS ( k (cn=48,fn=82)	X	X	X	X	X	X	X	X	X	X	X	X	X	X
GS ( k (cn=49,fn=65)	X	X	X	X	X	X	X	X	X	X	X	X	X	X
GS ( k (cn=49,fn=67)	X	X	X	X	X	X	X	X	X	X	X	X	X	X
GS ( k (cn=49,fn=69)	X	X	X	X	X	X	X	X	X	X	X	X	X	X
GS ( k (cn=49,fn=80)	X	X	X	X	X	X	X	X	X	X	X	X	X	X
GS ( k (cn=49,fn=81)	X	X	X	X	X	X	X	X	X	X	X	X	X	X
GS ( k (cn=49,fn=82)	X	X	X	X	X	X	X	X	X	X	X	X	X	X
GS ( k (cn=51,fn=67)	X	X	X	X	X	X	X	X	X	X	X	X	X	X
GS ( k (cn=51,fn=71)	X	X	X	X	X	X	X	X	X	X	X	X	X	X
GS ( k (cn=51,fn=80)	X	X	X	X	X	X	X	X	X	X	X	X	X	X
GS ( k (cn=51,fn=81)	X	X	X	X	X	X	X	X	X	X	X	X	X	X
GS ( k (cn=52,fn=67)	X	X	X	X	X	X	X	X	X	X	X	X	X	X
GS ( k (cn=52,fn=71)	X	X	X	X	X	X	X	X	X	X	X	X	X	X
GS ( k (cn=52,fn=72)	X	X	X	X	X	X	X	X	X	X	X	X	X	X
GS ( k (cn=52,fn=80)	X	X	X	X	X	X	X	X	X	X	X	X	X	X
GS ( k (cn=52,fn=81)	X	X	X	X	X	X	X	X	X	X	X	X	X	X
GS /	X	X	X	○	X	X	X	X	X	X	X	X	X	X
GS :	X	X	X	○	X	X	X	X	X	X	X	X	X	X
GS B	X	X	X	○	X	X	X	X	X	X	X	X	X	X
GS C 0	X	X	X	○	X	X	X	X	X	X	X	X	X	X
GS C 1	X	X	X	○	X	X	X	X	X	X	X	X	X	X
GS C 2	X	X	X	○	X	X	X	X	X	X	X	X	X	X

Commands	Model Name													
	TSP700	TSP600	TSP800	TUP900	TSP1000	TSP700II	TSP650	TSP650	TSP800II	FVP10	BSC10	TSP043	TSP650II	TSP650II SK
GS C ;	X	X	X	○	X	X	X	X	X	X	X	X	X	X
GS E	X	X	X	Spec. A	X	X	X	X	X	X	X	X	X	X
GS H	X	X	X	○	X	X	X	X	X	X	X	X	X	X
GS I	X	X	X	Spec. A Ver. 4.4 or older Spec. B Ver. 4.5 or later	X	X	X	X	X	X	X	X	X	X
GS L	X	X	X	○	X	X	X	X	X	X	X	X	X	X
GS P	X	X	X	X	X	X	X	X	X	X	X	X	X	X
GS T	X	X	X	○	X	X	X	X	X	X	X	X	X	X
GS V	X	X	X	○	X	X	X	X	X	X	X	X	X	X
GS W	X	X	X	○	X	X	X	X	X	X	X	X	X	X
GS \	X	X	X	○	X	X	X	X	X	X	X	X	X	X
GS ^	X	X	X	○	X	X	X	X	X	X	X	X	X	X
GS b	X	X	X	X	X	X	X	X	X	X	X	X	X	X
GS c	X	X	X	○	X	X	X	X	X	X	X	X	X	X
GS f	X	X	X	○	X	X	X	X	X	X	X	X	X	X
GS h	X	X	X	○	X	X	X	X	X	X	X	X	X	X
GS k	X	X	X	Spec. A Spec. B	X	X	X	X	X	X	X	X	X	X
GS r	X	X	X	X	X	X	X	X	X	X	X	X	X	X
GS v 0	x	x	x	○	x	x	x	x	x	x	x	x	x	x
GS w	x	x	x	○	x	x	x	x	x	x	x	x	x	x

• Kanji Control Commands (DBCS Settings, Kanji Specifications Only)

Commands	Model Name													
	TSP700	TSP600	TSP800	TUP900	TSP1000	TSP700II	TSP650	TUP500	TSP800II	FVP10	BSC10	TSP043	TSP650II	TSP650II SK
FS !	X	X	X	○	X	X	X	X	X	X	X	X	X	X
FS &	X	X	X	Spec. A	X	X	X	X	X	X	X	X	X	X
FS -	X	X	X	○	X	X	X	X	X	X	X	X	X	X
FS .	X	X	X	○	X	X	X	X	X	X	X	X	X	X
FS 2	X	X	X	○	X	X	X	X	X	X	X	X	X	X
FS C	X	X	X	○	X	X	X	X	X	X	X	X	X	X
FS S	X	X	X	○	X	X	X	X	X	X	X	X	X	X
FS W	X	X	X	○	X	X	X	X	X	X	X	X	X	X

## • ESC/POS Black Mark Related Commands (When black marks are effective)

Commands	Model Name														
	TSP700	TSP600	TSP800	TUP900	TSP1000	TSP700II	TSP650	TUP500	TSP800II	FVP10	BSC10	TSP043	TSP650II	TSP650IISK	
FF	X	X	X	○	X	X	X	X	X	X	X	X	X	X	
DLE ENQ	X	X	X	○	X	X	X	X	X	X	X	X	X	X	
GS FF	X	X	X	○	X	X	X	X	X	X	X	X	X	X	
GS ( F	X	X	X	○	X	X	X	X	X	X	X	X	X	X	
GS ( M n=1	X	X	X	○ (*)	X	X	X	X	X	X	X	X	X	X	
GS ( M n=2	X	X	X	○	X	X	X	X	X	X	X	X	X	X	
GS ( M n=3	X	X	X	○ (*)	X	X	X	X	X	X	X	X	X	X	
GS <	X	X	X	X	X	X	X	X	X	X	X	X	X	X	
GS V	X	X	X	○	X	X	X	X	X	X	X	X	X	X	

## • STAR Original Commands

Commands	Model Name														
	TSP700	TSP600	TSP800	TUP900	TSP1000	TSP700II	TSP650	TUP500	TSP800II	FVP10	BSC10	TSP043	TSP650II	TSP650IISK	
ESC GS =	X	X	X	○ (*)	X	X	X	X	X	X	X	X	X	X	
ESC GS t	X	X	X	Spec. A	X	X	X	X	X	X	X	X	X	X	
ESC GS +	X	X	X	X	X	X	X	X	X	X	X	X	X	X	
ESCGS#m	X	X	X	Spec. B (*)	X	X	X	X	X	X	X	X	X	X	
ESCRSF	X	X	X	X	X	X	X	X	X	X	X	X	X	X	
ESCRSC	X	X	X	X	X	X	X	X	X	X	X	X	X	X	
ESCRSL	X	X	X	X	X	X	X	X	X	X	X	X	X	X	
ESCGETX	X	X	X	X	X	X	X	X	X	X	X	X	X	X	

## • STAR Original Presenter Control Commands

Commands	Model Name														
	TSP700	TSP600	TSP800	TUP900	TSP1000	TSP700II	TSP650	TUP500	TSP800II	FVP10	BSC10	TSP043	TSP650II	TSP650IISK	
ESC SYN 0	X	X	X	○	X	X	X	X	X	X	X	X	X	X	
ESC SYN 1	X	X	X	○	X	X	X	X	X	X	X	X	X	X	
ESC SYN 3	X	X	X	X	X	X	X	X	X	X	X	X	X	X	
ESC SYN 4	X	X	X	○	X	X	X	X	X	X	X	X	X	X	
ESC GS SUB DC1	X	X	X	X	X	X	X	X	X	X	X	X	X	X	
ESC GS SUB DC2	X	X	X	X	X	X	X	X	X	X	X	X	X	X	
ESC GS SUB DC3	X	X	X	X	X	X	X	X	X	X	X	X	X	X	

• Star Original Mark Commands

Commands	Model Name													
	TSP700	TSP600	TSP800	TUP900	TSP1000	TSP700II	TSP650	TUP500	TSP800II	FVP10	BSC10	TSP043	TSP650II	TSP650IISK
ESC GS * 0	X	X	X	Ver3.0 or later	X	X	X	X	X	X	X	X	X	X
ESC GS * 1	X	X	X	Ver3.0 or later	X	X	X	X	X	X	X	X	X	X
ESC GS * 2	X	X	X	Ver3.0 or later	X	X	X	X	X	X	X	X	X	X
ESCGS*W	X	X	X	Ver3.0 or later	X	X	X	X	X	X	X	X	X	X
ESC GS * C	X	X	X	Ver3.0 or later	X	X	X	X	X	X	X	X	X	X

• STAR Original Auto Logo Commands

Commands	Model Name													
	TSP700	TSP600	TSP800	TUP900	TSP1000	TSP700II	TSP650	TUP500	TSP800II	FVP10	BSC10	TSP043	TSP650II	TSP650IISK
ESCGS/W	X	X	X	X	X	X	X	X	X	X	X	X	X	X
ESC GS / C	X	X	X	X	X	X	X	X	X	X	X	X	X	X
ESC GS / 1	X	X	X	X	X	X	X	X	X	X	X	X	X	X
ESC GS / 2	X	X	X	X	X	X	X	X	X	X	X	X	X	X
ESC GS / 3	X	X	X	X	X	X	X	X	X	X	X	X	X	X
ESC GS / 4	X	X	X	X	X	X	X	X	X	X	X	X	X	X
ESC GS / 5	X	X	X	X	X	X	X	X	X	X	X	X	X	X
ESC GS / 6	X	X	X	X	X	X	X	X	X	X	X	X	X	X

• Star Original Buzzer Commands

Commands	Model Name													
	TSP700	TSP600	TSP800	TUP900	TSP1000	TSP700II	TSP650	TUP500	TSP800II	FVP10	BSC10	TSP043	TSP650II	TSP650IISK
ESC GS BEL	X	X	X	X	X	X	X	X	X	X	X	X	X	X
ESC GS EM DC1	X	X	X	X	X	X	X	X	X	X	X	X	X	X
ESC GS EM DC 2	X	X	X	X	X	X	X	X	X	X	X	X	X	X

• Star Original PDF417 Commands

Commands	Model Name													
	TSP700	TSP600	TSP800	TUP900	TSP1000	TSP700II	TSP650	TUP500	TSP800II	FVP10	BSC10	TSP043	TSP650II	TSP650IISK
ESC GS x S 0	X	X	X	Ver3.1 or later	X	X	X	X	X	X	X	X	X	X
ESC GS x S 1	X	X	X	Ver3.1 or later	X	X	X	X	X	X	X	X	X	X
ESC GS x S 2	X	X	X	Ver3.1 or later	X	X	X	X	X	X	X	X	X	X
ESC GS x S 3	X	X	X	Ver3.1 or later	X	X	X	X	X	X	X	X	X	X
ESC GS x D	X	X	X	Ver3.1 or later	X	X	X	X	X	X	X	X	X	X
ESC GS x P	X	X	X	Ver3.1 or later	X	X	X	X	X	X	X	X	X	X
ESC GS x I	X	X	X	Ver3.1 or later	X	X	X	X	X	X	X	X	X	X

## • Star Original Print Starting Trigger Control Commands

Commands	Model Name													
	TSP700	TSP600	TSP800	TUP900	TSP1000	TSP700II	TSP650	TUP500	TSP800II	FVP10	BSC10	TSP043	TSP650II	TSP650IISK
ESC GS g 0	X	X	X	X	X	X	X	X	X	X	X	X	X	X
ESC GS g 1	X	X	X	X	X	X	X	X	X	X	X	X	X	X

## • Star Original QR Commands

Commands	Model Name													
	TSP700	TSP600	TSP800	TUP900	TSP1000	TSP700II	TSP650	TUP500	TSP800II	FVP10	BSC10	TSP043	TSP650II	TSP650IISK
ESC GS y S 0	X	X	X	X	X	X	X	X	X	X	X	X	X	X
ESC GS y S 1	X	X	X	X	X	X	X	X	X	X	X	X	X	X
ESC GS y S 2	X	X	X	X	X	X	X	X	X	X	X	X	X	X
ESC GS y D 1	X	X	X	X	X	X	X	X	X	X	X	X	X	X
ESC GS y D 2	X	X	X	X	X	X	X	X	X	X	X	X	X	X
ESC GS y P	X	X	X	X	X	X	X	X	X	X	X	X	X	X
ESC GS y I	X	X	X	X	X	X	X	X	X	X	X	X	X	X

## • Star Original Page Function Commands

Commands	Model Name													
	TSP700	TSP600	TSP800	TUP900	TSP1000	TSP700II	TSP650	TUP500	TSP800II	FVP10	BSC10	TSP043	TSP650II	TSP650IISK
ESC GS h 0	X	X	X	X	X	X	X	X	X	X	X	X	X	X
ESC GS h 1	X	X	X	X	X	X	X	X	X	X	X	X	X	X

## • Star Original Reduced Printing Function Command

Commands	Model Name													
	TSP700	TSP600	TSP800	TUP900	TSP1000	TSP700II	TSP650	TUP500	TSP800II	FVP10	BSC10	TSP043	TSP650II	TSP650IISK
ESC GS c	X	X	X	X	X	X	X	X	X	X	X	X	X	X

## • Star Original Text Search Commands

Commands	Model Name													
	TSP700	TSP600	TSP800	TUP900	TSP1000	TSP700II	TSP650	TUP500	TSP800II	FVP10	BSC10	TSP043	TSP650II	TSP650IISK
ESC GS ) B (fn = 48)	x	x	x	x	x	x	x	x	x	x	x	x	x	x
ESC GS ) B (fn = 49)	x	x	x	x	x	x	x	x	x	x	x	x	x	x
ESC GS ) B (fn = 50)	x	x	x	x	x	x	x	x	x	x	x	x	x	x
ESC GS ) B (fn = 64)	x	x	x	x	x	x	x	x	x	x	x	x	x	x
ESC GS ) B (fn = 65)	x	x	x	x	x	x	x	x	x	x	x	x	x	x
ESC GS ) B (fn = 66)	x	x	x	x	x	x	x	x	x	x	x	x	x	x
ESC GS ) B (fn = 80)	x	x	x	x	x	x	x	x	x	x	x	x	x	x
ESC GS ) B (fn = 81)	x	x	x	x	x	x	x	x	x	x	x	x	x	x
ESC GS ) B (fn = 96)	x	x	x	x	x	x	x	x	x	x	x	x	x	x
ESC GS ) B (fn = 97)	x	x	x	x	x	x	x	x	x	x	x	x	x	x

## • Star Original Printer Information Transmission Command

Commands	Model Name													
	TSP700	TSP600	TSP800	TUP900	TSP1000	TSP700II	TSP650	TUP500	TSP800II	FVP10	BSC10	TSP043	TSP650II	TSP650IISK
ESC GS ) I (fn = 48)	x	x	x	x	x	x	x	x	x	x	x	x	x	x

## • Star Original Individual Logo Command

Commands	Model Name													
	TSP700	TSP600	TSP800	TUP900	TSP1000	TSP700II	TSP650	TUP500	TSP800II	FVP10	BSC10	TSP043	TSP650II	TSP650IISK
ESC GS ) L (fn = 48)	x	x	x	x	x	x	x	x	x	x	x	x	x	x
ESC GS ) L (fn = 49)	x	x	x	x	x	x	x	x	x	x	x	x	x	x
ESC GS ) L (fn = 50)	x	x	x	x	x	x	x	x	x	x	x	x	x	x

## • Star Original Audio Commands

Commands	Model Name													
	TSP700	TSP600	TSP800	TUP900	TSP1000	TSP700II	TSP650	TUP500	TSP800II	FVP10	BSC10	TSP043	TSP650II	TSP650IISK
ESC GS s O	x	x	x	x	x	x	x	x	x	x	x	x	x	x
ESC GS s P	x	x	x	x	x	x	x	x	x	x	x	x	x	x
ESC GS s R	x	x	x	x	x	x	x	x	x	x	x	x	x	x
ESC GS s I	x	x	x	x	x	x	x	x	x	x	x	x	x	x
ESC GS s U	x	x	x	x	x	x	x	x	x	x	x	x	x	x
ESC GS s T	x	x	x	x	x	x	x	x	x	x	x	x	x	x

## • Star Original Hold print control Command

Commands	Model Name													
	TSP700	TSP600	TSP800	TUP900	TSP1000	TSP700II	TSP650	TUP500	TSP800II	FVP10	BSC10	TSP043	TSP650II	TSP650IISK
ESC SYN DC3	x	x	x	x	x	x	x	x	x	x	x	x	x	x
ESC SYN DC4	x	x	x	x	x	x	x	x	x	x	x	x	x	x
ESC GS ) s	x	x	x	x	x	x	x	x	x	x	x	x	x	x

**7-4 USB I/F (Ver 2.0)**

## • Standard Commands

Commands	Model Name													
	TSP700	TSP600	TSP800	TUP900	TSP1000	TSP700II	TSP650	TUP500	TSP800II	FVP10	BSC10	TSP043	TSP650II	TSP650IISK
HT	X	X	X	○	○	○	○	○	○	○	○	○	○	○
LF	X	X	X	○	○	○	○	○	○	○	○	○	○	○
FF	X	X	X	○	○	○	○	○	○	○	○	○	○	○
CR	X	X	X	X	X	X	X	X	X	X	X	X	X	X
CAN	X	X	X	○	○	○	○	○	○	○	○	○	○	○
DLE EOT	X	X	X	Spec. B	Spec. B	Spec. B-1 Ver. 1.4 or older Spec. B-2 Ver. 2.0 or later	Spec. B-1 Ver. 1.4 or older Spec. B-2 Ver. 2.0 or later	Spec. B-1 Ver. 1.0 Spec. B-2 Ver. 2.0 or later	Spec. B-2	Spec. B-2	Spec. B-2	Spec. B-2	Spec. B-2	Spec. B-2
DLE ENQ	X	X	X	X	X	X	X	X	X	X	X	X	X	X
DLE DC4	X	X	X	X	X	○	○	○	○	○	○	○	○	○
ESC FF	X	X	X	○	○	○	○	○	○	○	○	○	○	○
ESC SP	X	X	X	○	○	○	○	○	○	○	○	○	○	○
ESC !	X	X	X	○	○	○	○	○	○	○	○	○	○	○
ESC \$	X	X	X	○	○	○	○	○	○	○	○	○	○	○
ESC %	X	X	X	○	○	○	○	○	○	○	○	○	○	○
ESC &	X	X	X	○	○	○	○	○	○	○	○	○	○	○
ESC *	X	X	X	Spec. A	Spec. A	Spec. A	Spec. A	Spec. A	Spec. A	Spec. A	Spec. A	Spec. A	Spec. B	Spec. B
ESC -	X	X	X	○	○	○	○	○	○	○	○	○	○	○
ESC 2	X	X	X	○	○	○	○	○	○	○	○	○	○	○
ESC 3	X	X	X	○	○	○	○	○	○	○	○	○	○	○
ESC =	X	X	X	X	X	○	○	○	○	○	○	○	○	○
ESC ?	X	X	X	○	○	○	○	○	○	○	○	○	○	○
ESC @	X	X	X	○	○	○	○	○	○	○	○	○	○	○
ESC D	X	X	X	○	○	○	○	○	○	○	○	○	○	○
ESC E	X	X	X	○	○	○	○	○	○	○	○	○	○	○
ESC G	X	X	X	○	○	○	○	○	○	○	○	○	○	○
ESC J	X	X	X	○	○	○	○	○	○	○	○	○	○	○
ESC L	X	X	X	○	○	○	○	○	○	○	○	○	○	○
ESC M	X	X	X	○	○	○	○	○	○	○	○	○	○	○
ESC R	X	X	X	Spec.A	Spec.A	Spec.A	Spec.A	Spec.A	Spec.A	Spec.A	Spec.A Ver. 1.0 to Ver. 1.2 Spec. B Ver. 1.3 or later	Spec. A Ver. 1.0 to Ver. 1.2 Spec. B Ver. 1.3 or late	Spec.B	Spec.B
ESC S	X	X	X	○	○	○	○	○	○	○	○	○	○	○
ESC T	X	X	X	○	○	○	○	○	○	○	○	○	○	○
ESC V	X	X	X	○	○	○	○	○	○	○	○	○	○	○
ESC W	X	X	X	○	○	○	○	○	○	○	○	○	○	○
ESC \	X	X	X	○	○	○	○	○	○	○	○	○	○	○
ESC a	X	X	X	○	○	○	○	○	○	○	○	○	○	○
ESC c 3	X	X	X	X	X	X	X	X	X	X	X	X	X	X
ESC c 4	X	X	X	○	○	○	○	○	○	○	○	○	○	○
ESC c 5	X	X	X	○	○	○	○	○	○	○	○	○	○	○
ESC d	X	X	X	○	○	○	○	○	○	○	○	○	○	○
ESC p	X	X	X	X	X	○	○	X	○	○	○	○	○	○
ESC t	X	X	X	Spec.A	Spec.A	Spec.A	Spec.A	Spec.A	Spec.A	Spec.A	Spec.B	Spec.B	Spec.B	Spec.B
ESC {	X	X	X	○	○	○	○	○	○	○	○	○	○	○
FS g 1	X	X	X	X	X	X	X	X	X	X	X	X	X	X
FS g 2	X	X	X	X	X	X	X	X	X	X	X	X	X	X
FS p	X	X	X	○	○	○	○	○	○	○	○	○	○	○



Commands	Model Name													
	TSP700	TSP600	TSP800	TUP900	TSP1000	TSP700II	TSP650	TUP500	TSP800II	FVP10	BSC10	TSP043	TSP650II	TSP650IISK
FS q	x	x	x	o	o	o	o	o	o	o	o	o	o	o
GS !	x	x	x	o	o	o	o	o	o	o	o	o	o	o
GS \$	x	x	x	o	o	o	o	o	o	o	o	o	o	o
GS *	x	x	x	o	o	o	o	o	o	o	o	o	o	o
GS ( A	x	x	x	o	o	o	o	o	o	o	o	o	o	o
GS ( K (fn=49)	x	x	x	Spec.A	Spec.A	Spec.A	Spec.A	Spec.A	Spec.B	Spec.B	Spec.C	Spec.C	Spec.C	x
GS ( K (fn=50)	x	x	x	x	x	x	x	x	x	x	Spec.A	Spec.A	Spec.A	Spec.B
GS ( L (fn=48)	x	x	x	x	x	x	x	x	x	x	o	o	o	o
GS ( L (fn=51)	x	x	x	x	x	x	x	x	x	x	o	o	o	o
GS ( L (fn=64)	x	x	x	x	x	x	x	x	x	x	o	o	o	o
GS ( L (fn=65)	x	x	x	x	x	x	x	x	x	x	o	o	o	o
GS ( L (fn=66)	x	x	x	x	x	x	x	x	x	x	o	o	o	o
GS ( L (fn=67)	x	x	x	x	x	x	x	x	x	x	o	o	o	o
GS ( L (fn=69)	x	x	x	x	x	x	x	x	x	x	o	o	o	o
GS ( L (fn=112)	x	x	x	x	x	Ver2.0 or later	Ver2.0 or later	o	o	o	o	o	o	o
GS 8 L (fn=48)	x	x	x	x	x	x	x	x	x	x	o	o	o	o
GS 8 L (fn=51)	x	x	x	x	x	x	x	x	x	x	o	o	o	o
GS 8 L (fn=64)	x	x	x	x	x	x	x	x	x	x	o	o	o	o
GS 8 L (fn=65)	x	x	x	x	x	x	x	x	x	x	o	o	o	o
GS 8 L (fn=66)	x	x	x	x	x	x	x	x	x	x	o	o	o	o
GS 8 L (fn=67)	x	x	x	x	x	x	x	x	x	x	o	o	o	o
GS 8 L (fn=69)	x	x	x	x	x	x	x	x	x	x	o	o	o	o
GS 8 L (fn=112)	x	x	x	x	x	Ver2.0 or later	Ver2.0 or later	o	o	o	o	o	o	o
GS ( N	x	x	x	o	o	o	o	o	o	o	o	o	o	o
GS ( k (cn=48,fn=65)	x	x	x	x	x	x	x	x	x	x	o	o	o	o
GS ( k (cn=48,fn=66)	x	x	x	x	x	x	x	x	x	x	o	o	o	o
GS ( k (cn=48,fn=67)	x	x	x	x	x	x	x	x	x	x	o	o	o	o
GS ( k (cn=48,fn=68)	x	x	x	x	x	x	x	x	x	x	o	o	o	o
GS ( k (cn=48,fn=69)	x	x	x	x	x	x	x	x	x	x	o	o	o	o
GS ( k (cn=48,fn=70)	x	x	x	x	x	x	x	x	x	x	o	o	o	o
GS ( k (cn=48,fn=80)	x	x	x	x	x	x	x	x	x	x	o	o	o	o
GS ( k (cn=48,fn=81)	x	x	x	x	x	x	x	x	x	x	o	o	o	o
GS ( k (cn=48,fn=82)	x	x	x	x	x	x	x	x	x	x	o Ver. 1.8 or older x Ver. 1.9 or later	o	o Ver. 1.2 or older x Ver. 2.0 or later	x
GS ( k (cn=49,fn=65)	x	x	x	x	x	x	x	x	x	x	o	o	o	o
GS ( k (cn=49,fn=67)	x	x	x	x	x	x	x	x	x	x	o	o	o	o
GS ( k (cn=49,fn=69)	x	x	x	x	x	x	x	x	x	x	o	o	o	o
GS ( k (cn=49,fn=80)	x	x	x	x	x	x	x	x	x	x	o	o	o	o
GS ( k (cn=49,fn=81)	x	x	x	x	x	x	x	x	x	x	o	o	o	o
GS ( k (cn=49,fn=82)	x	x	x	x	x	x	x	x	x	x	o Ver. 1.8 or older x Ver. 1.9 or later	o	o Ver. 1.2 or older x Ver. 2.0 or later	x
GS ( k (cn=51,fn=67)	x	x	x	x	x	x	x	x	x	x	x	x	Ver.2.0 or later	o
GS ( k (cn=51,fn=71)	x	x	x	x	x	x	x	x	x	x	x	x	Ver.2.0 or later	o
GS ( k (cn=51,fn=80)	x	x	x	x	x	x	x	x	x	x	x	x	Ver.2.0 or later	o
GS ( k (cn=51,fn=81)	x	x	x	x	x	x	x	x	x	x	x	x	Ver.2.0 or later	o

Commands	Model Name													
	TSP700	TSP600	TSP800	TUP900	TSP1000	TSP700II	TSP650	TUP500	TSP800II	FVP10	BSC10	TSP043	TSP650II	TSP650II SK
GS ( k (cn=52,fn=67)	x	x	x	x	x	x	x	x	x	x	x	x	Ver.2.0 or later	o
GS ( k (cn=52,fn=71)	x	x	x	x	x	x	x	x	x	x	x	x	Ver.2.0 or later	o
GS ( k (cn=52,fn=72)	x	x	x	x	x	x	x	x	x	x	x	x	Ver.2.0 or later	o
GS ( k (cn=52,fn=80)	x	x	x	x	x	x	x	x	x	x	x	x	Ver.2.0 or later	o
GS ( k (cn=52,fn=81)	x	x	x	x	x	x	x	x	x	x	x	x	Ver.2.0 or later	o
GS /	x	x	x	o	o	o	o	o	o	o	o	o	o	o
GS :	x	x	x	o	o	o	o	o	o	o	o	o	o	o
GS B	x	x	x	o	o	o	o	o	o	o	o	o	o	o
GS C 0	x	x	x	o	o	o	o	o	o	o	x	x	o	o
GS C 1	x	x	x	o	o	o	o	o	o	o	x	x	o	o
GS C 2	x	x	x	o	o	o	o	o	o	o	x	x	o	o
GS C ;	x	x	x	o	o	o	o	o	o	o	x	x	o	o
GS E	x	x	x	Spec. A	Spec. A	Spec. A	Spec. A	Spec. A	Spec. A	Spec. A	x	x	Spec. A	Spec. B
GS H	x	x	x	o	o	o	o	o	o	o	o	o	o	o
GS I	x	x	x	Spec. A Ver. 4.4 or older Spec. B Ver. 4.5 or later	Spec. A	Spec. A Ver. 3.0 or older Spec. B Ver. 3.1 or later	Spec. A Ver. 3.0 or older Spec. B Ver. 3.1 or later	Spec. A Ver. 3.2 or older Spec. B Ver. 3.3 or later	Spec. A	Spec. B	Spec. B	Spec. B	Spec. B	Spec. B
GS L	x	x	x	o	o	o	o	o	o	o	o	o	o	o
GS P	x	x	x	x	x	o	o	x	o	o	o	o	o	o
GS T	x	x	x	o	o	o	o	o	o	o	o	o	o	o
GS V	x	x	x	o	o	o	o	o	o	o	o	o	o	o
GS W	x	x	x	o	o	o	o	o	o	o	o	o	o	o
GS \	x	x	x	o	o	o	o	o	o	o	o	o	o	o
GS ^	x	x	x	o	o	o	o	o	o	o	o	o	o	o
GS b	x	x	x	x	x	x	x	x	x	x	Ver1.3 or later	Ver1.3 or later	o	o
GS c	x	x	x	o	o	o	o	o	o	o	x	x	o	o
GS f	x	x	x	o	o	o	o	o	o	o	o	o	o	o
GS h	x	x	x	o	o	o	o	o	o	o	o	o	o	o
GS k	x	x	x	Spec. A Spec. B	Spec. A Spec. B	Spec. A Spec. B	Spec. A Spec. B	Spec. A Spec. B	Spec. A Spec. B	Spec. A Spec. B	Spec. A Spec. B	Spec. A Spec. B	Spec. A, Spec. B: Ver. 1,2 or older  Spec. A, Spec. B, Spec. C: Ver.2.0 or later	Spec. A, Spec. B, Spec. C
GS r	x	x	x	o	o	o	o	o	o	o	o	o	o	o
GS v 0	x	x	x	o	o	o	o	o	o	o	o	o	o	o
GS w	x	x	x	o	o	o	o	o	o	o	o	o	o	o

## • Kanji Control Commands (DBCS Settings, Kanji Specifications Only)

Commands	Model Name													
	TSP700	TSP600	TSP800	TUP900	TSP1000	TSP700II	TSP650	TUP500	TSP800II	FVP10	BSC10	TSP043	TSP650II	TSP650IISK
FS !	X	X	X	○	○	○	○	○	○	○	○	○	○	○
FS &	X	X	X	Spec. A	Spec. A	Spec. A	Spec. A	Spec. A	Spec. A	Spec. A	Spec. B	Spec. B	Spec. A	Spec. A
FS -	X	X	X	○	○	○	○	○	○	○	○	○	○	○
FS .	X	X	X	○	○	○	○	○	○	○	○	○	○	○
FS 2	X	X	X	○	○	○	○	○	○	○	○	○	○	○
FS C	X	X	X	○	○	○	○	○	○	○	X	X	○	○
FS S	X	X	X	○	○	○	○	○	○	○	○	○	○	○
FS W	X	X	X	○	○	○	○	○	○	○	○	○	○	○

## • ESC/POS Black Mark Related Commands (When black marks are effective)

Commands	Model Name													
	TSP700	TSP600	TSP800	TUP900	TSP1000	TSP700II	TSP650	TUP500	TSP800II	FVP10	BSC10	TSP043	TSP650II	TSP650IISK
FF	X	X	X	○	○	○	X	X	○	○	○	○	X	X
DLE ENQ	X	X	X	○	○	○	X	X	○	○	○	○	X	X
GS FF	X	X	X	○	○	○	X	X	○	○	○	○	X	X
GS ( F	X	X	X	○	○	X	X	X	X	X	X	X	X	X
GS ( M n=1	X	X	X	○	○	X	X	X	X	X	X	X	X	X
GS ( M n=2	X	X	X	○	○	X	X	X	X	X	X	X	X	X
GS ( M n=3	X	X	X	○	○	X	X	X	X	X	X	X	X	X
GS <	X	X	X	X	X	○	X	X	○	○	○	○	X	X
GS V	X	X	X	○	○	○	X	X	○	○	○	○	X	X

## • STAR Original Commands

Commands	Model Name														
	TSP700	TSP600	TSP800	TUP900	TSP1000	TSP700II	TSP650	TUP500	TSP800II	FVP10	BSC10	TSP043	TSP650II	TSP650IISK	
ESC GS =	X	X	X	○	○	○	○	○	○	○	○	○	○	○	
ESC GS t	X	X	X	Spec. A	Spec. A	Spec. A	Spec. A	Spec. A	Spec. A	Spec. A	Spec. B	Spec. B	Spec. B	Spec. B	
ESC GS +	X	X	X	X	X	○	○	○	○	○	○	○	○	○	
ESCGS #m	X	X	X	Spec. B Ver.1.0~4.4 Spec. C Ver.5.0 or later	Spec. B	Spec. B Ver.1.0~4.4 Spec. C Ver.3.0 or later	Spec. B Ver.1.0~2.0 Spec. C Ver.3.0 or later	Spec. B Ver.1.0~2.0 Spec. C Ver.3.0 or later	Spec. B Ver.1.0~2.0 Spec. C Ver.3.0 or later	Spec. C	Spec. C	Spec. C	Spec. C	Spec. B	Spec. B
ESCRSF	X	X	X	X	○	○	○	○	○	○	○	○	○	○	
ESCRSC	X	X	X	X	X	○	○	○	○	○	X	X	○	X	
ESCRSL	X	X	X	X	X	Spec. A Ver.1.3~1.4 Spec. B Ver.2.0 or later	Spec. A Ver.1.0~1.4 Spec. B Ver.2.0 or later	Spec. B	Spec. B	Spec. B	Spec. B	Spec. B	Spec. B	Spec. B	Spec. B
ESCGSETX	X	X	X	X	X	Spec. A Ver. 2.0 or later Spec. B Ver. 3.0 or later	Spec. A Ver. 2.0 or later Spec. B Ver. 3.0 or later	Spec. A Ver. 2.0 or later Spec. B Ver. 3.0 or later	Spec. A Ver. 2.0 or later Spec. B Ver. 1.1 or later	Spec. B	Spec. B	Spec. B	Spec. B	Spec. B	Spec. B

## • STAR Original Presenter Control Commands

Commands	Model Name														
	TSP700	TSP600	TSP800	TUP900	TSP1000	TSP700II	TSP650	TUP500	TSP800II	FVP10	BSC10	TSP043	TSP650II	TSP650IISK	
ESC SYN 0	X	X	X	○	X	X	X	○	X	X	X	X	X	X	
ESC SYN 1	X	X	X	○	X	X	X	○	X	X	X	X	X	X	
ESC SYN 3	X	X	X	○	X	X	X	○	X	X	X	X	X	X	
ESC SYN 4	X	X	X	○	X	X	X	○	X	X	X	X	X	X	
ESC GS SUB DC1	X	X	X	X	X	X	X	○	X	X	X	X	X	X	
ESC GS SUB DC2	X	X	X	X	X	X	X	○	X	X	X	X	X	X	
ESC GS SUB DC3	X	X	X	X	X	X	X	○	X	X	X	X	X	X	

## • Star Original Mark Commands

Commands	Model Name														
	TSP700	TSP600	TSP800	TUP900	TSP1000	TSP700II	TSP650	TUP500	TSP800II	FVP10	BSC10	TSP043	TSP650II	TSP650IISK	
ESC GS * 0	X	X	X	Ver3.0 or later	○	○	○	○	○	○	○	○	○	○	
ESC GS * 1	X	X	X	Ver3.0 or later	○	○	○	○	○	○	○	○	○	○	
ESC GS * 2	X	X	X	Ver3.0 or later	○	○	○	○	○	○	○	○	○	○	
ESCGS *W	X	X	X	Ver3.0 or later	○	○	○	○	○	○	○	○	○	○	
ESC GS * C	X	X	X	Ver3.0 or later	○	○	○	○	○	○	○	○	○	○	

## • STAR Original Auto Logo Commands

Commands	Model Name													
	TSP700	TSP600	TSP800	TUP900	TSP1000	TSP700II	TSP650	TUP500	TSP800II	FVP10	BSC10	TSP043	TSP650II	TSP650IISK
ESCGS / W	X	X	X	X	X	o	o	X	o	o	Ver.1.3 or later	Ver.1.3 or later	o	o
ESC GS / C	X	X	X	X	X	o	o	X	o	o	Ver.1.3 or later	Ver.1.3 or later	o	o
ESC GS / 1	X	X	X	X	X	o	o	X	o	o	Ver.1.3 or later	Ver.1.3 or later	o	o
ESC GS / 2	X	X	X	X	X	o	o	X	o	o	Ver.1.3 or later	Ver.1.3 or later	o	o
ESC GS / 3	X	X	X	X	X	o	o	X	o	o	Ver.1.3 or later	Ver.1.3 or later	o	o
ESC GS / 4	X	X	X	X	X	o	o	X	o	o	Ver.1.3 or later	Ver.1.3 or later	o	o
ESC GS / 5	X	X	X	X	X	o	o	X	o	o	Ver.1.3 or later	Ver.1.3 or later	o	o
ESC GS / 6	X	X	X	X	X	o	o	X	o	o	Ver.1.3 or later	Ver.1.3 or later	o	o

## • Star Original Buzzer Commands

Commands	Model Name													
	TSP700	TSP600	TSP800	TUP900	TSP1000	TSP700II	TSP650	TUP500	TSP800II	FVP10	BSC10	TSP043	TSP650II	TSP650IISK
ESC GS BEL	X	X	X	X	o	o	o	X	o	o	o	o	o	o
ESC GS EM DC1	X	X	X	X	X	Ver1.3 or later	o	X	o	o	o	o	o	o
ESC GS EM DC2	X	X	X	X	X	Ver1.3 or later	o	X	o	o	o	o	o	o

## • Star Original PDF417 Commands

Commands	Model Name													
	TSP700	TSP600	TSP800	TUP900	TSP1000	TSP700II	TSP650	TUP500	TSP800II	FVP10	BSC10	TSP043	TSP650II	TSP650IISK
ESC GS x S 0	X	X	X	Ver3.1 or later	o	o	X	o	o	o	X	X	X	X
ESC GS x S 1	X	X	X	Ver3.1 or later	o	o	X	o	o	o	X	X	X	X
ESC GS x S 2	X	X	X	Ver3.1 or later	o	o	X	o	o	o	X	X	X	X
ESC GS x S 3	X	X	X	Ver3.1 or later	o	o	X	o	o	o	X	X	X	X
ESC GS x D	X	X	X	Ver3.1 or later	o	o	X	o	o	o	X	X	X	X
ESC GS x P	X	X	X	Ver3.1 or later	o	o	X	o	o	o	X	X	X	X
ESC GS x I	X	X	X	Ver3.1 or later	o	o	X	o	o	o	X	X	X	X

## • Star Original Print Starting Trigger Control Commands

Commands	Model Name														
	TSP700	TSP600	TSP800	TUP900	TSP1000	TSP700II	TSP650	TUP500	TSP800II	FVP10	BSC10	TSP043	TSP650II	TSP650IISK	
ESC GS g 0	X	X	X	X	Ver1.1 or later	○	○	○	○	○	○	○	○	○	
ESC GS g 1	X	X	X	X	Ver1.1 or later	○	○	○	○	○	○	○	○	○	

## • Star Original QR Commands

Commands	Model Name														
	TSP700	TSP600	TSP800	TUP900	TSP1000	TSP700II	TSP650	TUP500	TSP800II	FVP10	BSC10	TSP043	TSP650II	TSP650IISK	
ESC GS y S 0	X	X	X	X	Ver1.2 or later	○	X	○	○	○	X	X	X	X	
ESC GS y S 1	X	X	X	X	Ver1.2 or later	○	X	○	○	○	X	X	X	X	
ESC GS y S 2	X	X	X	X	Ver1.2 or later	○	X	○	○	○	X	X	X	X	
ESC GS y D 1	X	X	X	X	Ver1.2 or later	○	X	○	○	○	X	X	X	X	
ESC GS y D 2	X	X	X	X	Ver1.2 or later	○	X	○	○	○	X	X	X	X	
ESC GS y P	X	X	X	X	Ver1.2 or later	○	X	○	○	○	X	X	X	X	
ESC GS y I	X	X	X	X	Ver1.2 or later	○ Ver 5.1 or earlier X Ver 6.0 or later	X	○ Ver 4.2 or earlier X Ver 6.0 or later	○ Ver 2.1 or earlier X Ver 6.0 or later	○	X	X	X	X	

## • Star Original Page Function Commands

Commands	Model Name														
	TSP700	TSP600	TSP800	TUP900	TSP1000	TSP700II	TSP650	TUP500	TSP800II	FVP10	BSC10	TSP043	TSP650II	TSP650IISK	
ESC GS h 0	X	X	X	X	X	○	○	○	○	○	○	○	○	○	
ESC GS h 1	X	X	X	X	X	○	○	○	○	○	Ver1.3 or later	Ver1.3 or later	○	○	

## • Star Original Reduced Printing Function Command

Commands	Model Name														
	TSP700	TSP600	TSP800	TUP900	TSP1000	TSP700II	TSP650	TUP500	TSP800II	FVP10	BSC10	TSP043	TSP650II	TSP650IISK	
ESC GS c	X	X	X	X	X	X	X	X	X	○	○	○	○	X	

## • Star Original Text Search Commands

Commands	Model Name														
	TSP700	TSP600	TSP800	TUP900	TSP1000	TSP700II	TSP650	TUP500	TSP800II	FVP10	BSC10	TSP043	TSP650II	TSP650II SK	
ESC GS ) B (fn = 48)	X	X	X	X	X	X	X	X	X	○	○	○	○	○	
ESC GS ) B (fn = 49)	X	X	X	X	X	X	X	X	X	○	○	○	○	○	
ESC GS ) B (fn = 50)	X	X	X	X	X	X	X	X	X	○	○	○	○	○	
ESC GS ) B (fn = 64)	X	X	X	X	X	X	X	X	X	○	○	○	○	○	
ESC GS ) B (fn = 65)	X	X	X	X	X	X	X	X	X	○	○	○	○	○	
ESC GS ) B (fn = 66)	X	X	X	X	X	X	X	X	X	X	Ver1.3 or later	Ver1.3 or later	○	○	
ESC GS ) B (fn = 80)	X	X	X	X	X	X	X	X	X	○	○	○	○	○	
ESC GS ) B (fn = 81)	X	X	X	X	X	X	X	X	X	○	○	○	○	○	
ESC GS ) B (fn = 96)	X	X	X	X	X	X	X	X	X	○	○	○	○	○	
ESC GS ) B (fn = 97)	X	X	X	X	X	X	X	X	X	○	○	○	○	○	

## • Star Original Printer Information Transmission Command

Commands	Model Name														
	TSP700	TSP600	TSP800	TUP900	TSP1000	TSP700II	TSP650	TUP500	TSP800II	FVP10	BSC10	TSP043	TSP650II	TSP650II SK	
ESC GS ) I (fn = 48)	X	X	X	X	X	X	X	X	X	X	Ver1.3 or later	Ver1.3 or later	○	○	

## • Star Original Individual Logo Command

Commands	Model Name														
	TSP700	TSP600	TSP800	TUP900	TSP1000	TSP700II	TSP650	TUP500	TSP800II	FVP10	BSC10	TSP043	TSP650II	TSP650II SK	
ESC GS ) L (fn = 48)	X	X	X	X	X	X	X	X	X	X	○	○	○	○	
ESC GS ) L (fn = 49)	X	X	X	X	X	X	X	X	X	X	Ver1.3 or later	Ver1.3 or later	○	○	
ESC GS ) L (fn = 50)	X	X	X	X	X	X	X	X	X	X	Spec.A Ver1.3 or later	Spec.A Ver1.3 or later	Spec. B	Spec. B	

## • Star Original Audio Commands

Commands	Model Name														
	TSP700	TSP600	TSP800	TUP900	TSP1000	TSP700II	TSP650	TUP500	TSP800II	FVP10	BSC10	TSP043	TSP650II	TSP650II SK	
ESC GS s O	X	X	X	X	X	X	X	X	X	○	X	X	X	X	
ESC GS s P	X	X	X	X	X	X	X	X	X	○	X	X	X	X	
ESC GS s R	X	X	X	X	X	X	X	X	X	○	X	X	X	X	
ESC GS s I	X	X	X	X	X	X	X	X	X	○	X	X	X	X	
ESC GS s U	X	X	X	X	X	X	X	X	X	○	X	X	X	X	
ESC GS s T	X	X	X	X	X	X	X	X	X	○	X	X	X	X	

• Star Original Hold print control Command

Commands	Model Name													
	TSP700	TSP600	TSP800	TUP900	TSP1000	TSP700II	TSP650	TUP500	TSP800II	FVP10	BSC10	TSP043	TSP650II	TSP650IISK
ESC SYN DC3	X	X	X	X	X	X	X	X	X	X	X	X	X	○
ESC SYN DC4	X	X	X	X	X	X	X	X	X	X	X	X	X	○
ESC GS ) s	X	X	X	X	X	X	X	X	X	X	X	X	X	○

On USB printer class, the following models ignore the status request command.

- TSP700, TSP600, TSP800, TUP900, TSP1000, TSP700II, Ver. 1.0 to Ver.1.4, TSP650 Ver. 1.0 to Ver. 1.4



**7-5 Powered USB I/F**

## • Standard Commands

Commands	Model Name													
	TSP700	TSP600	TSP800	TUP900	TSP1000	TSP700II	TSP650	TUP500	TSP800II	FVP10	BSC10	TSP043	TSP650II	TSP650II SK
HT	X	X	X	X	X	X	X	X	X	○	X	X	X	X
LF	X	X	X	X	X	X	X	X	X	○	X	X	X	X
FF	X	X	X	X	X	X	X	X	X	○	X	X	X	X
CR	X	X	X	X	X	X	X	X	X	X	X	X	X	X
CAN	X	X	X	X	X	X	X	X	X	○	X	X	X	X
DLE EOT	X	X	X	X	X	X	X	X	X	Spec. B-2	X	X	X	X
DLE ENQ	X	X	X	X	X	X	X	X	X	X	X	X	X	X
DLE DC4	X	X	X	X	X	X	X	X	X	○	X	X	X	X
ESC FF	X	X	X	X	X	X	X	X	X	○	X	X	X	X
ESC SP	X	X	X	X	X	X	X	X	X	○	X	X	X	X
ESC !	X	X	X	X	X	X	X	X	X	○	X	X	X	X
ESC \$	X	X	X	X	X	X	X	X	X	○	X	X	X	X
ESC %	X	X	X	X	X	X	X	X	X	○	X	X	X	X
ESC &	X	X	X	X	X	X	X	X	X	○	X	X	X	X
ESC *	X	X	X	X	X	X	X	X	X	Spec.A	X	X	X	X
ESC -	X	X	X	X	X	X	X	X	X	○	X	X	X	X
ESC 2	X	X	X	X	X	X	X	X	X	○	X	X	X	X
ESC 3	X	X	X	X	X	X	X	X	X	○	X	X	X	X
ESC =	X	X	X	X	X	X	X	X	X	○	X	X	X	X
ESC ?	X	X	X	X	X	X	X	X	X	○	X	X	X	X
ESC @	X	X	X	X	X	X	X	X	X	○	X	X	X	X
ESC D	X	X	X	X	X	X	X	X	X	○	X	X	X	X
ESC E	X	X	X	X	X	X	X	X	X	○	X	X	X	X
ESC G	X	X	X	X	X	X	X	X	X	○	X	X	X	X
ESC J	X	X	X	X	X	X	X	X	X	○	X	X	X	X
ESC L	X	X	X	X	X	X	X	X	X	○	X	X	X	X
ESC M	X	X	X	X	X	X	X	X	X	○	X	X	X	X
ESC R	X	X	X	X	X	X	X	X	X	Spec.A	X	X	X	X
ESC S	X	X	X	X	X	X	X	X	X	○	X	X	X	X
ESC T	X	X	X	X	X	X	X	X	X	○	X	X	X	X
ESC V	X	X	X	X	X	X	X	X	X	○	X	X	X	X
ESC W	X	X	X	X	X	X	X	X	X	○	X	X	X	X
ESC \	X	X	X	X	X	X	X	X	X	○	X	X	X	X
ESC a	X	X	X	X	X	X	X	X	X	○	X	X	X	X
ESC c 3	X	X	X	X	X	X	X	X	X	X	X	X	X	X
ESC c 4	X	X	X	X	X	X	X	X	X	○	X	X	X	X
ESC c 5	X	X	X	X	X	X	X	X	X	○	X	X	X	X
ESC d	X	X	X	X	X	X	X	X	X	○	X	X	X	X
ESC p	X	X	X	X	X	X	X	X	X	○	X	X	X	X
ESC t	X	X	X	X	X	X	X	X	X	Spec.A	X	X	X	X
ESC {	X	X	X	X	X	X	X	X	X	○	X	X	X	X
FS g 1	X	X	X	X	X	X	X	X	X	X	X	X	X	X
FS g 2	X	X	X	X	X	X	X	X	X	X	X	X	X	X
FS p	X	X	X	X	X	X	X	X	X	○	X	X	X	X
FS q	X	X	X	X	X	X	X	X	X	○	X	X	X	X
GS !	X	X	X	X	X	X	X	X	X	○	X	X	X	X
GS \$	X	X	X	X	X	X	X	X	X	○	X	X	X	X
GS *	X	X	X	X	X	X	X	X	X	○	X	X	X	X
GS (A	X	X	X	X	X	X	X	X	X	○	X	X	X	X

Commands	Model Name													
	TSP700	TSP600	TSP800	TUP900	TSP1000	TSP700II	TSP650	TUP500	TSP800II	FVP10	BSC10	TSP043	TSP650II	TSP650II SK
GS ( K (fn=49)	X	X	X	X	X	X	X	X	X	Spec.B	X	X	X	X
GS ( K (fn=50)	X	X	X	X	X	X	X	X	X	X	X	X	X	X
GS ( L (fn=48)	X	X	X	X	X	X	X	X	X	X	X	X	X	X
GS ( L (fn=51)	X	X	X	X	X	X	X	X	X	X	X	X	X	X
GS ( L (fn=64)	X	X	X	X	X	X	X	X	X	X	X	X	X	X
GS ( L (fn=65)	X	X	X	X	X	X	X	X	X	X	X	X	X	X
GS ( L (fn=66)	X	X	X	X	X	X	X	X	X	X	X	X	X	X
GS ( L (fn=67)	X	X	X	X	X	X	X	X	X	X	X	X	X	X
GS ( L (fn=69)	X	X	X	X	X	X	X	X	X	X	X	X	X	X
GS ( L (fn=112)	X	X	X	X	X	X	X	X	X	o	X	X	X	X
GS 8 L (fn=48)	X	X	X	X	X	X	X	X	X	X	X	X	X	X
GS 8 L (fn=51)	X	X	X	X	X	X	X	X	X	X	X	X	X	X
GS 8 L (fn=64)	X	X	X	X	X	X	X	X	X	X	X	X	X	X
GS 8 L (fn=65)	X	X	X	X	X	X	X	X	X	X	X	X	X	X
GS 8 L (fn=66)	X	X	X	X	X	X	X	X	X	X	X	X	X	X
GS 8 L (fn=67)	X	X	X	X	X	X	X	X	X	X	X	X	X	X
GS 8 L (fn=69)	X	X	X	X	X	X	X	X	X	X	X	X	X	X
GS 8 L (fn=112)	X	X	X	X	X	X	X	X	X	o	X	X	X	X
GS ( N	X	X	X	X	X	X	X	X	X	o	X	X	X	X
GS ( k (cn=48,fn=65)	x	x	x	x	x	x	x	x	x	x	x	x	x	x
GS ( k (cn=48,fn=66)	x	x	x	x	x	x	x	x	x	x	x	x	x	x
GS ( k (cn=48,fn=67)	x	x	x	x	x	x	x	x	x	x	x	x	x	x
GS ( k (cn=48,fn=68)	x	x	x	x	x	x	x	x	x	x	x	x	x	x
GS ( k (cn=48,fn=69)	x	x	x	x	x	x	x	x	x	x	x	x	x	x
GS ( k (cn=48,fn=70)	x	x	x	x	x	x	x	x	x	x	x	x	x	x
GS ( k (cn=48,fn=80)	x	x	x	x	x	x	x	x	x	x	x	x	x	x
GS ( k (cn=48,fn=81)	x	x	x	x	x	x	x	x	x	x	x	x	x	x
GS ( k (cn=48,fn=82)	x	x	x	x	x	x	x	x	x	x	x	x	x	x
GS ( k (cn=49,fn=65)	x	x	x	x	x	x	x	x	x	x	x	x	x	x
GS ( k (cn=49,fn=67)	x	x	x	x	x	x	x	x	x	x	x	x	x	x
GS ( k (cn=49,fn=69)	x	x	x	x	x	x	x	x	x	x	x	x	x	x
GS ( k (cn=49,fn=80)	x	x	x	x	x	x	x	x	x	x	x	x	x	x
GS ( k (cn=49,fn=81)	x	x	x	x	x	x	x	x	x	x	x	x	x	x
GS ( k (cn=49,fn=82)	x	x	x	x	x	x	x	x	x	x	x	x	x	x
GS ( k (cn=51,fn=67)	x	x	x	x	x	x	x	x	x	x	x	x	x	x
GS ( k (cn=51,fn=71)	x	x	x	x	x	x	x	x	x	x	x	x	x	x
GS ( k (cn=51,fn=80)	x	x	x	x	x	x	x	x	x	x	x	x	x	x
GS ( k (cn=51,fn=81)	x	x	x	x	x	x	x	x	x	x	x	x	x	x
GS ( k (cn=52,fn=67)	x	x	x	x	x	x	x	x	x	x	x	x	x	x
GS ( k (cn=52,fn=71)	x	x	x	x	x	x	x	x	x	x	x	x	x	x
GS ( k (cn=52,fn=72)	x	x	x	x	x	x	x	x	x	x	x	x	x	x
GS ( k (cn=52,fn=80)	x	x	x	x	x	x	x	x	x	x	x	x	x	x
GS ( k (cn=52,fn=81)	x	x	x	x	x	x	x	x	x	x	x	x	x	x
GS /	X	X	X	X	X	X	X	X	X	o	X	X	X	X
GS :	X	X	X	X	X	X	X	X	X	o	X	X	X	X
GS B	X	X	X	X	X	X	X	X	X	o	X	X	X	X
GS C 0	X	X	X	X	o	o	X	X	X	o	X	X	X	X
GS C 1	X	X	X	X	o	o	X	X	X	o	X	X	X	X
GS C 2	X	X	X	X	o	o	X	X	X	o	X	X	X	X
GS C ;	X	X	X	X	o	o	X	X	X	o	X	X	X	X

Commands	Model Name													
	TSP700	TSP600	TSP800	TUP900	TSP1000	TSP700II	TSP650	TUP500	TSP800II	FVP10	BSC10	TSP043	TSP650II	TSP650IISK
GS E	X	X	X	X	X	X	X	X	X	Spec. B	X	X	X	X
GS H	X	X	X	X	X	X	X	X	X	○	X	X	X	X
GS I	X	X	X	X	X	X	X	X	X	Spec. B	X	X	X	X
GS L	X	X	X	X	X	X	X	X	X	○	X	X	X	X
GS P	X	X	X	X	X	X	X	X	X	○	X	X	X	X
GS T	X	X	X	X	X	X	X	X	X	○	X	X	X	X
GS V	X	X	X	X	X	X	X	X	X	○	X	X	X	X
GS W	X	X	X	X	X	X	X	X	X	○	X	X	X	X
GS \	X	X	X	X	X	X	X	X	X	○	X	X	X	X
GS ^	X	X	X	X	X	X	X	X	X	○	X	X	X	X
GS b	X	X	X	X	X	X	X	X	X	X	X	X	X	X
GS c	X	X	X	X	X	X	X	X	X	○	X	X	X	X
GS f	X	X	X	X	X	X	X	X	X	○	X	X	X	X
GS h	X	X	X	X	X	X	X	X	X	○	X	X	X	X
GS k	X	X	X	X	X	X	X	X	X	Spec. A Spec. B	X	X	X	X
GS r	X	X	X	X	X	X	X	X	X	○	X	X	X	X
GS v 0	X	X	X	X	X	X	X	X	X	○	X	X	X	X
GS w	X	X	X	X	X	X	X	X	X	○	X	X	X	X

• Kanji Control Commands (DBCS Settings, Kanji Specifications Only)

Commands	Model Name													
	TSP700	TSP600	TSP800	TUP900	TSP1000	TSP700II	TSP650	TUP500	TSP800II	FVP10	BSC10	TSP043	TSP650II	TSP650IISK
FS !	X	X	X	X	X	X	X	X	X	○	X	X	X	X
FS &	X	X	X	X	X	X	X	X	X	Spec. A	X	X	X	X
FS -	X	X	X	X	X	X	X	X	X	○	X	X	X	X
FS .	X	X	X	X	X	X	X	X	X	○	X	X	X	X
FS 2	X	X	X	X	X	X	X	X	X	○	X	X	X	X
FS C	X	X	X	X	X	X	X	X	X	○	X	X	X	X
FS S	X	X	X	X	X	X	X	X	X	○	X	X	X	X
FS W	X	X	X	X	X	X	X	X	X	○	X	X	X	X

## • ESC/POS Black Mark Related Commands (When black marks are effective)

Commands	Model Name														
	TSP700	TSP600	TSP800	TUP900	TSP1000	TSP700II	TSP650	TUP500	TSP800II	FVP10	BSC10	TSP043	TSP650II	TSP650IIISK	
FF	X	X	X	X	X	X	X	X	X	○	X	X	X	X	
DLE ENQ	X	X	X	X	X	X	X	X	X	○	X	X	X	X	
GS FF	X	X	X	X	X	X	X	X	X	○	X	X	X	X	
GS ( F	X	X	X	X	X	X	X	X	X	X	X	X	X	X	
GS ( M n=1	X	X	X	X	X	X	X	X	X	X	X	X	X	X	
GS ( M n=2	X	X	X	X	X	X	X	X	X	X	X	X	X	X	
GS ( M n=3	X	X	X	X	X	X	X	X	X	X	X	X	X	X	
GS <	X	X	X	X	X	X	X	X	X	○	X	X	X	X	
GS V	X	X	X	X	X	X	X	X	X	○	X	X	X	X	

## • STAR Original Commands

Commands	Model Name														
	TSP700	TSP600	TSP800	TUP900	TSP1000	TSP700II	TSP650	TUP500	TSP800II	FVP10	BSC10	TSP043	TSP650II	TSP650IIISK	
ESC GS =	X	X	X	X	X	X	X	X	X	○	X	X	X	X	
ESC GS t	X	X	X	X	X	X	X	X	X	Spec. B	X	X	X	X	
ESC GS +	X	X	X	X	X	X	X	X	X	○	X	X	X	X	
ESC GS #m	X	X	X	X	X	X	X	X	X	Spec. C	X	X	X	X	
ESCRSF	X	X	X	X	X	X	X	X	X	○	X	X	X	X	
ESCRSC	X	X	X	X	X	X	X	X	X	○	X	X	X	X	
ESCRSL	X	X	X	X	X	X	X	X	X	Spec. B	X	X	X	X	
ESCGETX	X	X	X	X	X	X	X	X	X	Spec. B	X	X	X	X	

## • STAR Original Presenter Control Commands

Commands	Model Name														
	TSP700	TSP600	TSP800	TUP900	TSP1000	TSP700II	TSP650	TUP500	TSP800II	FVP10	BSC10	TSP043	TSP650II	TSP650IIISK	
ESC SYN 0	X	X	X	○	X	X	X	○	X	X	X	X	X	X	
ESC SYN 1	X	X	X	○	X	X	X	○	X	X	X	X	X	X	
ESC SYN 3	X	X	X	○	X	X	X	○	X	X	X	X	X	X	
ESC SYN 4	X	X	X	○	X	X	X	○	X	X	X	X	X	X	
ESC GS SUB DC1	X	X	X	X	X	X	X	○	X	X	X	X	X	X	
ESC GS SUB DC2	X	X	X	X	X	X	X	○	X	X	X	X	X	X	
ESC GS SUB DC3	X	X	X	X	X	X	X	○	X	X	X	X	X	X	

## • Star Original Mark Commands

Commands	Model Name														
	TSP700	TSP600	TSP800	TUP900	TSP1000	TSP700II	TSP650	TUP500	TSP800II	FVP10	BSC10	TSP043	TSP650II	TSP650IIISK	
ESC GS * 0	X	X	X	X	X	X	X	X	X	○	X	X	X	X	
ESC GS * 1	X	X	X	X	X	X	X	X	X	○	X	X	X	X	
ESC GS * 2	X	X	X	X	X	X	X	X	X	○	X	X	X	X	
ESCGS * W	X	X	X	X	X	X	X	X	X	○	X	X	X	X	
ESC GS * C	X	X	X	X	X	X	X	X	X	○	X	X	X	X	

## • STAR Original Auto Logo Commands

Commands	Model Name														
	TSP700	TSP600	TSP800	TUP900	TSP1000	TSP700II	TSP650	TUP500	TSP800II	FVP10	BSC10	TSP043	TSP650II	TSP650IIISK	
ESCGS / W	X	X	X	X	X	X	X	X	X	○	X	X	X	X	
ESC GS / C	X	X	X	X	X	X	X	X	X	○	X	X	X	X	
ESC GS / 1	X	X	X	X	X	X	X	X	X	○	X	X	X	X	
ESC GS / 2	X	X	X	X	X	X	X	X	X	○	X	X	X	X	
ESC GS / 3	X	X	X	X	X	X	X	X	X	○	X	X	X	X	
ESC GS / 4	X	X	X	X	X	X	X	X	X	○	X	X	X	X	
ESC GS / 5	X	X	X	X	X	X	X	X	X	○	X	X	X	X	
ESC GS / 6	X	X	X	X	X	X	X	X	X	○	X	X	X	X	

## • Star Original Buzzer Commands

Commands	Model Name														
	TSP700	TSP600	TSP800	TUP900	TSP1000	TSP700II	TSP650	TUP500	TSP800II	FVP10	BSC10	TSP043	TSP650II	TSP650IIISK	
ESC GS BEL	X	X	X	X	X	X	X	X	X	○	X	X	X	X	
ESC GS EM DC1	X	X	X	X	X	X	X	X	X	○	X	X	X	X	
ESC GS EM DC2	X	X	X	X	X	X	X	X	X	○	X	X	X	X	

## • Star Original PDF417 Commands

Commands	Model Name														
	TSP700	TSP600	TSP800	TUP900	TSP1000	TSP700II	TSP650	TUP500	TSP800II	FVP10	BSC10	TSP043	TSP650II	TSP650IIISK	
ESC GS x S 0	X	X	X	X	X	X	X	X	X	○	X	X	X	X	
ESC GS x S 1	X	X	X	X	X	X	X	X	X	○	X	X	X	X	
ESC GS x S 2	X	X	X	X	X	X	X	X	X	○	X	X	X	X	
ESC GS x S 3	X	X	X	X	X	X	X	X	X	○	X	X	X	X	
ESC GS x D	X	X	X	X	X	X	X	X	X	○	X	X	X	X	
ESC GS x P	X	X	X	X	X	X	X	X	X	○	X	X	X	X	
ESC GS x I	X	X	X	X	X	X	X	X	X	○	X	X	X	X	

## • Star Original Print Starting Trigger Control Commands

Commands	Model Name														
	TSP700	TSP600	TSP800	TUP900	TSP1000	TSP700II	TSP650	TUP500	TSP800II	FVP10	BSC10	TSP043	TSP650II	TSP650IIISK	
ESC GS g 0	X	X	X	X	X	X	X	X	X	○	X	X	X	X	
ESC GS g 1	X	X	X	X	X	X	X	X	X	○	X	X	X	X	

## • Star Original QR Commands

Commands	Model Name														
	TSP700	TSP600	TSP800	TUP900	TSP1000	TSP700II	TSP650	TUP800	TSP800II	FVP10	BSC10	TSP043	TSP650II	TSP650IIISK	
ESC GS y S 0	X	X	X	X	X	X	X	X	X	○	X	X	X	X	
ESC GS y S 1	X	X	X	X	X	X	X	X	X	○	X	X	X	X	
ESC GS y S 2	X	X	X	X	X	X	X	X	X	○	X	X	X	X	
ESC GS y D 1	X	X	X	X	X	X	X	X	X	○	X	X	X	X	
ESC GS y D 2	X	X	X	X	X	X	X	X	X	○	X	X	X	X	
ESC GS y P	X	X	X	X	X	X	X	X	X	○	X	X	X	X	
ESC GS y I	X	X	X	X	X	X	X	X	X	○	X	X	X	X	

## • Star Original Page Function Commands

Commands	Model Name														
	TSP700	TSP600	TSP800	TUP900	TSP1000	TSP700II	TSP650	TUP500	TSP800II	FVP10	BSC10	TSP043	TSP650II	TSP650IIISK	
ESC GS h 0	X	X	X	X	X	X	X	X	X	○	X	X	X	X	
ESC GS h 1	X	X	X	X	X	X	X	X	X	○	X	X	X	X	

## • Star Original Reduced Printing Function Command

Commands	Model Name														
	TSP700	TSP600	TSP800	TUP900	TSP1000	TSP700II	TSP650	TUP500	TSP800II	FVP10	BSC10	TSP043	TSP650II	TSP650IIISK	
ESC GS c	X	X	X	X	X	X	X	X	X	○	X	X	X	X	

## • Star Original Text Search Commands

Commands	Model Name													
	TSP700	TSP600	TSP800	TUP900	TSP1000	TSP700II	TSP650	TUP500	TSP800II	FVP10	BSC10	TSP043	TSP650II	TSP650IIISK
ESC GS ) B (fn = 48)	X	X	X	X	X	X	X	X	X	○	X	X	X	X
ESC GS ) B (fn = 49)	X	X	X	X	X	X	X	X	X	○	X	X	X	X
ESC GS ) B (fn = 50)	X	X	X	X	X	X	X	X	X	○	X	X	X	X
ESC GS ) B (fn = 64)	X	X	X	X	X	X	X	X	X	○	X	X	X	X
ESC GS ) B (fn = 65)	X	X	X	X	X	X	X	X	X	○	X	X	X	X
ESC GS ) B (fn = 66)	X	X	X	X	X	X	X	X	X	X	X	X	X	X
ESC GS ) B (fn = 80)	X	X	X	X	X	X	X	X	X	○	X	X	X	X
ESC GS ) B (fn = 81)	X	X	X	X	X	X	X	X	X	○	X	X	X	X
ESC GS ) B (fn = 96)	X	X	X	X	X	X	X	X	X	○	X	X	X	X
ESC GS ) B (fn = 97)	X	X	X	X	X	X	X	X	X	○	X	X	X	X

## • Star Original Printer Information Transmission Command

Commands	Model Name													
	TSP700	TSP600	TSP800	TUP900	TSP1000	TSP700II	TSP650	TUP500	TSP800II	FVP10	BSC10	TSP043	TSP650II	TSP650IIISK
ESC GS ) I (fn = 48)	X	X	X	X	X	X	X	X	X	X	X	X	X	X

## • Star Original Individual Logo Command

Commands	Model Name													
	TSP700	TSP600	TSP800	TUP900	TSP1000	TSP700II	TSP650	TUP500	TSP800II	FVP10	BSC10	TSP043	TSP650II	TSP650IIISK
ESC GS ) L (fn = 48)	X	X	X	X	X	X	X	X	X	X	X	X	X	X
ESC GS ) L (fn = 49)	X	X	X	X	X	X	X	X	X	X	X	X	X	X
ESC GS ) L (fn = 50)	X	X	X	X	X	X	X	X	X	X	X	X	X	X

## • Star Original Audio Commands

Commands	Model Name													
	TSP700	TSP600	TSP800	TUP900	TSP1000	TSP700II	TSP650	TUP500	TSP800II	FVP10	BSC10	TSP043	TSP650II	TSP650IIISK
ESC GS s O	X	X	X	X	X	X	X	X	X	○	X	X	X	X
ESC GS s P	X	X	X	X	X	X	X	X	X	○	X	X	X	X
ESC GS s R	X	X	X	X	X	X	X	X	X	○	X	X	X	X
ESC GS s I	X	X	X	X	X	X	X	X	X	○	X	X	X	X
ESC GS s U	X	X	X	X	X	X	X	X	X	○	X	X	X	X
ESC GS s T	X	X	X	X	X	X	X	X	X	○	X	X	X	X

## • Star Original Hold print control Command

Commands	Model Name													
	TSP700	TSP600	TSP800	TUP900	TSP1000	TSP700II	TSP650	TUP500	TSP800II	FVP10	BSC10	TSP043	TSP650II	TSP650IIISK
ESC SYN DC3	X	X	X	X	X	X	X	X	X	X	X	X	X	X
ESC SYN DC4	X	X	X	X	X	X	X	X	X	X	X	X	X	X
ESC GS ) s	X	X	X	X	X	X	X	X	X	X	X	X	X	X

## 7-6 Ethernet I/F

### • Standard Commands

Commands	Model Name													
	TSP700	TSP600	TSP800	TUP900	TSP1000	TSP700II	TSP650	TUP500	TSP800II	FVP10	BSC10	TSP043	TSP650II	TSP650ISK
HT	X	X	X	X	o	o	o	o	o	o	o	o	o	o
LF	X	X	X	X	o	o	o	o	o	o	o	o	o	o
FF	X	X	X	X	o	o	o	o	o	o	o	o	o	o
CR	X	X	X	X	X	X	X	X	X	X	X	X	X	X
CAN	X	X	X	X	o	o	o	o	o	o	o	o	o	o
DLE EOT	X	X	X	X	Spec. B	Spec. B-1 Ver. 1.4 or older Spec. B-2 Ver. 2.0 or later	Spec. B-1 Ver. 1.4 or older Spec. B-2 Ver. 2.0 or later	Spec. B-1 Ver. 1.0 or older Spec. B-2 Ver. 2.0 or later	Spec. B-2	Spec. B-2	Spec. B-2	Spec. B-2	Spec. B-2	Spec. B-2
DLE ENQ	X	X	X	X	X	X	X	X	X	X	X	X	X	X
DLE DC4	X	X	X	X	X	o	o	X	o	o	o	o	o	o
ESC FF	X	X	X	X	o	o	o	o	o	o	o	o	o	o
ESC SP	X	X	X	X	o	o	o	o	o	o	o	o	o	o
ESC !	X	X	X	X	o	o	o	o	o	o	o	o	o	o
ESC \$	X	X	X	X	o	o	o	o	o	o	o	o	o	o
ESC %	X	X	X	X	o	o	o	o	o	o	o	o	o	o
ESC &	X	X	X	X	o	o	o	o	o	o	o	o	o	o
ESC *	X	X	X	X	Spec.A	Spec.A	Spec.A	Spec.A	Spec.A	Spec.A	Spec.A	Spec.A	Spec.B	Spec.B
ESC -	X	X	X	X	o	o	o	o	o	o	o	o	o	o
ESC 2	X	X	X	X	o	o	o	o	o	o	o	o	o	o
ESC 3	X	X	X	X	o	o	o	o	o	o	o	o	o	o
ESC =	X	X	X	X	X	o	o	o	o	o	o	o	o	o
ESC ?	X	X	X	X	o	o	o	o	o	o	o	o	o	o
ESC @	X	X	X	X	o	o	o	o	o	o	o	o	o	o
ESC D	X	X	X	X	o	o	o	o	o	o	o	o	o	o
ESC E	X	X	X	X	o	o	o	o	o	o	o	o	o	o
ESC G	X	X	X	X	o	o	o	o	o	o	o	o	o	o
ESC J	X	X	X	X	o	o	o	o	o	o	o	o	o	o
ESC L	X	X	X	X	o	o	o	o	o	o	o	o	o	o
ESC M	X	X	X	X	o	o	o	o	o	o	o	o	o	o
ESC R	X	X	X	X	Spec.A	Spec.A	Spec.A	Spec.A	Spec.A	Spec.A	Spec.A Ver.1.0 to 1.2 Spec.B Ver.1.3 or later	Spec.A Ver.1.0 to 1.2 Spec.B Ver.1.3 or later	Spec.B	Spec.B
ESC S	X	X	X	X	o	o	o	o	o	o	o	o	o	o
ESC T	X	X	X	X	o	o	o	o	o	o	o	o	o	o
ESC V	X	X	X	X	o	o	o	o	o	o	o	o	o	o
ESC W	X	X	X	X	o	o	o	o	o	o	o	o	o	o
ESC \	X	X	X	X	o	o	o	o	o	o	o	o	o	o
ESC a	X	X	X	X	o	o	o	o	o	o	o	o	o	o
ESC c 3	X	X	X	X	X	X	X	X	X	X	X	X	X	X
ESC c 4	X	X	X	X	o	o	o	o	o	o	o	o	o	o
ESC c 5	X	X	X	X	o	o	o	o	o	o	o	o	o	o
ESC d	X	X	X	X	o	o	o	o	o	o	o	o	o	o
ESC p	X	X	X	X	X	o	o	o	o	o	o	o	o	o
ESC t	X	X	X	X	Spec.A	Spec.A	Spec.A	Spec.A	Spec.A	Spec.A	Spec.B	Spec.B	Spec.B	Spec.B
ESC {	X	X	X	X	o	o	o	o	o	o	o	o	o	o
FS g 1	X	X	X	X	X	X	X	X	X	X	X	X	X	X
FS g 2	X	X	X	X	X	X	X	X	X	X	X	X	X	X
FS p	X	X	X	X	o	o	o	o	o	o	o	o	o	o



Commands	Model Name														
	TSP700	TSP600	TSP800	TUP900	TSP1000	TSP700II	TSP650	TUP500	TSP800II	FVP10	BSC10	TSP043	TSP650II	TSP650IISK	
FS q	X	X	X	X	o	o	o	o	o	o	o	o	o	o	
GS !	X	X	X	X	o	o	o	o	o	o	o	o	o	o	
GS \$	X	X	X	X	o	o	o	o	o	o	o	o	o	o	
GS *	X	X	X	X	o	o	o	o	o	o	o	o	o	o	
GS ( A	X	X	X	X	o	o	o	o	o	o	o	o	o	o	
GS ( K (fn=49)	X	X	X	X	Spec.A	Spec.A	Spec.A	Spec.A	Spec.B	Spec.B	Spec.C	Spec.C	Spec.C	X	
GS ( K (fn=50)	X	X	X	X	X	X	X	X	X	X	Spec.A	Spec.A	Spec.A	Spec.B	
GS ( L (fn=48)	X	X	X	X	X	X	X	X	X	X	o	o	o	o	
GS ( L (fn=51)	X	X	X	X	X	X	X	X	X	X	o	o	o	o	
GS ( L (fn=64)	X	X	X	X	X	X	X	X	X	X	o	o	o	o	
GS ( L (fn=65)	X	X	X	X	X	X	X	X	X	X	o	o	o	o	
GS ( L (fn=66)	X	X	X	X	X	X	X	X	X	X	o	o	o	o	
GS ( L (fn=67)	X	X	X	X	X	X	X	X	X	X	o	o	o	o	
GS ( L (fn=69)	X	X	X	X	X	X	X	X	X	X	o	o	o	o	
GS ( L (fn=112)	X	X	X	X	X	Ver 2.0 or later	Ver 2.0 or later	o	o	o	o	o	o	o	
GS 8 L (fn=48)	X	X	X	X	X	X	X	X	X	X	o	o	o	o	
GS 8 L (fn=51)	X	X	X	X	X	X	X	X	X	X	o	o	o	o	
GS 8 L (fn=64)	X	X	X	X	X	X	X	X	X	X	o	o	o	o	
GS 8 L (fn=65)	X	X	X	X	X	X	X	X	X	X	o	o	o	o	
GS 8 L (fn=66)	X	X	X	X	X	X	X	X	X	X	o	o	o	o	
GS 8 L (fn=67)	X	X	X	X	X	X	X	X	X	X	o	o	o	o	
GS 8 L (fn=69)	X	X	X	X	X	X	X	X	X	X	o	o	o	o	
GS 8 L (fn=112)	X	X	X	X	X	Ver2.0 or later	Ver2.0 or later	o	o	o	o	o	o	o	
GS ( N	X	X	X	X	o	o	o	o	o	o	X	X	o	o	
GS ( k (cn=48,fn=65)	x	x	x	x	x	x	x	x	x	x	o	o	o	o	
GS ( k (cn=48,fn=66)	x	x	x	x	x	x	x	x	x	x	o	o	o	o	
GS ( k (cn=48,fn=67)	x	x	x	x	x	x	x	x	x	x	o	o	o	o	
GS ( k (cn=48,fn=68)	x	x	x	x	x	x	x	x	x	x	o	o	o	o	
GS ( k (cn=48,fn=69)	x	x	x	x	x	x	x	x	x	x	o	o	o	o	
GS ( k (cn=48,fn=70)	x	x	x	x	x	x	x	x	x	x	o	o	o	o	
GS ( k (cn=48,fn=80)	x	x	x	x	x	x	x	x	x	x	o	o	o	o	
GS ( k (cn=48,fn=81)	x	x	x	x	x	x	x	x	x	x	o	o	o	o	
GS ( k (cn=48,fn=82)	x	x	x	x	x	x	x	x	x	x	o Ver. 1.3 or older x Ver.1.4 or later	o Ver. 1.2 or older x Ver.1.4 or later	o Ver. 1.2 or older x Ver.2.0 or later	x	
GS ( k (cn=49,fn=65)	x	x	x	x	x	x	x	x	x	x	o	o	o	o	
GS ( k (cn=49,fn=67)	x	x	x	x	x	x	x	x	x	x	o	o	o	o	
GS ( k (cn=49,fn=69)	x	x	x	x	x	x	x	x	x	x	o	o	o	o	
GS ( k (cn=49,fn=80)	x	x	x	x	x	x	x	x	x	x	o	o	o	o	
GS ( k (cn=49,fn=81)	x	x	x	x	x	x	x	x	x	x	o	o	o	o	
GS ( k (cn=49,fn=82)	x	x	x	x	x	x	x	x	x	x	o Ver. 1.3 or older x Ver.1.4 or later	o Ver. 1.2 or older x Ver.1.4 or later	o Ver. 1.2 or older x Ver.2.0 or later	x	
GS ( k (cn=51,fn=67)	x	x	x	x	x	x	x	x	x	x	x	x	Ver.2.0 or later	o	
GS ( k (cn=51,fn=71)	x	x	x	x	x	x	x	x	x	x	x	x	Ver.2.0 or later	o	

Commands	Model Name													
	TSP700	TSP600	TSP800	TUP900	TSP1000	TSP700II	TSP650	TUP500	TSP800II	FVP10	BSC10	TSP043	TSP650II	TSP650IIISK
GS ( k (cn=51,fn=80)	x	x	x	x	x	x	x	x	x	x	x	x	Ver.2.0 or later	o
GS ( k (cn=51,fn=81)	x	x	x	x	x	x	x	x	x	x	x	x	Ver.2.0 or later	o
GS ( k (cn=52,fn=67)	x	x	x	x	x	x	x	x	x	x	x	x	Ver.2.0 or later	o
GS ( k (cn=52,fn=71)	x	x	x	x	x	x	x	x	x	x	x	x	Ver.2.0 or later	o
GS ( k (cn=52,fn=72)	x	x	x	x	x	x	x	x	x	x	x	x	Ver.2.0 or later	o
GS ( k (cn=52,fn=80)	x	x	x	x	x	x	x	x	x	x	x	x	Ver.2.0 or later	o
GS ( k (cn=52,fn=81)	x	x	x	x	x	x	x	x	x	x	x	x	Ver.2.0 or later	o
GS /	X	X	X	X	o	o	o	o	o	o	o	o	o	o
GS :	X	X	X	X	o	o	o	o	o	o	o	o	o	o
GS B	X	X	X	X	o	o	o	o	o	o	o	o	o	o
GS C 0	X	X	X	X	o	o	o	o	o	o	X	X	o	o
GS C 1	X	X	X	X	o	o	o	o	o	o	X	X	o	o
GS C 2	X	X	X	X	o	o	o	o	o	o	X	X	o	o
GS C ;	X	X	X	X	o	o	o	o	o	o	X	X	o	o
GS E	X	X	X	X	Spec. A	Spec. A	Spec. A	Spec. A	Spec. A	Spec. A	X	X	Spec. A	Spec. B
GS H	X	X	X	X	o	o	o	o	o	o	o	o	o	o
GS I	X	X	X	X	Spec. A	Spec. A Ver. 3.0 or older Spec. B Ver. 3.1 or later	Spec. A Ver. 3.0 or older Spec. B Ver. 3.1 or later	Spec. A Ver. 3.2 or older Spec. B Ver. 3.3 or later	Spec. A	Spec. B	Spec. B	Spec. B	Spec. B	Spec. B
GS L	X	X	X	X	o	o	o	o	o	o	o	o	o	o
GS P	X	X	X	X	X	o	o	X	o	o	o	o	o	o
GS T	X	X	X	X	o	o	o	o	o	o	o	o	o	o
GS V	X	X	X	X	o	o	o	o	o	o	o	o	o	o
GS W	X	X	X	X	o	o	o	o	o	o	o	o	o	o
GS \	X	X	X	X	o	o	o	o	o	o	o	o	o	o
GS ^	X	X	X	X	o	o	o	o	o	o	o	o	o	o
GS b	X	X	X	X	X	X	X	X	X	X	Ver.1.3 or later	Ver.1.3 or later	o	o
GS c	X	X	X	X	o	o	o	o	o	o	X	X	o	o
GS f	X	X	X	X	o	o	o	o	o	o	o	o	o	o
GS h	X	X	X	X	o	o	o	o	o	o	o	o	o	o
GS k	X	X	X	X	Spec. A Spec. B	Spec. A Spec. B	Spec. A Spec. B	Spec. A Spec. B	Spec. A Spec. B	Spec. A Spec. B	Spec. A Spec. B	Spec. A Spec. B	Spec. A: Ver. 1.2 or older Spec. A,B,C: Ver.2.0 or later	Spec. A,B,C
GS r	X	X	X	X	o	o	o	o	o	o	o	o	o	o
GS v 0	X	X	X	X	o	o	o	o	o	o	o	o	o	o
GS w	X	X	X	X	o	o	o	o	o	o	o	o	o	o

## • Kanji Control Commands (DBCS Settings, Kanji Specifications Only)

Commands	Model Name													
	TSP700	TSP600	TSP800	TUP900	TSP1000	TSP700II	TSP650	TUP500	TSP800II	FVP10	BSC10	TSP043	TSP650II	TSP650II SK
FS !	X	X	X	X	○	○	○	○	○	○	○	○	○	○
FS &	X	X	X	X	Spec. A	Spec. A	Spec. A	Spec. A	Spec. A	Spec. A	Spec. B	Spec. B	Spec. A	Spec. A
FS -	X	X	X	X	○	○	○	○	○	○	○	○	○	○
FS .	X	X	X	X	○	○	○	○	○	○	○	○	○	○
FS 2	X	X	X	X	○	○	○	○	○	○	○	○	○	○
FS C	X	X	X	X	○	○	○	○	○	○	X	X	○	○
FS S	X	X	X	X	○	○	○	○	○	○	○	○	○	○
FS W	X	X	X	X	○	○	○	○	○	○	○	○	○	○

## • ESC/POS Black Mark Related Commands (When black marks are effective)

Commands	Model Name													
	TSP700	TSP600	TSP800	TUP900	TSP1000	TSP700II	TSP650	TUP500	TSP800II	FVP10	BSC10	TSP043	TSP650II	TSP650II SK
FF	X	X	X	X	○	○	X	○	○	○	○	○	X	X
DLE ENQ	X	X	X	X	○	○	X	○	○	○	○	○	X	X
GS FF	X	X	X	X	○	○	X	○	○	○	○	○	X	X
GS ( F	X	X	X	X	○	X	X	X	X	X	X	X	X	X
GS ( M n=1	X	X	X	X	○	X	X	X	X	X	X	X	X	X
GS ( M n=2	X	X	X	X	○	X	X	X	X	X	X	X	X	X
GS ( M n=3	X	X	X	X	○	X	X	X	X	X	X	X	X	X
GS <	X	X	X	X	X	○	X	X	○	○	○	○	X	X
GS V	X	X	X	X	○	○	X	○	○	○	○	○	X	X

## • STAR Original Commands

Commands	Model Name													
	TSP700	TSP600	TSP800	TUP900	TSP1000	TSP700II	TSP650	TUP500	TSP800II	FVP10	BSC10	TSP043	TSP650II	TSP650II SK
ESC GS =	X	X	X	X	○	○	○	○	○	○	○	○	○	○
ESC GS t	X	X	X	X	Spec. A	Spec. A	Spec. A	Spec. A	Spec. A	Spec. A	Spec. B	Spec. B	Spec. B	Spec. B
ESC GS +	X	X	X	X	X	○	○	○	○	○	○	○	○	○
ESCGS #m	X	X	X	X	Spec. B	Spec. B Ver. 1.0~2.0 Spec. C Ver. 3.0 or later	Spec. B Ver. 1.0~2.0 Spec. C Ver. 3.0 or later	Spec. B Ver. 1.0~2.0 Spec. C Ver. 3.0 or later	Spec. C	Spec. C	Spec. C	Spec. C	Spec. C	Spec. C
ESCRSF	X	X	X	X	○	○	○	○	○	○	○	○	○	○
ESCRSC	X	X	X	X	X	○	○	○	○	○	X	X	○	X
ESCRSL	X	X	X	X	X	Spec. A Ver. 1.3~1.4 Spec. B Ver. 2.0 or later	Spec. A Ver. 1.0~1.4 Spec. B Ver. 2.0 or later	Spec. B	Spec. B	Spec. B	Spec. B	Spec. B	Spec. B	Spec. B
ESCGSETX	X	X	X	X	X	Spec. A Ver. 2.0 or later Spec. B Ver. 3.0 or later	Spec. A Ver. 2.0 or later Spec. B Ver. 3.0 or later	Spec. A Ver. 2.0 or later Spec. B Ver. 3.0 or later	Spec. A Ver. 1.0	Spec. B	Spec. B	Spec. B	Spec. B	Spec. B

## • STAR Original Presenter Control Commands

Commands	Model Name														
	TSP700	TSP600	TSP800	TUP900	TSP1000	TSP700II	TSP650	TUP500	TSP800II	FVP10	BSC10	TSP043	TSP650II	TSP650IIISK	
ESC SYN 0	X	X	X	X	X	X	X	○	X	X	X	X	X	X	
ESC SYN 1	X	X	X	X	X	X	X	○	X	X	X	X	X	X	
ESC SYN 3	X	X	X	X	X	X	X	○	X	X	X	X	X	X	
ESC SYN 4	X	X	X	X	X	X	X	○	X	X	X	X	X	X	
ESC GS SUB DC1	X	X	X	X	X	X	X	○	X	X	X	X	X	X	
ESC GS SUB DC2	X	X	X	X	X	X	X	○	X	X	X	X	X	X	
ESC GS SUB DC3	X	X	X	X	X	X	X	○	X	X	X	X	X	X	

## • Star Original Mark Commands

Commands	Model Name														
	TSP700	TSP600	TSP800	TUP900	TSP1000	TSP700II	TSP650	TUP500	TSP800II	FVP10	BSC10	TSP043	TSP650II	TSP650IIISK	
ESC GS * 0	X	X	X	X	○	○	○	○	○	○	○	○	○	○	
ESC GS * 1	X	X	X	X	○	○	○	○	○	○	○	○	○	○	
ESC GS * 2	X	X	X	X	○	○	○	○	○	○	○	○	○	○	
ESCGS * W	X	X	X	X	○	○	○	○	○	○	○	○	○	○	
ESC GS * C	X	X	X	X	○	○	○	○	○	○	○	○	○	○	

## • STAR Original Auto Logo Commands

Commands	Model Name														
	TSP700	TSP600	TSP800	TUP900	TSP1000	TSP700II	TSP650	TUP500	TSP800II	FVP10	BSC10	TSP043	TSP650II	TSP650IIISK	
ESCGS / W	X	X	X	X	X	○	○	X	○	○	Ver1.3 or later	Ver1.3 or later	○	○	
ESC GS / C	X	X	X	X	X	○	○	X	○	○	Ver1.3 or later	Ver1.3 or later	○	○	
ESC GS / 1	X	X	X	X	X	○	○	X	○	○	Ver1.3 or later	Ver1.3 or later	○	○	
ESC GS / 2	X	X	X	X	X	○	○	X	○	○	Ver1.3 or later	Ver1.3 or later	○	○	
ESC GS / 3	X	X	X	X	X	○	○	X	○	○	Ver1.3 or later	Ver1.3 or later	○	○	
ESC GS / 4	X	X	X	X	X	○	○	X	○	○	Ver1.3 or later	Ver1.3 or later	○	○	
ESC GS / 5	X	X	X	X	X	○	○	X	○	○	Ver1.3 or later	Ver1.3 or later	○	○	
ESC GS / 6	X	X	X	X	X	○	○	X	○	○	Ver1.3 or later	Ver1.3 or later	○	○	

## • Star Original Buzzer Commands

Commands	Model Name														
	TSP700	TSP600	TSP800	TUP900	TSP1000	TSP700II	TSP650	TUP500	TSP800II	FVP10	BSC10	TSP043	TSP650II	TSP650IIISK	
ESC GS BEL	X	X	X	X	○	○	○	X	○	○	○	○	○	○	
ESC GS EM DC1	X	X	X	X	X	Ver1.3 or later	○	X	○	○	○	○	○	○	
ESC GS EM DC2	X	X	X	X	X	Ver1.3 or later	○	X	○	○	○	○	○	○	

## • Star Original PDF417 Commands

Commands	Model Name														
	TSP700	TSP600	TSP800	TUP900	TSP1000	TSP700II	TSP650	TUP500	TSP800II	FVP10	BSC10	TSP043	TSP650II	TSP650IIISK	
ESC GS x S 0	X	X	X	X	○	○	X	○	○	○	X	X	X	X	
ESC GS x S 1	X	X	X	X	○	○	X	○	○	○	X	X	X	X	
ESC GS x S 2	X	X	X	X	○	○	X	○	○	○	X	X	X	X	
ESC GS x S 3	X	X	X	X	○	○	X	○	○	○	X	X	X	X	
ESC GS x D	X	X	X	X	○	○	X	○	○	○	X	X	X	X	
ESC GS x P	X	X	X	X	○	○	X	○	○	○	X	X	X	X	
ESC GS x I	X	X	X	X	○	○ Ver 5.1 or earlier x Ver 6.0 or later	X	○ Ver 4.2 or earlier x Ver 6.0 or later	○ Ver 2.1 or earlier x Ver 6.0 or later	○	X	X	X	X	

## • Star Original Print Starting Trigger Control Commands

Commands	Model Name														
	TSP700	TSP600	TSP800	TUP900	TSP1000	TSP700II	TSP650	TUP500	TSP800II	FVP10	BSC10	TSP043	TSP650II	TSP650IIISK	
ESC GS g 0	X	X	X	X	Ver1.1 or later	○	○	○	○	○	○	○	○	○	
ESC GS g 1	X	X	X	X	Ver1.1 or later	○	○	○	○	○	○	○	○	○	

## • Star Original QR Commands

Commands	Model Name														
	TSP700	TSP600	TSP800	TUP900	TSP1000	TSP700II	TSP650	TUP800	TSP800II	FVP10	BSC10	TSP043	TSP650II	TSP650IIISK	
ESC GS y S 0	X	X	X	X	Ver1.2 or later	○	X	○	○	○	X	X	X	X	
ESC GS y S 1	X	X	X	X	Ver1.2 or later	○	X	○	○	○	X	X	X	X	
ESC GS y S 2	X	X	X	X	Ver1.2 or later	○	X	○	○	○	X	X	X	X	
ESC GS y D 1	X	X	X	X	Ver1.2 or later	○	X	○	○	○	X	X	X	X	
ESC GS y D 2	X	X	X	X	Ver1.2 or later	○	X	○	○	○	X	X	X	X	
ESC GS y P	X	X	X	X	Ver1.2 or later	○	X	○	○	○	X	X	X	X	
ESC GS y I	X	X	X	X	Ver1.2 or later	○ Ver 5.1 or earlier x Ver 6.0 or later	X	○	○	○	X	X	X	X	

• Star Original Page Function Commands

Commands	Model Name													
	TSP700	TSP600	TSP800	TUP900	TSP1000	TSP700II	TSP650	TUP500	TSP800II	FVP10	BSC10	TSP043	TSP650II	TSP650IIISK
ESC GS h 0	X	X	X	X	X	○	○	○	○	○	○	○	○	○
ESC GS h 1	X	X	X	X	X	○	○	○	○	○	Ver.1.3 or later	Ver.1.3 or later	○	○

• Star Original Reduced Printing Function Command

Commands	Model Name													
	TSP700	TSP600	TSP800	TUP900	TSP1000	TSP700II	TSP650	TUP500	TSP800II	FVP10	BSC10	TSP043	TSP650II	TSP650IIISK
ESC GS C	X	X	X	X	X	X	X	X	X	○	○	○	X	X

Star Original Text Search Commands

Commands	Model Name													
	TSP700	TSP600	TSP800	TUP900	TSP1000	TSP700II	TSP650	TUP500	TSP800II	FVP10	BSC10	TSP043	TSP650II	TSP650IIISK
ESC GS ) B (fn = 48)	X	X	X	X	X	X	X	X	X	○	○	○	○	○
ESC GS ) B (fn = 49)	X	X	X	X	X	X	X	X	X	○	○	○	○	○
ESC GS ) B (fn = 50)	X	X	X	X	X	X	X	X	X	○	○	○	○	○
ESC GS ) B (fn = 64)	X	X	X	X	X	X	X	X	X	○	○	○	○	○
ESC GS ) B (fn = 65)	X	X	X	X	X	X	X	X	X	○	○	○	○	○
ESC GS ) B (fn = 66)	X	X	X	X	X	X	X	X	X	X	Ver.1.3 or later	Ver.1.3 or later	○	○
ESC GS ) B (fn = 80)	X	X	X	X	X	X	X	X	X	○	○	○	○	○
ESC GS ) B (fn = 81)	X	X	X	X	X	X	X	X	X	○	○	○	○	○
ESC GS ) B (fn = 96)	X	X	X	X	X	X	X	X	X	○	○	○	○	○
ESC GS ) B (fn = 97)	X	X	X	X	X	X	X	X	X	○	○	○	○	○

• Star Original Printer Information Transmission Command

Commands	Model Name													
	TSP700	TSP600	TSP800	TUP900	TSP1000	TSP700II	TSP650	TUP500	TSP800II	FVP10	BSC10	TSP043	TSP650II	TSP650IIISK
ESC GS ) I (fn = 48)	X	X	X	X	X	X	X	X	X	X	Ver.1.3 or later	Ver.1.3 or later	○	○

• Star Original Individual Logo Command

Commands	Model Name													
	TSP700	TSP600	TSP800	TUP900	TSP1000	TSP700II	TSP650	TUP500	TSP800II	FVP10	BSC10	TSP043	TSP650II	TSP650IIISK
ESC GS ) L (fn = 48)	X	X	X	X	X	X	X	X	X	X	○	○	○	○
ESC GS ) L (fn = 49)	X	X	X	X	X	X	X	X	X	X	Ver.1.3 or later	Ver.1.3 or later	○	○
ESC GS ) L (fn = 50)	X	X	X	X	X	X	X	X	X	X	Ver.1.3 or later Spec.A	Ver.1.3 or later Spec.A	Spec. B	Spec. B

## • Star Original Audio Commands

Commands	Model Name													
	TSP700	TSP600	TSP800	TUP900	TSP1000	TSP700II	TSP650	TUP500	TSP800II	FVP10	BSC10	TSP043	TSP650II	TSP650IIISK
ESC GS s O	X	X	X	X	X	X	X	X	X	○	X	X	X	X
ESC GS s P	X	X	X	X	X	X	X	X	X	○	X	X	X	X
ESC GS s R	X	X	X	X	X	X	X	X	X	○	X	X	X	X
ESC GS s I	X	X	X	X	X	X	X	X	X	○	X	X	X	X
ESC GS s U	X	X	X	X	X	X	X	X	X	○	X	X	X	X
ESC GS s T	X	X	X	X	X	X	X	X	X	○	X	X	X	X

## • Star Original Hold print control Command

Commands	Model Name													
	TSP700	TSP600	TSP800	TUP900	TSP1000	TSP700II	TSP650	TUP500	TSP800II	FVP10	BSC10	TSP043	TSP650II	TSP650IIISK
ESC SYN DC3	X	X	X	X	X	X	X	X	X	X	X	X	X	○
ESC SYN DC4	X	X	X	X	X	X	X	X	X	X	X	X	X	○
ESC GS )s	X	X	X	X	X	X	X	X	X	X	X	X	X	○

## • Ethernet I/F Status Specifications

Commands	Model Name													
	TSP700	TSP600	TSP800	TUP900	TSP1000	TSP700II	TSP650	TUP500	TSP800II	FVP10	BSC10	TSP043	TSP650II	TSP650IIISK
Status Specifications for Ethernet I/F	X	X	X	X	Spec. A	To Ver. 1.4 Spec. A From Ver. 2.0 Spec. B	To Ver. 1.4 Spec. A From Ver. 2.0 Spec. B	Ver. 1.0 Spec. A From Ver. 2.0 Spec. B	Spec. B	Spec. B	Spec. B	Spec. B	Spec. B	Spec. B

- (\*1) The following is the status of support for Ethernet I/F.  
 Affected by the combination with the following Ethernet I/F (F/W versions).
- IFBD-HE05/06 F/W Version (Main) Ver. 1.0.1: Command Invalid
  - IFBD-HE05/06 F/W Version (Main) Ver. 1.1.0: Command Enabled

## 7-7 Wireless LAN I/F

### • Standard Commands

Commands	Model Name													
	TSP700	TSP600	TSP800	TUP900	TSP1000	TSP700II	TSP650	TUP500	TSP800II	FVP10	BSC10	TSP043	TSP650II	TSP650IIISK
HT	○	X	○	X	○	○	X	X	X	X	X	X	X	X
LF	○	X	○	X	○	○	X	X	X	X	X	X	X	X
FF	○	X	○	X	○	○	X	X	X	X	X	X	X	X
CR	○	X	○	X	X	X	X	X	X	X	X	X	X	X
CAN	○	X	○	X	○	○	X	X	X	X	X	X	X	X
DLE EOT	Spec. A	X	Spec. A	X	Spec. B	Spec. B-1 Ver. 1.4 or older Spec. B-2 Ver. 2.0 or later	X	X	X	X	X	X	X	X
DLE ENQ	X	X	X	X	X	X	X	X	X	X	X	X	X	X
DLE DC4	○	X	○	X	X	○	X	X	X	X	X	X	X	X
ESC FF	○	X	○	X	○	○	X	X	X	X	X	X	X	X
ESC SP	○	X	○	X	○	○	X	X	X	X	X	X	X	X
ESC !	○	X	○	X	○	○	X	X	X	X	X	X	X	X
ESC \$	○	X	○	X	○	○	X	X	X	X	X	X	X	X
ESC %	○	X	○	X	○	○	X	X	X	X	X	X	X	X
ESC &	○	X	○	X	○	○	X	X	X	X	X	X	X	X
ESC *	Spec.A	X	Spec.A	X	Spec.A	Spec.A	X	X	X	X	X	X	X	X
ESC -	○	X	○	X	○	○	X	X	X	X	X	X	X	X
ESC 2	○	X	○	X	○	○	X	X	X	X	X	X	X	X
ESC 3	○	X	○	X	○	○	X	X	X	X	X	X	X	X
ESC =	○	X	○	X	X	○	X	X	X	X	X	X	X	X
ESC ?	○	X	○	X	○	○	X	X	X	X	X	X	X	X
ESC @	○	X	○	X	○	○	X	X	X	X	X	X	X	X
ESC D	○	X	○	X	○	○	X	X	X	X	X	X	X	X
ESC E	○	X	○	X	○	○	X	X	X	X	X	X	X	X
ESC G	○	X	○	X	○	○	X	X	X	X	X	X	X	X
ESC J	○	X	○	X	○	○	X	X	X	X	X	X	X	X
ESC L	○	X	○	X	○	○	X	X	X	X	X	X	X	X
ESC M	○	X	○	X	○	○	X	X	X	X	X	X	X	X
ESC R	Spec.A	X	Spec.A	X	Spec.A	Spec.A	X	X	X	X	X	X	X	X
ESC S	○	X	○	X	○	○	X	X	X	X	X	X	X	X
ESC T	○	X	○	X	○	○	X	X	X	X	X	X	X	X
ESC V	○	X	○	X	○	○	X	X	X	X	X	X	X	X
ESC W	○	X	○	X	○	○	X	X	X	X	X	X	X	X
ESC \	○	X	○	X	○	○	X	X	X	X	X	X	X	X
ESC a	○	X	○	X	○	○	X	X	X	X	X	X	X	X
ESC c 3	Spec.Bar Ver.4.0 or later	X	Spec.Bar Ver.5.0 or later	X	X	X	X	X	X	X	X	X	X	X
ESC c 4	○	X	○	X	○	○	X	X	X	X	X	X	X	X
ESC c 5	○	X	○	X	○	○	X	X	X	X	X	X	X	X
ESC d	○	X	○	X	○	○	X	X	X	X	X	X	X	X
ESC p	○	X	○	X	X	○	X	X	X	X	X	X	X	X
ESC t	Spec.A	X	Spec.A	X	Spec.A	Spec.A	X	X	X	X	X	X	X	X
ESC {	○	X	○	X	○	○	X	X	X	X	X	X	X	X
FS g 1	X	X	X	X	X	X	X	X	X	X	X	X	X	X
FS g 2	X	X	X	X	X	X	X	X	X	X	X	X	X	X



Commands	Model Name													
	TSP700	TSP600	TSP800	TUP900	TSP1000	TSP700II	TSP650	TUP500	TSP800II	FVP10	BSC10	TSP043	TSP650II	TSP650IIISK
FS p	o	x	o	x	o	o	x	x	x	x	x	x	x	x
FS q	o	x	o	x	o	o	x	x	x	x	x	x	x	x
GS !	o	x	o	x	o	o	x	x	x	x	x	x	x	x
GS \$	o	x	o	x	o	o	x	x	x	x	x	x	x	x
GS *	o	x	o	x	o	o	x	x	x	x	x	x	x	x
GS ( A	o	x	o	x	o	o	x	x	x	x	x	x	x	x
GS ( K	x	x	x	x	Spec.A	Spec.A	x	x	x	x	x	x	x	x
GS ( K (fn=49)	x	x	x	x	Spec.A	Spec.A	x	x	x	x	x	x	x	x
GS ( K (fn=50)	x	x	x	x	x	x	x	x	x	x	x	x	x	x
GS ( L (fn=48)	x	x	x	x	x	x	x	x	x	x	x	x	x	x
GS ( L (fn=51)	x	x	x	x	x	x	x	x	x	x	x	x	x	x
GS ( L (fn=64)	x	x	x	x	x	x	x	x	x	x	x	x	x	x
GS ( L (fn=65)	x	x	x	x	x	x	x	x	x	x	x	x	x	x
GS ( L (fn=66)	x	x	x	x	x	x	x	x	x	x	x	x	x	x
GS ( L (fn=67)	x	x	x	x	x	x	x	x	x	x	x	x	x	x
GS ( L (fn=69)	x	x	x	x	x	x	x	x	x	x	x	x	x	x
GS ( L (fn=112)	x	x	x	x	x	Ver2.0 or later	x	x	x	x	x	x	x	x
GS 8 L (fn=48)	x	x	x	x	x	x	x	x	x	x	x	x	x	x
GS 8 L (fn=51)	x	x	x	x	x	x	x	x	x	x	x	x	x	x
GS 8 L (fn=64)	x	x	x	x	x	x	x	x	x	x	x	x	x	x
GS 8 L (fn=65)	x	x	x	x	x	x	x	x	x	x	x	x	x	x
GS 8 L (fn=66)	x	x	x	x	x	x	x	x	x	x	x	x	x	x
GS 8 L (fn=67)	x	x	x	x	x	x	x	x	x	x	x	x	x	x
GS 8 L (fn=69)	x	x	x	x	x	x	x	x	x	x	x	x	x	x
GS 8 L (fn=112)	x	x	x	x	x	Ver2.0 or later	x	x	x	x	x	x	x	x
GS ( N	x	x	x	x	o	o	x	x	x	x	x	x	x	x
GS ( k (cn=48,fn=65)	x	x	x	x	x	x	x	x	x	x	x	x	x	x
GS ( k (cn=48,fn=66)	x	x	x	x	x	x	x	x	x	x	x	x	x	x
GS ( k (cn=48,fn=67)	x	x	x	x	x	x	x	x	x	x	x	x	x	x
GS ( k (cn=48,fn=68)	x	x	x	x	x	x	x	x	x	x	x	x	x	x
GS ( k (cn=48,fn=69)	x	x	x	x	x	x	x	x	x	x	x	x	x	x
GS ( k (cn=48,fn=70)	x	x	x	x	x	x	x	x	x	x	x	x	x	x
GS ( k (cn=48,fn=80)	x	x	x	x	x	x	x	x	x	x	x	x	x	x
GS ( k (cn=48,fn=81)	x	x	x	x	x	x	x	x	x	x	x	x	x	x
GS ( k (cn=48,fn=82)	x	x	x	x	x	x	x	x	x	x	x	x	x	x
GS ( k (cn=49,fn=65)	x	x	x	x	x	x	x	x	x	x	x	x	x	x
GS ( k (cn=49,fn=67)	x	x	x	x	x	x	x	x	x	x	x	x	x	x
GS ( k (cn=49,fn=69)	x	x	x	x	x	x	x	x	x	x	x	x	x	x
GS ( k (cn=49,fn=80)	x	x	x	x	x	x	x	x	x	x	x	x	x	x
GS ( k (cn=49,fn=81)	x	x	x	x	x	x	x	x	x	x	x	x	x	x
GS ( k (cn=49,fn=82)	x	x	x	x	x	x	x	x	x	x	x	x	x	x
GS ( k (cn=51,fn=67)	x	x	x	x	x	x	x	x	x	x	x	x	x	x
GS ( k (cn=51,fn=71)	x	x	x	x	x	x	x	x	x	x	x	x	x	x
GS ( k (cn=51,fn=80)	x	x	x	x	x	x	x	x	x	x	x	x	x	x
GS ( k (cn=51,fn=81)	x	x	x	x	x	x	x	x	x	x	x	x	x	x
GS ( k (cn=52,fn=67)	x	x	x	x	x	x	x	x	x	x	x	x	x	x
GS ( k (cn=52,fn=71)	x	x	x	x	x	x	x	x	x	x	x	x	x	x
GS ( k (cn=52,fn=72)	x	x	x	x	x	x	x	x	x	x	x	x	x	x
GS ( k (cn=52,fn=80)	x	x	x	x	x	x	x	x	x	x	x	x	x	x
GS ( k (cn=52,fn=81)	x	x	x	x	x	x	x	x	x	x	x	x	x	x

Commands	Model Name													
	TSP700	TSP600	TSP800	TUP900	TSP1000	TSP700II	TSP650	TUP500	TSP800II	FVP10	BSC10	TSP043	TSP650II	TSP650IIISK
GS /	○	X	○	X	○	○	X	X	X	X	X	X	X	X
GS :	○	X	○	X	○	○	X	X	X	X	X	X	X	X
GS B	○	X	○	X	○	○	X	X	X	X	X	X	X	X
GS C 0	X	X	X	X	○	○	X	X	X	X	X	X	X	X
GS C 1	X	X	X	X	○	○	X	X	X	X	X	X	X	X
GS C 2	X	X	X	X	○	○	X	X	X	X	X	X	X	X
GS C ;	X	X	X	X	○	○	X	X	X	X	X	X	X	X
GS E	X	X	X	X	Spec. A	Spec. A	X	X	X	X	X	X	X	X
GS H	○	X	○	X	○	○	X	X	X	X	X	X	X	X
GS I	Spec. A	X	Spec. A	X	Spec. A	Spec. A Ver. 3.0 or older Spec. B Ver. 3.1 or later	X	X	X	X	X	X	X	X
GS L	○	X	○	X	○	○	X	X	X	X	X	X	X	X
GS P	○	X	○	X	X	○	X	X	X	X	X	X	X	X
GS T	X	X	X	X	○	○	X	X	X	X	X	X	X	X
GS V	○	X	○	X	○	○	X	X	X	X	X	X	X	X
GS W	○	X	○	X	○	○	X	X	X	X	X	X	X	X
GS \	○	X	○	X	○	○	X	X	X	X	X	X	X	X
GS ^	○	X	○	X	○	○	X	X	X	X	X	X	X	X
GS b	○	X	○	X	X	X	X	X	X	X	X	X	X	X
GS c	○	X	○	X	○	○	X	X	X	X	X	X	X	X
GS f	X	X	X	X	○	○	X	X	X	X	X	X	X	X
GS h	X	X	X	X	○	○	X	X	X	X	X	X	X	X
GS k	Spec. A,B	X	Spec. A,B	X	Spec. A,B	Spec. A,B	X	X	X	X	X	X	X	X
GS r	○	X	○	X	○	○	X	X	X	X	X	X	X	X
GS v 0	○	X	○	X	○	○	X	X	X	X	X	X	X	X
GS w	○	X	○	X	○	○	X	X	X	X	X	X	X	X

• Kanji Control Commands (DBCS Settings, Kanji Specifications Only)

Commands	Model Name													
	TSP700	TSP600	TSP800	TUP900	TSP1000	TSP700II	TSP650	TUP500	TSP800II	FVP10	BSC10	TSP043	TSP650II	TSP650IIISK
FS !	○	X	○	X	○	○	X	X	X	X	X	X	X	X
FS &	Spec. A	X	Spec. A	X	Spec. A	Spec. A	X	X	X	X	X	X	X	X
FS -	○	X	○	X	○	○	X	X	X	X	X	X	X	X
FS .	○	X	○	X	○	○	X	X	X	X	X	X	X	X
FS 2	○	X	○	X	○	○	X	X	X	X	X	X	X	X
FS C	○	X	○	X	○	○	X	X	X	X	X	X	X	X
FS S	○	X	○	X	○	○	X	X	X	X	X	X	X	X
FS W	○	X	○	X	○	○	X	X	X	X	X	X	X	X

## • ESC/POS Black Mark Related Commands (When black marks are effective)

Commands	Model Name														
	TSP700	TSP600	TSP800	TUP900	TSP1000	TSP700II	TSP650	TUP500	TSP800II	FVP10	BSC10	TSP043	TSP650II	TSP650II SK	
FF	○	X	○	X	○	○	X	X	X	X	X	X	X	X	
DLE ENQ	○	X	○	X	○	○	X	X	X	X	X	X	X	X	
GS FF	X	X	X	X	○	○	X	X	X	X	X	X	X	X	
GS ( F	X	X	X	X	○	X	X	X	X	X	X	X	X	X	
GS ( M n=1	X	X	X	X	○	X	X	X	X	X	X	X	X	X	
GS ( M n=2	X	X	X	X	○	X	X	X	X	X	X	X	X	X	
GS ( M n=3	X	X	X	X	○	X	X	X	X	X	X	X	X	X	
GS <	○	X	○	X	X	○	X	X	X	X	X	X	X	X	
GS V	○	X	○	X	○	○	X	X	X	X	X	X	X	X	

## • STAR Original Commands

Commands	Model Name														
	TSP700	TSP600	TSP800	TUP900	TSP1000	TSP700II	TSP650	TUP500	TSP800II	FVP10	BSC10	TSP043	TSP650II	TSP650II SK	
ESC GS =	○	X	○	X	○	○	X	X	X	X	X	X	X	X	
ESC GS t	Spec. A	X	Spec. A	X	Spec. A	Spec. A	X	X	X	X	X	X	X	X	
ESC GS +	X	X	X	X	X	○	X	X	X	X	X	X	X	X	
ESCGS#m	Spec. B	X	Spec. B	X	Spec. B	Spec. B	X	X	X	X	X	X	X	X	
ESCRSF	X	X	X	X	○	○	X	X	X	X	X	X	X	X	
ESCRSC	X	X	X	X	X	○	X	X	X	X	X	X	X	X	
ESCRSL	X	X	X	X	X	Spec. A Ver. 1.3~ 1.4  Spec. B Ver. 2.0 or later	X	X	X	X	X	X	X	X	
ESCGSETX	X	X	X	X	X	Spec. A Ver. 2.0 or later  Spec. B Ver. 3.0 or later	X	X	X	X	X	X	X	X	

## • STAR Original Presenter Control Commands

Commands	Model Name													
	TSP700	TSP600	TSP800	TUP900	TSP1000	TSP700II	TSP650	TUP500	TSP800II	FVP10	BSC10	TSP043	TSP650II	TSP650IIISK
ESC SYN 0	X	X	X	X	X	X	X	X	X	X	X	X	X	X
ESC SYN 1	X	X	X	X	X	X	X	X	X	X	X	X	X	X
ESC SYN 3	X	X	X	X	X	X	X	X	X	X	X	X	X	X
ESC SYN 4	X	X	X	X	X	X	X	X	X	X	X	X	X	X
ESC GS SUB DC1	X	X	X	X	X	X	X	X	X	X	X	X	X	X
ESC GS SUB DC2	X	X	X	X	X	X	X	X	X	X	X	X	X	X
ESC GS SUB DC3	X	X	X	X	X	X	X	X	X	X	X	X	X	X

## • Star Original Mark Commands

Commands	Model Name													
	TSP700	TSP600	TSP800	TUP900	TSP1000	TSP700II	TSP650	TUP500	TSP800II	FVP10	BSC10	TSP043	TSP650II	TSP650IIISK
ESC GS * 0	Ver4.0 or later	X	X	X	○	○	X	X	X	X	X	X	X	X
ESC GS * 1	Ver4.0 or later	X	X	X	○	○	X	X	X	X	X	X	X	X
ESC GS * 2	Ver4.0 or later	X	X	X	○	○	X	X	X	X	X	X	X	X
ESCGS * W	Ver4.0 or later	X	X	X	○	○	X	X	X	X	X	X	X	X
ESC GS * C	Ver4.0 or later	X	X	X	○	○	X	X	X	X	X	X	X	X

## • STAR Original Auto Logo Commands

Commands	Model Name													
	TSP700	TSP600	TSP800	TUP900	TSP1000	TSP700II	TSP650	TUP500	TSP800II	FVP10	BSC10	TSP043	TSP650II	TSP650IIISK
ESCGS / W	Ver4.0 or later	X	X	X	X	○	X	X	X	X	X	X	X	X
ESC GS / C	Ver4.0 or later	X	X	X	X	○	X	X	X	X	X	X	X	X
ESC GS / 1	Ver4.0 or later	X	X	X	X	○	X	X	X	X	X	X	X	X
ESC GS / 2	Ver4.0 or later	X	X	X	X	○	X	X	X	X	X	X	X	X
ESC GS / 3	Ver4.0 or later	X	X	X	X	○	X	X	X	X	X	X	X	X
ESC GS / 4	Ver4.0 or later	X	X	X	X	○	X	X	X	X	X	X	X	X
ESC GS / 5	Ver4.0 or later	X	X	X	X	○	X	X	X	X	X	X	X	X
ESC GS / 6	Ver4.0 or later	X	X	X	X	○	X	X	X	X	X	X	X	X

## • Star Original Buzzer Commands

Commands	Model Name														
	TSP700	TSP600	TSP800	TUP900	TSP1000	TSP700II	TSP650	TUP500	TSP800II	FVP10	BSC10	TSP043	TSP650II	TSP650II SK	
ESC GS BEL	Ver5.0 or later	X	X	X	○	○	X	X	X	X	X	X	X	X	
ESC GS EM DC1	X	X	X	X	X	Ver1.3 or later	X	X	X	X	X	X	X	X	
ESC GS EM DC2	X	X	X	X	X	Ver1.3 or later	X	X	X	X	X	X	X	X	

## • Star Original PDF417 Commands

Commands	Model Name														
	TSP700	TSP600	TSP800	TUP900	TSP1000	TSP700II	TSP650	TUP500	TSP800II	FVP10	BSC10	TSP043	TSP650II	TSP650II SK	
ESC GS x S 0	X	X	X	X	○	○	X	X	X	X	X	X	X	X	
ESC GS x S 1	X	X	X	X	○	○	X	X	X	X	X	X	X	X	
ESC GS x S 2	X	X	X	X	○	○	X	X	X	X	X	X	X	X	
ESC GS x S 3	X	X	X	X	○	○	X	X	X	X	X	X	X	X	
ESC GS x D	X	X	X	X	○	○	X	X	X	X	X	X	X	X	
ESC GS x P	X	X	X	X	○	○	X	X	X	X	X	X	X	X	
ESC GS x I	X	X	X	X	○	○ Ver 5.1 or older x Ver 6.0 or later	X	X	X	X	X	X	X	X	

## • Star Original Print Starting Trigger Control Commands

Commands	Model Name														
	TSP700	TSP600	TSP800	TUP900	TSP1000	TSP700II	TSP650	TUP500	TSP800II	FVP10	BSC10	TSP043	TSP650II	TSP650II SK	
ESC GS g 0	X	X	X	X	Ver1.1 or later	○	X	X	X	X	X	X	X	X	
ESC GS g 1	X	X	X	X	Ver1.1 or later	○	X	X	X	X	X	X	X	X	

## • Star Original QR Commands

Commands	Model Name														
	TSP700	TSP600	TSP800	TUP900	TSP1000	TSP700II	TSP650	TUP800	TSP800II	FVP10	BSC10	TSP043	TSP650II	TSP650II SK	
ESC GS y S 0	X	X	X	X	Ver1.2 or later	○	X	X	X	X	X	X	X	X	
ESC GS y S 1	X	X	X	X	Ver1.2 or later	○	X	X	X	X	X	X	X	X	
ESC GS y S 2	X	X	X	X	Ver1.2 or later	○	X	X	X	X	X	X	X	X	
ESC GS y D 1	X	X	X	X	Ver1.2 or later	○	X	X	X	X	X	X	X	X	
ESC GS y D 2	X	X	X	X	Ver1.2 or later	○	X	X	X	X	X	X	X	X	
ESC GS y P	X	X	X	X	Ver1.2 or later	○	X	X	X	X	X	X	X	X	
ESC GS y I	X	X	X	X	Ver 1.2 or later	○ Ver 5.1 or older x Ver 6.0 or later	X	X	X	X	X	X	X	X	

## • Star Original Page Function Commands

Commands	Model Name													
	TSP700	TSP600	TSP800	TUP900	TSP1000	TSP700II	TSP650	TUP500	TSP800II	FVP10	BSC10	TSP043	TSP650II	TSP650IIISK
ESC GS h 0	X	X	X	X	X	○	X	X	X	X	X	X	X	X
ESC GS h 1	X	X	X	X	X	○	X	X	X	X	X	X	X	X

## • Star Original Reduced Printing Function Command

Commands	Model Name													
	TSP700	TSP600	TSP800	TUP900	TSP1000	TSP700II	TSP650	TUP500	TSP800II	FVP10	BSC10	TSP043	TSP650II	TSP650IIISK
ESC GS c	X	X	X	X	X	X	X	X	X	X	X	X	X	X

## • Star Original Text Search Commands

Commands	Model Name													
	TSP700	TSP600	TSP800	TUP900	TSP1000	TSP700II	TSP650	TUP500	TSP800II	FVP10	BSC10	TSP043	TSP650II	TSP650IIISK
ESC GS ) B (fn = 48)	X	X	X	X	X	X	X	X	X	X	X	X	X	X
ESC GS ) B (fn = 49)	X	X	X	X	X	X	X	X	X	X	X	X	X	X
ESC GS ) B (fn = 50)	X	X	X	X	X	X	X	X	X	X	X	X	X	X
ESC GS ) B (fn = 64)	X	X	X	X	X	X	X	X	X	X	X	X	X	X
ESC GS ) B (fn = 65)	X	X	X	X	X	X	X	X	X	X	X	X	X	X
ESC GS ) B (fn = 66)	X	X	X	X	X	X	X	X	X	X	X	X	X	X
ESC GS ) B (fn = 80)	X	X	X	X	X	X	X	X	X	X	X	X	X	X
ESC GS ) B (fn = 81)	X	X	X	X	X	X	X	X	X	X	X	X	X	X
ESC GS ) B (fn = 96)	X	X	X	X	X	X	X	X	X	X	X	X	X	X
ESC GS ) B (fn = 97)	X	X	X	X	X	X	X	X	X	X	X	X	X	X

## • Star Original Printer Information Transmission Command

Commands	Model Name													
	TSP700	TSP600	TSP800	TUP900	TSP1000	TSP700II	TSP650	TUP500	TSP800II	FVP10	BSC10	TSP043	TSP650II	TSP650IIISK
ESC GS ) I (fn = 48)	X	X	X	X	X	X	X	X	X	X	X	X	X	X

## • Star Original Individual Logo Command

Commands	Model Name													
	TSP700	TSP600	TSP800	TUP900	TSP1000	TSP700II	TSP650	TUP500	TSP800II	FVP10	BSC10	TSP043	TSP650II	TSP650IIISK
ESC GS ) L (fn = 48)	X	X	X	X	X	X	X	X	X	X	X	X	X	X
ESC GS ) L (fn = 49)	X	X	X	X	X	X	X	X	X	X	X	X	X	X
ESC GS ) L (fn = 50)	X	X	X	X	X	X	X	X	X	X	X	X	X	X

## • Star Original Audio Commands

Commands	Model Name													
	TSP700	TSP600	TSP800	TUP900	TSP1000	TSP700II	TSP650	TUP500	TSP800II	FVP10	BSC10	TSP043	TSP650II	TSP650IIISK
ESC GS s O	X	X	X	X	X	X	X	X	X	X	X	X	X	X
ESC GS s P	X	X	X	X	X	X	X	X	X	X	X	X	X	X
ESC GS s R	X	X	X	X	X	X	X	X	X	X	X	X	X	X
ESC GS s I	X	X	X	X	X	X	X	X	X	X	X	X	X	X
ESC GS s U	X	X	X	X	X	X	X	X	X	X	X	X	X	X
ESC GS s T	X	X	X	X	X	X	X	X	X	X	X	X	X	X

## • Star Original Hold print control Command

Commands	Model Name													
	TSP700	TSP600	TSP800	TUP900	TSP1000	TSP700II	TSP650	TUP500	TSP800II	FVP10	BSC10	TSP043	TSP650II	TSP650IIISK
ESC SYN DC3	X	X	X	X	X	X	X	X	X	X	X	X	X	X
ESC SYN DC4	X	X	X	X	X	X	X	X	X	X	X	X	X	X
ESC GS )s	X	X	X	X	X	X	X	X	X	X	X	X	X	X

**7-8 Bluetooth I/F**

## • Standard Commands

Commands	Model Name													
	TSP700	TSP600	TSP800	TUP900	TSP1000	TSP700II	TSP650	TUP500	TSP800II	FVP10	BSC10	TSP043	TSP650II	TSP650IIISK
HT	x	x	x	x	x	Ver5.0 or later	x	x	Ver2.0 or later	Ver2.0 or later	x	x	o	o
LF	x	x	x	x	x	Ver5.0 or later	x	x	Ver2.0 or later	Ver2.0 or later	x	x	o	o
FF	x	x	x	x	x	Ver5.0 or later	x	x	Ver2.0 or later	Ver2.0 or later	x	x	o	o
CR	x	x	x	x	x	Ver5.0 or later	x	x	Ver2.0 or later	x	x	x	o	o
CAN	x	x	x	x	x	Ver5.0 or later	x	x	Ver2.0 or later	Ver2.0 or later	x	x	o	o
DLE EOT	x	x	x	x	x	Spec. B-2 Ver5.0 or later	x	x	Spec. B-2 Ver2.0 or later	Spec. B-2 Ver2.0 or later	x	x	Spec.B-2	Spec.B-2
DLE ENQ	x	x	x	x	x	x	x	x	x	x	x	x	x	x
DLE DC4	x	x	x	x	x	Ver5.0 or later	x	x	Ver2.0 or later	Ver2.0 or later	x	x	o	o
ESC FF	x	x	x	x	x	Ver5.0 or later	x	x	Ver2.0 or later	Ver2.0 or later	x	x	o	o
ESC SP	x	x	x	x	x	Ver5.0 or later	x	x	Ver2.0 or later	Ver2.0 or later	x	x	o	o
ESC !	x	x	x	x	x	Ver5.0 or later	x	x	Ver2.0 or later	Ver2.0 or later	x	x	o	o
ESC \$	x	x	x	x	x	Ver5.0 or later	x	x	Ver2.0 or later	Ver2.0 or later	x	x	o	o
ESC %	x	x	x	x	x	Ver5.0 or later	x	x	Ver2.0 or later	Ver2.0 or later	x	x	o	o
ESC &	x	x	x	x	x	Ver5.0 or later	x	x	Ver2.0 or later	Ver2.0 or later	x	x	o	o
ESC *	x	x	x	x	x	Spec.A Ver5.0 or later	x	x	Spec.A Ver2.0 or later	Spec.A Ver2.0 or later	x	x	Spec.B	Spec.B
ESC -	x	x	x	x	x	Ver5.0 or later	x	x	Ver2.0 or later	Ver2.0 or later	x	x	o	o
ESC 2	x	x	x	x	x	Ver5.0 or later	x	x	Ver2.0 or later	Ver2.0 or later	x	x	o	o
ESC 3	x	x	x	x	x	Ver5.0 or later	x	x	Ver2.0 or later	Ver2.0 or later	x	x	o	o
ESC =	x	x	x	x	x	Ver5.0 or later	x	x	Ver2.0 or later	Ver2.0 or later	x	x	o	o
ESC ?	x	x	x	x	x	Ver5.0 or later	x	x	Ver2.0 or later	Ver2.0 or later	x	x	o	o
ESC @	x	x	x	x	x	Ver5.0 or later	x	x	Ver2.0 or later	Ver2.0 or later	x	x	o	o
ESC D	x	x	x	x	x	Ver5.0 or later	x	x	Ver2.0 or later	Ver2.0 or later	x	x	o	o
ESC E	x	x	x	x	x	Ver5.0 or later	x	x	Ver2.0 or later	Ver2.0 or later	x	x	o	o
ESC G	x	x	x	x	x	Ver5.0 or later	x	x	Ver2.0 or later	Ver2.0 or later	x	x	o	o
ESC J	x	x	x	x	x	Ver5.0 or later	x	x	Ver2.0 or later	Ver2.0 or later	x	x	o	o
ESC L	x	x	x	x	x	Ver5.0 or later	x	x	Ver2.0 or later	Ver2.0 or later	x	x	o	o
ESC M	x	x	x	x	x	Ver5.0 or later	x	x	Ver2.0 or later	Ver2.0 or later	x	x	o	o
ESC R	x	x	x	x	x	Spec.A Ver5.0 or later	x	x	Spec.A Ver2.0 or later	Spec.A Ver2.0 or later	x	x	Spec.B	Spec.B



Commands	Model Name													
	TSP700	TSP600	TSP800	TUP900	TSP1000	TSP700II	TSP650	TUP500	TSP800II	FVP10	BSC10	TSP043	TSP650II	TSP650IIISK
ESC S	x	x	x	x	x	Ver5.0 or later	x	x	Ver2.0 or later	Ver2.0 or later	x	x	o	o
ESC T	x	x	x	x	x	Ver5.0 or later	x	x	Ver2.0 or later	Ver2.0 or later	x	x	o	o
ESC V	x	x	x	x	x	Ver5.0 or later	x	x	Ver2.0 or later	Ver2.0 or later	x	x	o	o
ESC W	x	x	x	x	x	Ver5.0 or later	x	x	Ver2.0 or later	Ver2.0 or later	x	x	o	o
ESC \	x	x	x	x	x	Ver5.0 or later	x	x	Ver2.0 or later	Ver2.0 or later	x	x	o	o
ESC a	x	x	x	x	x	Ver5.0 or later	x	x	Ver2.0 or later	Ver2.0 or later	x	x	o	o
ESC c 3	x	x	x	x	x	Spec.B-α Ver5.0 or later	x	x	Spec.B-α Ver2.0 or later	x	x	x	Spec.B-α	Spec.B-α
ESC c 4	x	x	x	x	x	Ver5.0 or later	x	x	Ver2.0 or later	Ver2.0 or later	x	x	o	o
ESC c 5	x	x	x	x	x	Ver5.0 or later	x	x	Ver2.0 or later	Ver2.0 or later	x	x	o	o
ESC d	x	x	x	x	x	Ver5.0 or later	x	x	Ver2.0 or later	Ver2.0 or later	x	x	o	o
ESC p	x	x	x	x	x	Ver5.0 or later	x	x	Ver2.0 or later	Ver2.0 or later	x	x	o	o
ESC t	x	x	x	x	x	Spec.A Ver5.0 or later	x	x	Spec.A Ver2.0 or later	Spec.A Ver2.0 or later	x	x	Spec.B	Spec.B
ESC {	x	x	x	x	x	Ver5.0 or later	x	x	Ver2.0 or later	Ver2.0 or later	x	x	o	o
FS g 1	x	x	x	x	x	x	x	x	x	x	x	x	x	x
FS g 2	x	x	x	x	x	x	x	x	x	x	x	x	x	x
FS p	x	x	x	x	x	Ver5.0 or later	x	x	Ver2.0 or later	Ver2.0 or later	x	x	o	o
FS q	x	x	x	x	x	Ver5.0 or later	x	x	Ver2.0 or later	Ver2.0 or later	x	x	o	o
GS !	x	x	x	x	x	Ver5.0 or later	x	x	Ver2.0 or later	Ver2.0 or later	x	x	o	o
GS \$	x	x	x	x	x	Ver5.0 or later	x	x	Ver2.0 or later	Ver2.0 or later	x	x	o	o
GS *	x	x	x	x	x	Ver5.0 or later	x	x	Ver2.0 or later	Ver2.0 or later	x	x	o	o
GS ( A	x	x	x	x	x	Ver5.0 or later	x	x	Ver2.0 or later	Ver2.0 or later	x	x	o	o
GS ( K (fn=49)	x	x	x	x	x	Spec.A	x	x	Spec.B Ver2.0 or later	Spec.B Ver2.0 or later	x	x	Spec.C	x
GS ( K (fn=50)	x	x	x	x	x	x	x	x	x	x	x	x	Spec.A	Spec.B
GS ( L (fn=48)	x	x	x	x	x	x	x	x	x	x	x	x	o	o
GS ( L (fn=51)	x	x	x	x	x	x	x	x	x	x	x	x	o	o
GS ( L (fn=64)	x	x	x	x	x	x	x	x	x	x	x	x	o	o
GS ( L (fn=65)	x	x	x	x	x	x	x	x	x	x	x	x	o	o
GS ( L (fn=66)	x	x	x	x	x	x	x	x	x	x	x	x	o	o
GS ( L (fn=67)	x	x	x	x	x	x	x	x	x	x	x	x	o	o
GS ( L (fn=69)	x	x	x	x	x	x	x	x	x	x	x	x	o	o
GS ( L (fn=112)	x	x	x	x	x	x	x	x	Ver2.0 or later	Ver2.0 or later	x	x	o	o
GS 8 L (fn=48)	x	x	x	x	x	x	x	x	x	x	x	x	o	o
GS 8 L (fn=51)	x	x	x	x	x	x	x	x	x	x	x	x	o	o
GS 8 L (fn=64)	x	x	x	x	x	x	x	x	x	x	x	x	o	o
GS 8 L (fn=65)	x	x	x	x	x	x	x	x	x	x	x	x	o	o
GS 8 L (fn=66)	x	x	x	x	x	x	x	x	x	x	x	x	o	o
GS 8 L (fn=67)	x	x	x	x	x	x	x	x	x	x	x	x	o	o
GS 8 L (fn=69)	x	x	x	x	x	x	x	x	x	x	x	x	o	o
GS 8 L (fn=112)	x	x	x	x	x	x	x	x	Ver2.0 or later	Ver2.0 or later	x	x	o	o

Commands	Model Name													
	TSP700	TSP600	TSP800	TUP900	TSP1000	TSP700II	TSP650	TUP500	TSP800II	FVP10	BSC10	TSP043	TSP650II	TSP650IISK
GS ( N	x	x	x	x	x	Ver5.0 or later	x	x	Ver2.0 or later	Ver2.0 or later	x	x	o	x
GS ( k (cn=48,fn=65)	x	x	x	x	x	x	x	x	x	x	x	x	o	o
GS ( k (cn=48,fn=66)	x	x	x	x	x	x	x	x	x	x	x	x	o	o
GS ( k (cn=48,fn=67)	x	x	x	x	x	x	x	x	x	x	x	x	o	o
GS ( k (cn=48,fn=68)	x	x	x	x	x	x	x	x	x	x	x	x	o	o
GS ( k (cn=48,fn=69)	x	x	x	x	x	x	x	x	x	x	x	x	o	o
GS ( k (cn=48,fn=70)	x	x	x	x	x	x	x	x	x	x	x	x	o	o
GS ( k (cn=48,fn=80)	x	x	x	x	x	x	x	x	x	x	x	x	o	o
GS ( k (cn=48,fn=81)	x	x	x	x	x	x	x	x	x	x	x	x	o	o
GS ( k (cn=48,fn=82)	x	x	x	x	x	x	x	x	x	x	x	x	o Ver. 1.2 or older x Ver.2.0 or later	x
GS ( k (cn=49,fn=65)	x	x	x	x	x	x	x	x	x	x	x	x	o	o
GS ( k (cn=49,fn=67)	x	x	x	x	x	x	x	x	x	x	x	x	o	o
GS ( k (cn=49,fn=69)	x	x	x	x	x	x	x	x	x	x	x	x	o	o
GS ( k (cn=49,fn=80)	x	x	x	x	x	x	x	x	x	x	x	x	o	o
GS ( k (cn=49,fn=81)	x	x	x	x	x	x	x	x	x	x	x	x	o	o
GS ( k (cn=49,fn=82)	x	x	x	x	x	x	x	x	x	x	x	x	o Ver. 1.2 or older x Ver.2.0 or later	x
GS ( k (cn=51,fn=67)	x	x	x	x	x	x	x	x	x	x	x	x	Ver.2.0 or later	o
GS ( k (cn=51,fn=71)	x	x	x	x	x	x	x	x	x	x	x	x	Ver.2.0 or later	o
GS ( k (cn=51,fn=80)	x	x	x	x	x	x	x	x	x	x	x	x	Ver.2.0 or later	o
GS ( k (cn=51,fn=81)	x	x	x	x	x	x	x	x	x	x	x	x	Ver.2.0 or later	o
GS ( k (cn=52,fn=67)	x	x	x	x	x	x	x	x	x	x	x	x	Ver.2.0 or later	o
GS ( k (cn=52,fn=71)	x	x	x	x	x	x	x	x	x	x	x	x	Ver.2.0 or later	o
GS ( k (cn=52,fn=72)	x	x	x	x	x	x	x	x	x	x	x	x	Ver.2.0 or later	o
GS ( k (cn=52,fn=80)	x	x	x	x	x	x	x	x	x	x	x	x	Ver.2.0 or later	o
GS ( k (cn=52,fn=81)	x	x	x	x	x	x	x	x	x	x	x	x	Ver.2.0 or later	o
GS /	x	x	x	x	x	Ver5.0 or later	x	x	Ver2.0 or later	Ver2.0 or later	x	x	o	o
GS :	x	x	x	x	x	Ver5.0 or later	x	x	Ver2.0 or later	Ver2.0 or later	x	x	o	o
GS B	x	x	x	x	x	Ver5.0 or later	x	x	Ver2.0 or later	Ver2.0 or later	x	x	o	o
GS C 0	x	x	x	x	x	Ver5.0 or later	x	x	Ver2.0 or later	Ver2.0 or later	x	x	o	o
GS C 1	x	x	x	x	x	Ver5.0 or later	x	x	Ver2.0 or later	Ver2.0 or later	x	x	o	o
GS C 2	x	x	x	x	x	Ver5.0 or later	x	x	Ver2.0 or later	Ver2.0 or later	x	x	o	o
GS C ;	x	x	x	x	x	Ver5.0 or later	x	x	Ver2.0 or later	Ver2.0 or later	x	x	o	o
GS E	x	x	x	x	x	Spec. A Ver5.0 or later	x	x	Spec. A Ver2.0 or later	Spec. A Ver2.0 or later	x	x	Spec. A	Spec. B
GS H	x	x	x	x	x	Ver5.0 or later	x	x	Ver2.0 or later	Ver2.0 or later	x	x	o	o

Commands	Model Name													
	TSP700	TSP600	TSP800	TUP900	TSP1000	TSP700II	TSP650	TUP500	TSP800II	FVP10	BSC10	TSP043	TSP650II	TSP650IIISK
GS I	x	x	x	x	x	Spec.B Ver5.0 or later	x	x	Spec.A Ver2.0 or later	Spec.B Ver2.0 or later	x	x	Spec.B	Spec.B
GS L	x	x	x	x	x	Ver5.0 or later	x	x	Ver2.0 or later	Ver2.0 or later	x	x	o	o
GS P	x	x	x	x	x	Ver5.0 or later	x	x	Ver2.0 or later	Ver2.0 or later	x	x	o	o
GS T	x	x	x	x	x	Ver5.0 or later	x	x	Ver2.0 or later	Ver2.0 or later	x	x	o	o
GS V	x	x	x	x	x	Ver5.0 or later	x	x	Ver2.0 or later	Ver2.0 or later	x	x	o	o
GS W	x	x	x	x	x	Ver5.0 or later	x	x	Ver2.0 or later	Ver2.0 or later	x	x	o	o
GS \	x	x	x	x	x	Ver5.0 or later	x	x	Ver2.0 or later	Ver2.0 or later	x	x	o	o
GS ^	x	x	x	x	x	Ver5.0 or later	x	x	Ver2.0 or later	Ver2.0 or later	x	x	o	o
GS b	x	x	x	x	x	x	x	x	x	x	x	x	o	o
GS c	x	x	x	x	x	Ver5.0 or later	x	x	Ver2.0 or later	Ver2.0 or later	x	x	o	o
GS f	x	x	x	x	x	Ver5.0 or later	x	x	Ver2.0 or later	Ver2.0 or later	x	x	o	o
GS h	x	x	x	x	x	Ver5.0 or later	x	x	Ver2.0 or later	Ver2.0 or later	x	x	o	o
GS k	x	x	x	x	x	Spec.A,B: Ver5.0 or later	x	x	Spec.A,B: Ver2.0 or later	Spec.A,B: Ver2.0 or later	x	x	Spec. A,B: Ver. 1.2 or older  Spec. A,B,C: Ver.2.0 or later	Spec. A,B,C
GS r	x	x	x	x	x	Ver5.0 or later	x	x	Ver2.0 or later	Ver2.0 or later	x	x	o	o
GS v 0	x	x	x	x	x	Ver5.0 or later	x	x	Ver2.0 or later	Ver2.0 or later	x	x	o	o
GS w	x	x	x	x	x	Ver5.0 or later	x	x	Ver2.0 or later	Ver2.0 or later	x	x	o	o

• Kanji Control Commands (DBCS Settings, Kanji Specifications Only)

Commands	Model Name													
	TSP700	TSP600	TSP800	TUP900	TSP1000	TSP700II	TSP650	TUP500	TSP800II	FVP10	BSC10	TSP043	TSP650II	TSP650IIISK
FS !	x	x	x	x	x	Ver5.0 or later	x	x	Ver2.0 or later	Ver2.0 or later	x	x	o	o
FS &	x	x	x	x	x	Spec.A: Ver5.0 or later	x	x	Spec.A: Ver2.0 or later	Spec.A: Ver2.0 or later	x	x	Spec.A	Spec.A
FS -	x	x	x	x	x	Ver5.0 or later	x	x	Ver2.0 or later	Ver2.0 or later	x	x	o	o
FS .	x	x	x	x	x	Ver5.0 or later	x	x	Ver2.0 or later	Ver2.0 or later	x	x	o	o
FS 2	x	x	x	x	x	Ver5.0 or later	x	x	Ver2.0 or later	Ver2.0 or later	x	x	o	o
FS C	x	x	x	x	x	Ver5.0 or later	x	x	Ver2.0 or later	Ver2.0 or later	x	x	o	o
FS S	x	x	x	x	x	Ver5.0 or later	x	x	Ver2.0 or later	Ver2.0 or later	x	x	o	o
FS W	x	x	x	x	x	Ver5.0 or later	x	x	Ver2.0 or later	Ver2.0 or later	x	x	o	o

## • ESC/POS Black Mark Related Commands (When black marks are effective)

Commands	Model Name													
	TSP700	TSP600	TSP800	TUP900	TSP1000	TSP700II	TSP650	TUP500	TSP800II	FVP10	BSC10	TSP043	TSP650II	TSP650IIISK
FF	x	x	x	x	x	Ver5.0 or later	x	x	Ver2.0 or later	Ver2.0 or later	x	x	x	x
DLE ENQ	x	x	x	x	x	Ver5.0 or later	x	x	Ver2.0 or later	Ver2.0 or later	x	x	x	x
GS FF	x	x	x	x	x	Ver5.0 or later	x	x	Ver2.0 or later	Ver2.0 or later	x	x	x	x
GS ( F	x	x	x	x	x	x	x	x	x	x	x	x	x	x
GS ( M n=1	x	x	x	x	x	x	x	x	x	x	x	x	x	x
GS ( M n=2	x	x	x	x	x	x	x	x	x	x	x	x	x	x
GS ( M n=3	x	x	x	x	x	x	x	x	x	x	x	x	x	x
GS <	x	x	x	x	x	Ver5.0 or later	x	x	Ver2.0 or later	Ver2.0 or later	x	x	x	x
GS V	x	x	x	x	x	Ver5.0 or later	x	x	Ver2.0 or later	Ver2.0 or later	x	x	x	x

## • STAR Original Commands

Commands	Model Name													
	TSP700	TSP600	TSP800	TUP900	TSP1000	TSP700II	TSP650	TUP500	TSP800II	FVP10	BSC10	TSP043	TSP650II	TSP650IIISK
ESC GS =	x	x	x	x	x	Ver5.0 or later	x	x	Ver2.0 or later	Ver2.0 or later	x	x	o	o
ESC GS t	x	x	x	x	x	Spec.A: Ver5.0 or later	x	x	Spec.A: Ver2.0 or later	Spec.A: Ver2.0 or later	x	x	Spec.B	Spec.B
ESC GS +	x	x	x	x	x	Ver5.0 or later	x	x	Ver2.0 or later	Ver2.0 or later	x	x	o	o
ESCGS#m	x	x	x	x	x	Spec.C: Ver5.0 or later	x	x	Spec.C: Ver2.0 or later	Spec.C: Ver2.0 or later	x	x	Spec.C	Spec.C
ESCRSF	x	x	x	x	x	Ver5.0 or later	x	x	Ver2.0 or later	Ver2.0 or later	x	x	o	o
ESCRSC	x	x	x	x	x	Ver5.0 or later	x	x	Ver2.0 or later	Ver2.0 or later	x	x	o	x
ESCRSL	x	x	x	x	x	Spec.B: Ver5.0 or later	x	x	Spec.B: Ver2.0 or later	Spec.B: Ver2.0 or later	x	x	Spec.B	Spec.B
ESCGSETX	x	x	x	x	x	Spec.C: Ver5.0 or later	x	x	Spec.C: Ver2.0 or later	Spec.B: Ver.1.5 or older Spec.C: Ver2.0 or later	x	x	Spec. B: Ver. 1.2 or older Spec. C: Ver.2.0 or later	Spec.C

• STAR Original Presenter Control Commands

Commands	Model Name													
	TSP700	TSP600	TSP800	TUP900	TSP1000	TSP700II	TSP650	TUP500	TSP800II	FVP10	BSC10	TSP043	TSP650II	TSP650IISK
ESC SYN 0	x	x	x	x	x	x	x	x	x	x	x	x	x	x
ESC SYN 1	x	x	x	x	x	x	x	x	x	x	x	x	x	x
ESC SYN 3	x	x	x	x	x	x	x	x	x	x	x	x	x	x
ESC SYN 4	x	x	x	x	x	x	x	x	x	x	x	x	x	x
ESC GS SUB DC1	x	x	x	x	x	x	x	x	x	x	x	x	x	x
ESC GS SUB DC2	x	x	x	x	x	x	x	x	x	x	x	x	x	x
ESC GS SUB DC3	x	x	x	x	x	x	x	x	x	x	x	x	x	x

• Star Original Mark Commands

Commands	Model Name													
	TSP700	TSP600	TSP800	TUP900	TSP1000	TSP700II	TSP650	TUP500	TSP800II	FVP10	BSC10	TSP043	TSP650II	TSP650IISK
ESC GS * 0	X	X	X	X	X	Ver5.0 or later	X	X	Ver2.0 or later	Ver2.0 or later	X	X	o	o
ESC GS * 1	X	X	X	X	X	Ver5.0 or later	X	X	Ver2.0 or later	Ver2.0 or later	X	X	o	o
ESC GS * 2	X	X	X	X	X	Ver5.0 or later	X	X	Ver2.0 or later	Ver2.0 or later	X	X	o	o
ESCGS * W	X	X	X	X	X	Ver5.0 or later	X	X	Ver2.0 or later	Ver2.0 or later	X	X	o	o
ESC GS * C	X	X	X	X	X	Ver5.0 or later	X	X	Ver2.0 or later	Ver2.0 or later	X	X	o	o

• STAR Original Auto Logo Commands

Commands	Model Name													
	TSP700	TSP600	TSP800	TUP900	TSP1000	TSP700II	TSP650	TUP500	TSP800II	FVP10	BSC10	TSP043	TSP650II	TSP650IISK
ESCGS/W	x	x	x	x	x	Ver5.0 or later	x	x	Ver2.0 or later	Ver2.0 or later	x	x	o	o
ESC GS / C	x	x	x	x	x	Ver5.0 or later	x	x	Ver2.0 or later	Ver2.0 or later	x	x	o	o
ESC GS / 1	x	x	x	x	x	Ver5.0 or later	x	x	Ver2.0 or later	Ver2.0 or later	x	x	o	o
ESC GS / 2	x	x	x	x	x	Ver5.0 or later	x	x	Ver2.0 or later	Ver2.0 or later	x	x	o	o
ESC GS / 3	x	x	x	x	x	Ver5.0 or later	x	x	Ver2.0 or later	Ver2.0 or later	x	x	o	o
ESC GS / 4	x	x	x	x	x	Ver5.0 or later	x	x	Ver2.0 or later	Ver2.0 or later	x	x	o	o
ESC GS / 5	x	x	x	x	x	Ver5.0 or later	x	x	Ver2.0 or later	Ver2.0 or later	x	x	o	o
ESC GS / 6	x	x	x	x	x	Ver5.0 or later	x	x	Ver2.0 or later	Ver2.0 or later	x	x	o	o

## • Star Original Buzzer Commands

Commands	Model Name													
	TSP700	TSP600	TSP800	TUP900	TSP1000	TSP700II	TSP650	TUP500	TSP800II	FVP10	BSC10	TSP043	TSP650II	TSP650IIISK
ESC GS BEL	x	x	x	x	x	Ver5.0 or later	x	x	Ver2.0 or later	Ver2.0 or later	x	x	o	o
ESC GS EM DC1	x	x	x	x	x	Ver5.0 or later	x	x	Ver2.0 or later	Ver2.0 or later	x	x	o	o
ESC GS EM DC2	x	x	x	x	x	Ver5.0 or later	x	x	Ver2.0 or later	Ver2.0 or later	x	x	o	o

## • Star Original PDF417 Commands

Commands	Model Name													
	TSP700	TSP600	TSP800	TUP900	TSP1000	TSP700II	TSP650	TUP500	TSP800II	FVP10	BSC10	TSP043	TSP650II	TSP650IIISK
ESC GS x S 0	x	x	x	x	x	Ver5.0 or later	x	x	Ver2.0 or later	Ver2.0 or later	x	x	x	x
ESC GS x S 1	x	x	x	x	x	Ver5.0 or later	x	x	Ver2.0 or later	Ver2.0 or later	x	x	x	x
ESC GS x S 2	x	x	x	x	x	Ver5.0 or later	x	x	Ver2.0 or later	Ver2.0 or later	x	x	x	x
ESC GS x S 3	x	x	x	x	x	Ver5.0 or later	x	x	Ver2.0 or later	Ver2.0 or later	x	x	x	x
ESC GS x D	x	x	x	x	x	Ver5.0 or later	x	x	Ver2.0 or later	Ver2.0 or later	x	x	x	x
ESC GS x P	x	x	x	x	x	Ver5.0 or later	x	x	Ver2.0 or later	Ver2.0 or later	x	x	x	x
ESC GS x I	x	x	x	x	x	x Ver.4.1 or older o Ver5.0 or later x Ver.6.0 or later	x	x	x Ver.1.6 or older o Ver2.0 or later x Ver.6.0 or later	Ver2.0 or later	x	x	x	x

## • Star Original Print Starting Trigger Control Commands

Commands	Model Name													
	TSP700	TSP600	TSP800	TUP900	TSP1000	TSP700II	TSP650	TUP500	TSP800II	FVP10	BSC10	TSP043	TSP650II	TSP650IIISK
ESC GS g 0	x	x	x	x	x	Ver5.0 or later	x	x	Ver2.0 or later	Ver2.0 or later	x	x	o	o
ESC GS g 1	x	x	x	x	x	Ver5.0 or later	x	x	Ver2.0 or later	Ver2.0 or later	x	x	o	o

## • Star Original QR Commands

Commands	Model Name													
	TSP700	TSP600	TSP800	TUP900	TSP1000	TSP700II	TSP650	TUP800	TSP800II	FVP10	BSC10	TSP043	TSP650II	TSP650IIISK
ESC GS y S 0	x	x	x	x	x	Ver5.0 or later	x	x	Ver2.0 or later	Ver2.0 or later	x	x	x	x
ESC GS y S 1	x	x	x	x	x	Ver5.0 or later	x	x	Ver2.0 or later	Ver2.0 or later	x	x	x	x
ESC GS y S 2	x	x	x	x	x	Ver5.0 or later	x	x	Ver2.0 or later	Ver2.0 or later	x	x	x	x
ESC GS y D 1	x	x	x	x	x	Ver5.0 or later	x	x	Ver2.0 or later	Ver2.0 or later	x	x	x	x
ESC GS y D 2	x	x	x	x	x	Ver5.0 or later	x	x	Ver2.0 or later	Ver2.0 or later	x	x	x	x
ESC GS y P	x	x	x	x	x	Ver5.0 or later	x	x	Ver2.0 or later	Ver2.0 or later	x	x	x	x
ESC GS y I	x	x	x	x	x	x Ver.4.1 or older o Ver5.0 or later x Ver.6.0 or later	x	x	x Ver.1.6 or older o Ver2.0 or later x Ver.6.0 or later	Ver2.0 or later	x	x	x	x

## • Star Original Page Function Commands

Commands	Model Name													
	TSP700	TSP600	TSP800	TUP900	TSP1000	TSP700II	TSP650	TUP500	TSP800II	FVP10	BSC10	TSP043	TSP650II	TSP650IIISK
ESC GS h 0	x	x	x	x	x	Ver5.0 or later	x	x	Ver2.0 or later	Ver2.0 or later	x	x	o	o
ESC GS h 1	x	x	x	x	x	Ver5.0 or later	x	x	Ver2.0 or later	Ver2.0 or later	x	x	o	o

## • Star Original Reduced Printing Function Command

Commands	Model Name													
	TSP700	TSP600	TSP800	TUP900	TSP1000	TSP700II	TSP650	TUP500	TSP800II	FVP10	BSC10	TSP043	TSP650II	TSP650IIISK
ESC GS c	x	x	x	x	x	x	x	x	x	Ver2.0 or later	x	x	o	x

## • Star Original Text Search Commands

Commands	Model Name													
	TSP700	TSP600	TSP800	TUP900	TSP1000	TSP700II	TSP650	TUP500	TSP800II	FVP10	BSC10	TSP043	TSP650II	TSP650IIISK
ESC GS ) B (fn=48)	x	x	x	x	x	x	x	x	x	Ver2.0 or later	x	x	o	o
ESC GS ) B (fn=49)	x	x	x	x	x	x	x	x	x	Ver2.0 or later	x	x	o	o
ESC GS ) B (fn=50)	x	x	x	x	x	x	x	x	x	Ver2.0 or later	x	x	o	o
ESC GS ) B (fn=64)	x	x	x	x	x	x	x	x	x	Ver2.0 or later	x	x	o	o
ESC GS ) B (fn=65)	x	x	x	x	x	x	x	x	x	Ver2.0 or later	x	x	o	o
ESC GS ) B (fn=66)	x	x	x	x	x	x	x	x	x	x	x	x	o	o
ESC GS ) B (fn=80)	x	x	x	x	x	x	x	x	x	Ver2.0 or later	x	x	o	o
ESC GS ) B (fn=81)	x	x	x	x	x	x	x	x	x	Ver2.0 or later	x	x	o	o
ESC GS ) B (fn=96)	x	x	x	x	x	x	x	x	x	Ver2.0 or later	x	x	o	o
ESC GS ) B (fn=97)	x	x	x	x	x	x	x	x	x	Ver2.0 or later	x	x	o	o

## • Star Original Printer Information Transmission Command

Commands	Model Name													
	TSP700	TSP600	TSP800	TUP900	TSP1000	TSP700II	TSP650	TUP500	TSP800II	FVP10	BSC10	TSP043	TSP650II	TSP650IIISK
ESC GS ) I (fn=48)	x	x	x	x	x	x	x	x	x	x	x	x	o	o

## • Star Original Individual Logo Command

Commands	Model Name													
	TSP700	TSP600	TSP800	TUP900	TSP1000	TSP700II	TSP650	TUP500	TSP800II	FVP10	BSC10	TSP043	TSP650II	TSP650IIISK
ESC GS ) L (fn=48)	x	x	x	x	x	x	x	x	x	x	x	x	o	o
ESC GS ) L (fn=49)	x	x	x	x	x	x	x	x	x	x	x	x	o	o
ESC GS ) L (fn=50)	x	x	x	x	x	x	x	x	x	x	x	x	Spec.B	Spec.C

## • Star Original Audio Commands

Commands	Model Name													
	TSP700	TSP600	TSP800	TUP900	TSP1000	TSP700II	TSP650	TUP500	TSP800II	FVP10	BSC10	TSP043	TSP650II	TSP650II SK
ESC GS s O	x	x	x	x	x	x	x	x	x	o	x	x	x	x
ESC GS s P	x	x	x	x	x	x	x	x	x	o	x	x	x	x
ESC GS s R	x	x	x	x	x	x	x	x	x	o	x	x	x	x
ESC GS s I	x	x	x	x	x	x	x	x	x	o	x	x	x	x
ESC GS s U	x	x	x	x	x	x	x	x	x	o	x	x	x	x
ESC GS s T	x	x	x	x	x	x	x	x	x	o	x	x	x	x

## • Star Original Hold print control Command

Commands	Model Name													
	TSP700	TSP600	TSP800	TUP900	TSP1000	TSP700II	TSP650	TUP500	TSP800II	FVP10	BSC10	TSP043	TSP650II	TSP650II SK
ESC SYN DC3	x	x	x	x	x	x	x	x	x	x	x	x	x	o
ESC SYN DC4	x	x	x	x	x	x	x	x	x	x	x	x	x	o
ESC GS ) s	x	x	x	x	x	x	x	x	x	x	x	x	x	o





*URL: <https://www.starmicronics.com/support/>*